

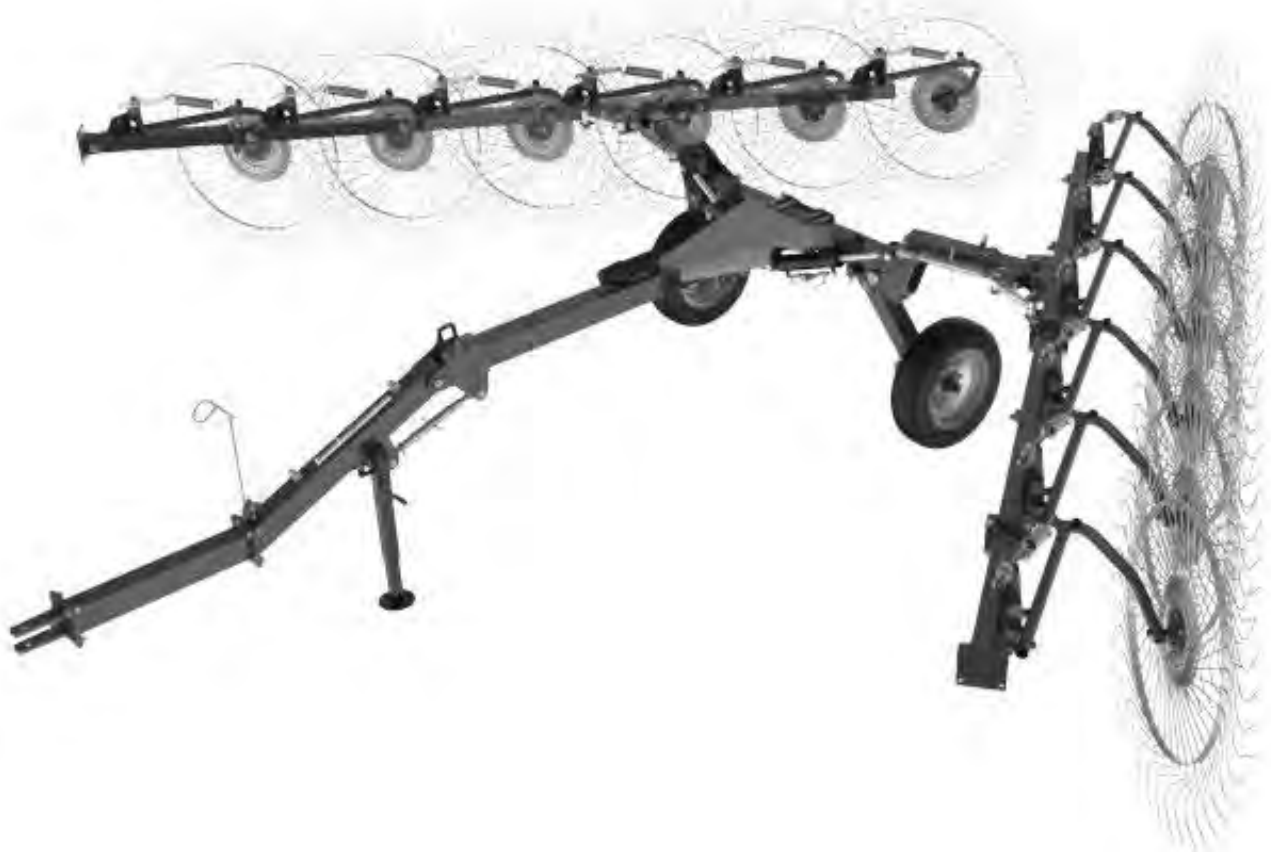

Power Rake

PR 8, PR 10, PR 12



Operator's Manual

Issue 1 (05/12/2025)

Page left blank intentionally



TO THE DEALER:

Assembly and proper installation of this product is the responsibility of the Tar River dealer. Read manual instructions and safety rules. Make sure all items on the Dealer's Pre-Delivery and Delivery Check Lists in the Owner's/Operator's Manual are completed before releasing equipment to the owner.

TO THE OWNER:

Read this manual before operating your Tar River equipment. The information presented will prepare you to do a better and safer job. Keep this manual handy for ready reference. Require all operators to read this manual carefully and become acquainted with all the adjustment and operating procedures before attempting to operate. Replacement manuals can be obtained from your selling dealer. The equipment you have purchased has been carefully engineered and manufactured to provide dependable and satisfactory use. Like all mechanical products, it will require cleaning and upkeep. Lubricate the unit as specified. Observe all safety information in this manual and safety decals on the equipment. For service, your authorized Tar River dealer has trained mechanics, genuine Tar River service parts, and the necessary tools and equipment to handle all your needs. Use only genuine Tar River service parts. Substitute parts will void the warranty and may not meet standards required for safe and satisfactory operation.

Record your implement model and serial number in the space provide below. Your dealer will need this information to give you prompt, efficient service.

Model Number: _____

Serial Number: _____

Date Purchased: _____

TO THE DEALER: Part 1 of 2

Assembly and proper installation of this product is the responsibility of the Belco Resources Dealer. Read manual instructions and safety rules. Make sure all items on the Dealer's Pre-Delivery List and Owners Check List in the Owner's/Operator's Manual are completed before releasing equipment to the owner.



NOTE: The machine must be inspected thoroughly by the dealer prior to delivery of machine to owner. Place a check mark in the box beside each item checked. Contact Belco Resources Equipment of any damages, issues or shortages to the machine.

Pre-Delivery Checklist - Dealer

- Gearbox oil level
- Check all fluids, hydraulic, gear oil, etc.
- Grease fittings properly lubricated
- Guards, shields, attachments securely fastened
- All hardware tightened
- Condition and tension of V-belts (if applicable)
- Blades properly installed, blade hardware tightened to proper torque specifications
- PTO attached to the machine (if applicable)
- All decals are clean, legible and in proper location
- Operator's Manual on machine

Model #: _____ **Serial #:** _____

Inspected by (Initials): _____ **Date:** _____

TO THE DEALER: Part 2 of 2

Dealer is to review the following items to the owner. Place a check mark in the box beside each item reviewed.

Checklist - Owner

- Correct attachment of machine to tractor
- Safe operation of the machine
- Importance of regular lubrication, maintenance and inspection
- Troubleshooting
- Replacing broken or worn parts (importance of using only OEM parts)
- Servicing the machine
- Storage
- Warranty
- Encourage owner to read and understand the Operator's Manual before operating the machine
- Encourage owner to fill out the "Warranty Registration", online warranty@br-equipment.com

Purchase Date: _____ **Delivery Date:** _____

Model #: _____ **Serial #:** _____

Dealer Signature _____ **Date:** _____

Customer Signature _____ **Date:** _____

TO THE OWNER:

Read this manual before operating your Belco Resources equipment. The information presented will prepare you to do a better and safer job. Keep this manual handy for ready reference. Require all operators to read this manual carefully and become acquainted with all the adjustment and operating procedures before attempting to operate. Replacement manuals can be obtained from your selling dealer. The equipment you have purchased has been carefully engineered and manufactured to provide dependable and satisfactory use. Like all mechanical products, it will require cleaning and upkeep. Lubricate the machine as specified. Observe all safety information in this manual and safety decals on the equipment. For service, your authorized Belco Resources dealer has trained mechanics, genuine Belco Resources service parts, and the necessary tools and equipment to handle all your needs. Use only genuine Belco Resources service parts. Substitute parts will void the warranty and may not meet standards required for safe and satisfactory operation.

Record your machine model and serial number in the space provide below. Your dealer will need this information to give you prompt, efficient service.

WARNING

MANDATORY TASKS

- **GREASING THE WHEEL HUBS:** after the first installation on the tractor, check that the wheel hubs are greased. – afterwards, check based on the task times and methods indicated in chap. “Maintenance”
- **WHEEL INFLATION:** after the first installation on the tractor, check the tire pressure. – afterwards, check based on the task times and methods indicated in chap. “Maintenance”.
- **TRACTOR SPEED FOR ROAD TRANSPORT:** do not exceed 40 km/h (Europe) - do not exceed 20 mph (USA).

CONTENT

INTRODUCTION	7
INFORMATION ON THE MANUAL	7
IDENTIFICATION AND EC CERTIFICATION	7
MAIN COMPONENTS AND TECHNICAL DATA	8
WARRANTY	9
SAFETY	10
GENERAL RULES	10
SAFETY DURING TRANSPORT, INSTALLATION AND MOVEMENTS	10
INTENDED USE AND PRECAUTIONS IN EMPLOYMENT	13
REASONABLY FORESEEABLE IMPROPER USE AND LIMITS OF EMPLOY	15
RESPONSIBILITY OF THE OPERATOR	15
PICTOGRAMS	15
NOISE LEVEL	17
RESIDUAL RISKS	17
INSTALLATION	18
PRELIMINARY INFORMATION	18
INSTALLATION TO TRACTOR	18
STABILITY OF THE MACHINERY (TRACTOR + EQUIPMENT)	19
ADAPTATION TO GROUND OF THE WHEELS	19
HYDRAULIC CONNECTIONS	20
REMOVAL	20
STORAGE OF THE HAY RAKE	20
OPERATION AND USE	21
HAY RAKE IN WORKING CONFIGURATION	21
WINDROW FORMATION	22
SPEED OF EXECUTION OF HYDRAULIC FUNCTIONS	23
WORKING PROCESS	24
CHANGE OF DIRECTION	26
PRESSURE ON GROUND OF THE WHEELS	26
MAINTENANCE	27
PRECAUTIONS DURING MAINTENANCE	27
MAINTENANCE TASKS	27
WHEEL AND TINE REPLACEMENT	28
TIRES	28
TROUBLESHOOTING	29
MATERIAL DISPOSAL IN CASE OF DEMOLITION	29
PARTS MANUAL	31

INTRODUCTION

Information about the manual

TAR RIVER (hereinafter named "Manufacturer") has designed and built the equipment in compliance with the safety regulations and with the precise intent of protecting both the working personnel and the entire operating system.

Every hay rake is equipped with a copy of this manual, which should be read carefully before using the equipment. The manual contains the necessary information for the equipment transport, use and maintenance and the corresponding safety regulations.

The lack of knowledge of its operating system could cause accidents that may cause damage to the equipment. Therefore, even if upon delivery, the Manufacturer supplies the Customer with all the information concerning the hay rake (operation, use and maintenance), he must, however, read this manual and follow the contained instructions.

The manual gives the basic guidelines for the best working conditions and safety, but the operator's experience and common sense remains the most important factor for the equipment functioning.

This manual was created according to existing hay rake model's specifications and design and does not take into account the similar models previously produced. However, the Manufacturer reserves the right to make changes to the models in production, in order to improve the product or where new regulations were enacted (Machinery Directive), without the obligation to update the previously built models.

This manual is part of the hay rake and, therefore, should be kept, clean and intact in all its parts and stored in a special container, placed on the equipment frame or inside the tractor cabin, ready for any consultation.

In case of sale of the hay rake it is important to verify that the manual is present. If the manual is missing, a duplicate must be requested to the Manufacturer.

If while reading the manual the instructions are incomprehensible, you should contact the Manufacturer, which will provide the necessary clarifications.

Warnings in this manual:

IMPORTANT

To indicate that the supplied information must be absolutely known by the operator;

HAZARD

To indicate a possible dangerous situation which concerns the operator and others' safety (minor accidents or injuries), or concerns the windrow rotary rake's efficiency;

The word **Note** indicates the topic can facilitate the work of the operator

Identification

Each machine has clearly visible identification plate applied on the frame where the following data as marked:

- the hay rake model (and/or version)
- the serial number
- manufacturing year.

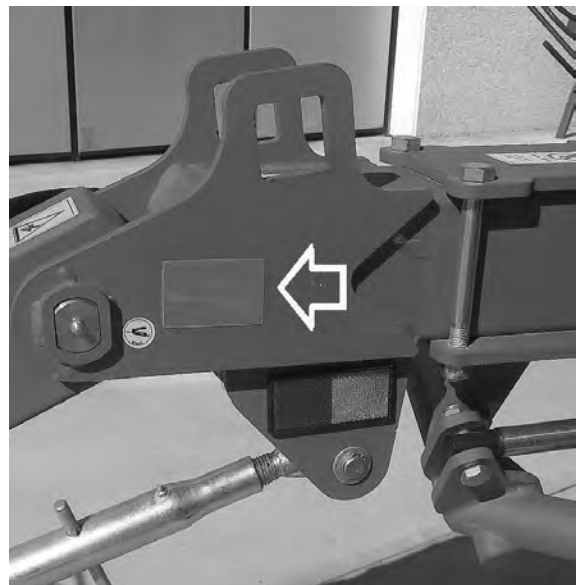
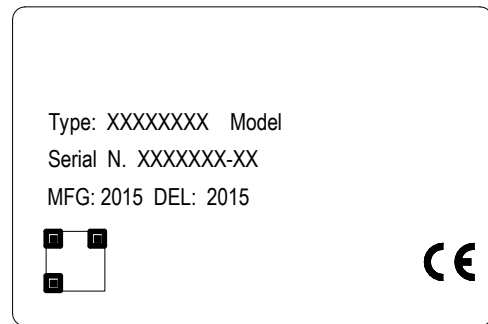

Refer to the data on identification plate when requiring assistance and ordering spare parts.

IMPORTANT

It is absolutely forbidden to alter and /or delete the data on the identification plate. The operator is required to verify the readability of data. If the data is unreadable, notify the Manufacturer to request a new identification plate, with the original data on it.

Main components and technical data

TECHNICAL SPECIFICATIONS	POWER RAKE 8	POWER RAKE 10	POWER RAKE 12
Transport length	18'	18'	21'
Transport width	8'	8'	8'
Working width with swath (max)	18' 11"	21' 8"	24' 3"
Swath width (min/max)	6' 5"	6' 5"	6' 5"
Wheel number	8	10	12
Wheel teeth	40	40	40
Wheel diameter	60"	60"	60"
Tractor power (HP)	40	50	50
Tractor working speed (MPH)	6 - 9	6 - 9	6 - 9
Wheel tires	2x195/65R15	2x195/65R15	2x195/65R15
Equipment weight (LBS.)	1,766	1,987	2,318

The data in the table about the working width, tractor power and weight are purely indicative and therefore not binding.

1. Rake wheel
2. Adjusting device of pressure/adherence of wheels on ground
3. Right lateral frame
4. Left lateral frame
5. Wheel
6. Main frame
7. Bearing foot
8. Hydraulic piping
9. Towing hitch
10. Fixing chain

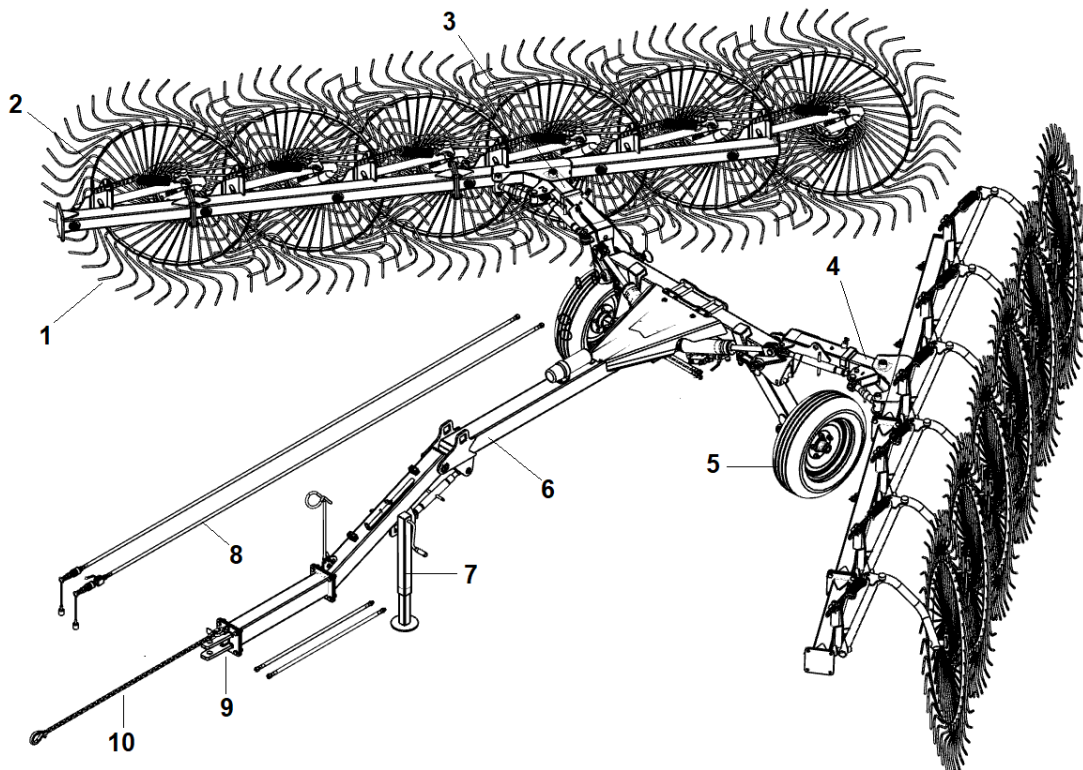



LIMITED WARRANTY

Belco Resources Equipment warrants to the original purchaser of any new piece of machinery from Belco Resources Equipment, purchased from an authorized Belco Resources Equipment dealer, that the equipment be free from defects in material and workmanship for a period of one (1) year for non-commercial, state, and municipalities' use, ninety (90) days for commercial use from date of retail sale. Warranty for rental purposes is thirty (30) days. The obligation of Belco Resources Equipment to the purchaser under this warranty is limited to the repair or replacement of defective parts.

Replacement or repair parts installed in the equipment covered by this limited warranty are warranted for ninety (90) days from the date of purchase of such part or to the expiration of the applicable new equipment warranty period, whichever occurs later. Warranted parts shall be provided at no cost to the user at an authorized Belco Resources Equipment dealer during regular working hours. Belco Resources Equipment reserves the right to inspect any equipment or parts, which are claimed to have been defective in material or workmanship.

This limited warranty does not apply to and excludes wear items such as shear pins, tires, tubes knives, blades or other wear items. Oil or grease is not covered by this warranty.

All obligations of Belco Resources Equipment under this limited warranty shall be terminated if:

Proper service is not performed on the machine.

The machine is modified or altered in any way.

The machine is being used or has been used for purposes other than those for which the machine was intended.

DISCLAIMER OF IMPLIED WARRANTIES & CONSEQUENTIAL DAMAGES

Belco Resources Equipment obligation under this limited warranty, to the extent allowed by law, is in lieu of all warranties, implied or expressed, including implied warranties of merchantability and fitness for a particular purpose and any liability for incidental and consequential damages with respect to the sale or use of the items warranted. Such incidental and consequential damages shall include but not be limited to: transportation charges other than normal freight charges; cost of installation other than cost approved by Belco Resources Equipment; duty; taxes; charges for normal service or adjustment; loss of crops or any other loss of income; rental of substitute equipment, expenses due to loss, damage, detention or delay in the delivery.

REGISTRATION

The online Warranty Registration must be completed in order to qualify for coverage on this Limited Warranty. Visit br-equipment.com, click on "Warranty Registration" and completely fill out the form to register the new piece of equipment.

SAFETY

General rules

This manual describes the safety standards to be observed when operating the hay rake. As most accidents occur due to the fact that basic safety norms are not respected, **it's obliged** before activating any function, to read this manual and carefully follow the contained instructions.

The use of the hay rake must be entrusted to an adult staff, qualified and trained for its use. **The Manufacturer, therefore, is not liable for accidents caused by the operator's negligence and/or the non-compliance with safety regulations. Moreover, in these cases, both the Manufacturer's responsibility and the hay rake's warranty will be instantly void.**

IMPORTANT

Personal protective equipment (PPE) during any operation of the machine (e.g. *assembly, disassembly, installation, removal, adjustment, maintenance, other*) in order to prevent health and safety hazards.



Use safety glasses, ear protection, safety shoes, gloves, helmet, tight fittings only of an **approved type**.

The use of mobile phones or radio/music headphones is strictly prohibited while driving and using machinery as they compromise the operator's attention.

Safety during transport, installation, movement and use

Transport (delivery): the equipment is fully dismantled and placed in a crate for the transport. The Customer can then re-assemble the parts quickly and easily on receipt, following the detailed instructions.

If the hay rake is sold or handed over to another user, the rake can be dismantled by following the instructions in reverse order, although it can also be delivered fully assembled. If the distance and conditions are such that the hay rake cannot be transported by road hitched to the tractor, it can be easily put on a suitable means of transport, as shown in the **fig.3**.

The hay rake is loaded or unloaded via a ramp attached to the vehicle. The equipment, **in transport configuration**, is reversed onto the vehicle, then harnessed in place and fitted with all necessary safety devices for transport.

IMPORTANT

Do not forget that, for transportation and handling, the hay rake must be in its transport configuration as described in the chapter "Moving the rake".

WARNING

To indicate a possible dangerous situation which concerns the operator and others' safety (minor accidents or injuries), or concerns the hay rake efficiency.

HAZARD

Loading and unloading operations always lead to dangerous situations. That's why it's necessary that operators always act with caution.

The word **Note** indicates the topic can facilitate the work of the operator

- Operations must always be carried out on an even surface and by respecting a safety distance from slopes or ditches;
- Make sure that ramps are sufficiently robust to support the hay rake, that they are firmly anchored to the vehicle frame, parallel between them and perpendicular to the side of the vehicle;
- Verify that the ramps are clean without any trace Of oil, grease or ice.

fig.3

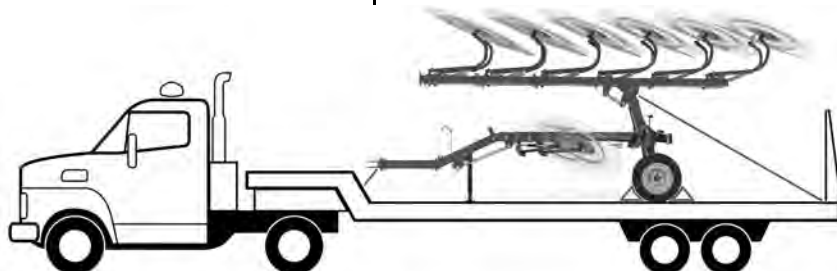
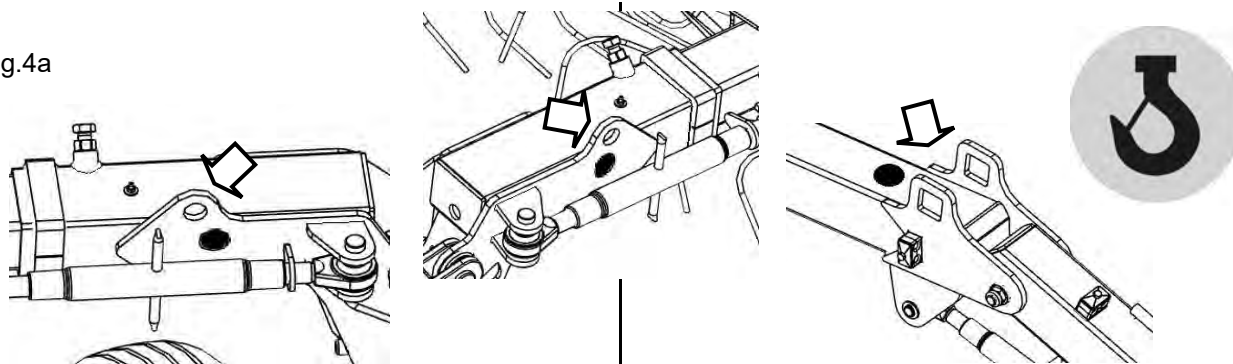

fig.4a



- On the ramps, during the hay rake ascent or descent operations, direction must never be changed. In case a correction of direction is needed, bring the equipment back and proceed with the correction.

Lifting: in the case, the equipment used must have suitable characteristics and slings to support the hay rake, which total weight is indicated on the identification plate. Trained personnel will perform the operations, holding the equipment on the points marked on the frame and provided for that purpose.

Note: in order to preserve the frame integrity we recommend holding the hay rake with approved straps instead of chains. - However, on the points where it should be held a pictogram was applied, containing a hook (as shown in the fig.4a), to highlight the use.

In the event that it is necessary to lift the rake with a jack, to replace a wheel or to carry out specific maintenance, the points provided for the intervention are appropriately marked on the chassis. Suitable pictograms (fig.4b) are applied in the vicinity of the jack positioning. For the procedure for the safe use of the jack, see the relevant paragraph in chap. Maintenance

Installation: The hay rake can be installed on any tractor equipped with a tow hitch and rear auxiliary hydraulic.

IMPORTANT

The tractors must be provided with protective Roll-bar or ROPS or FOPS approved cabins, as indicated by the current Standards. **It's strictly forbidden to install the equipment on tractors without these protection devices.**

However, before installation, the Customer must ensure, by consultation of the related use and maintenance manual, that the tractor has the necessary requirements for the use and functioning of the hay rake and/or needs ballast to eliminate any imbalance that may lead to its overturn. See also Stability of the Machinery page 17.



For the hay rake installing instructions and any hydraulic and electrical connections refer to the relative sections described below. For the PTO drive-line shaft instructions, refer to the ones supplied with the accessory.

Movement on the road: the hay rake can travel on the road only if attached by the tow hitch to a tractor. For such movement it is important that:

- the equipment is arranged in the **transport configuration** (see next point) and that on it up to present and clearly visible the devices (approved) that indicate its dimensions, as required by the Highway Code.
- the road lighting and reflected light devices on the equipment and on the tractor are intact and functioning;

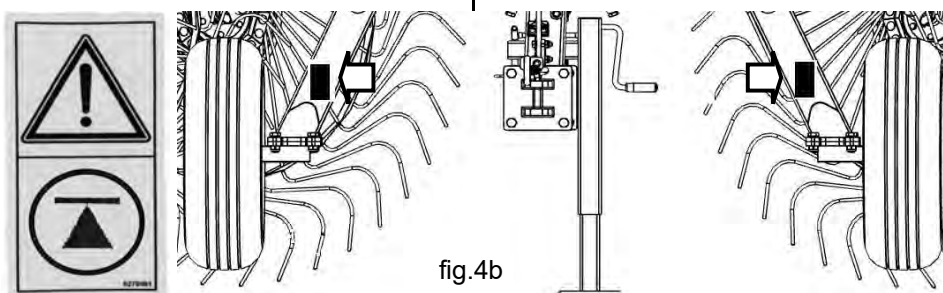

fig.4b

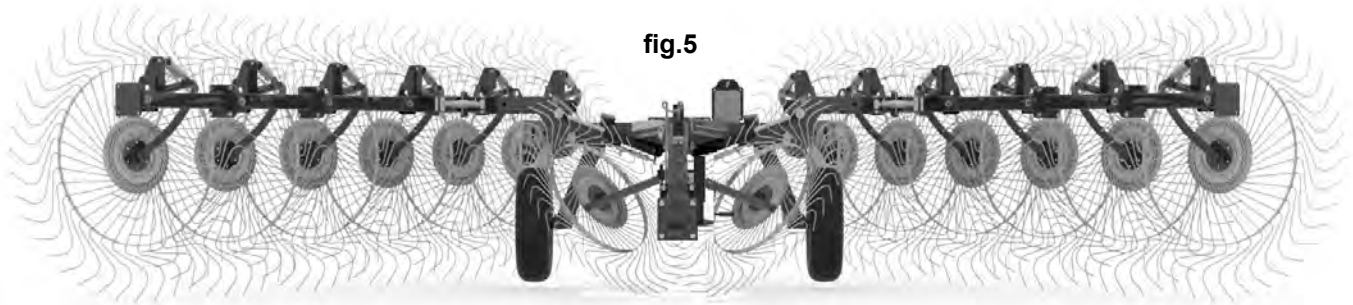

fig.5

WORKING CONFIGURATION

- the fixing devices to the tractor (pin and, if any, chain,) are correctly installed and secured;
- while driving, the relevant rules of the Highway Code are observed;
- are not exceeded 20 mph. Some rough terrain requires an even slower speed. A sudden steering or braking could cause the towed load side skid and/or overturning with consequent damage to the equipment, the tractor and even the operator in the cab;
- are not exceeded 5 mph when turning and on slopes. Also in these cases, there is a danger of side skid and/or overturning, see previous point.

Note: If the moving frames do not lift evenly, it means that the adjustments on them, in the working configuration, have not been made in the same way. It is recommended to return the mobile frames almost to working configuration, leaving them raised a few centimeters above the ground and make the correct adjustments. See relevant paragraphs in chap. Operation and Use.

2. (in presence of kicker wheel) equipment right side under frame central spar – close the tap on the hydraulic circuit of the kicker wheel (fig.7);

Transport configuration

To put the rake from the working configuration (fig.5) to the transport one (fig.6), it will be necessary:

1. start the tractor engine and after few minutes, in cabin, by handling the relative control lever of the auxiliary hydraulic circuit, to lift the mobile frames and, if presents, the central wheels.

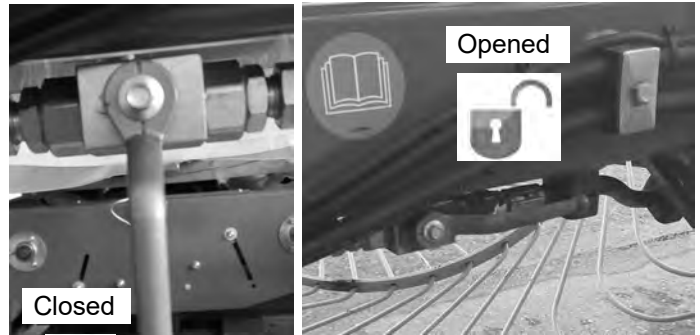

fig.7

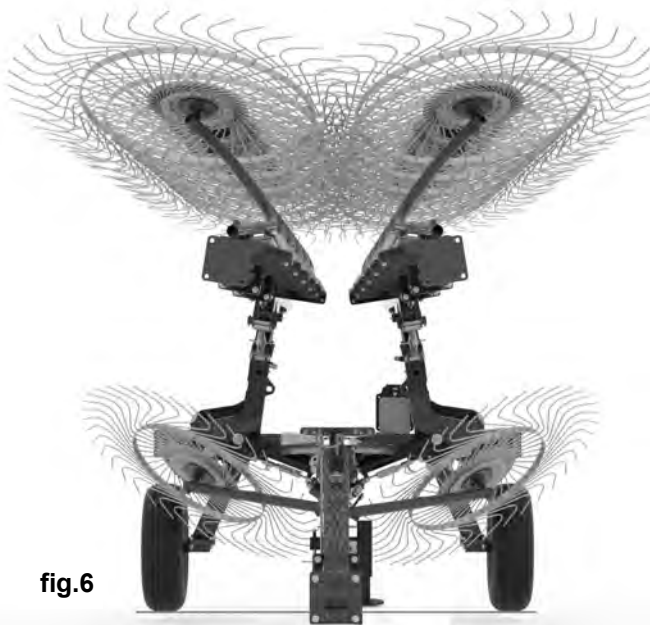

fig.6

TRANSPORT CONFIGURATION

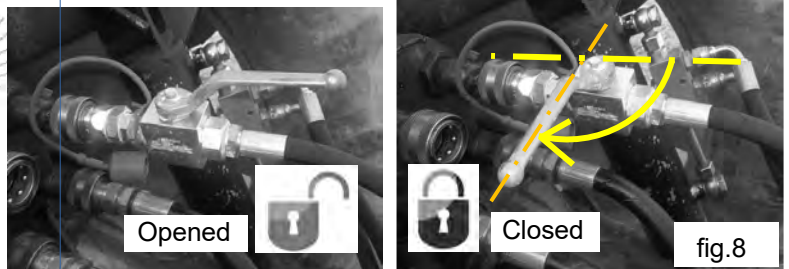

fig.8

3. tractor hydraulic outlet - close the tap on the hydraulic circuit of the hay rake (fig. 8).
- **warning lights:** the tractor must have the beacon warning light (yellow or orange) always activated.
 - **weight:** the total weight of the operating machine (tractor with hay rake) must not exceed 30% of the tractor weight on its own as reported on the registration certificate.

The tractor must always circulate at moderate speed, especially on rough roads, as the rear weight could cause difficulties driving;

- **regulations:** it is however necessary to know and follow the rules for road circulation in force in each Country.

When circulating on-road with the operating machine (tractor with hay rake), the operator in the cabin must always observe the following precautions:

- **prohibition** of carrying passengers on the tractor;
- **prohibition** of carrying people, animals or things on the equipment;
- **always adapt the driving speed to the road conditions and not to exceed 20 mph.**

Field displacement: when moving in the fields with the operating machine (tractor with hay rake) there is no need to turn on any lights or sounds or to display any type of panel. Place the hay rake in the **working configuration** just before operating.

Warnings:

- before reversing the tractor, always make sure the hay rake is **NOT** in its working configuration –

if it is, lift the mobile frames from ground just Enough (20" - 24") to perform the maneuver safely. If not, the rake could cause or sustain damage;

- **if the plane is inclined (fig.10)**, the movement of the machinery (tractor + equipment) must preferably result parallel to the slope direction.

If the machine were to be moved transversely to the slope, it would be preferable to lower the mobile frames as, during the working process, reversing or direction changing at the end of the field with the tractor (fig.10b - see pages 12 and 23). The same precaution applies to changing the direction of the tractor. In any case, it is also essential to follow the instructions described in the tractor use and maintenance manual.

Intended use and employment warnings

The hay rake is an agricultural equipment used to collect any type of previously cut forage with a formation of windrows.

The hay rake can only operate if it is hooked to the towing hook, installed behind every tractor, because the operation is obtained by effect of its drag. The consequent wheel rotating motion allows their tines to lift the forage from the ground and at the same time to move it laterally, allowing the formation of uniform and well-ventilated windrows.

fig.10a

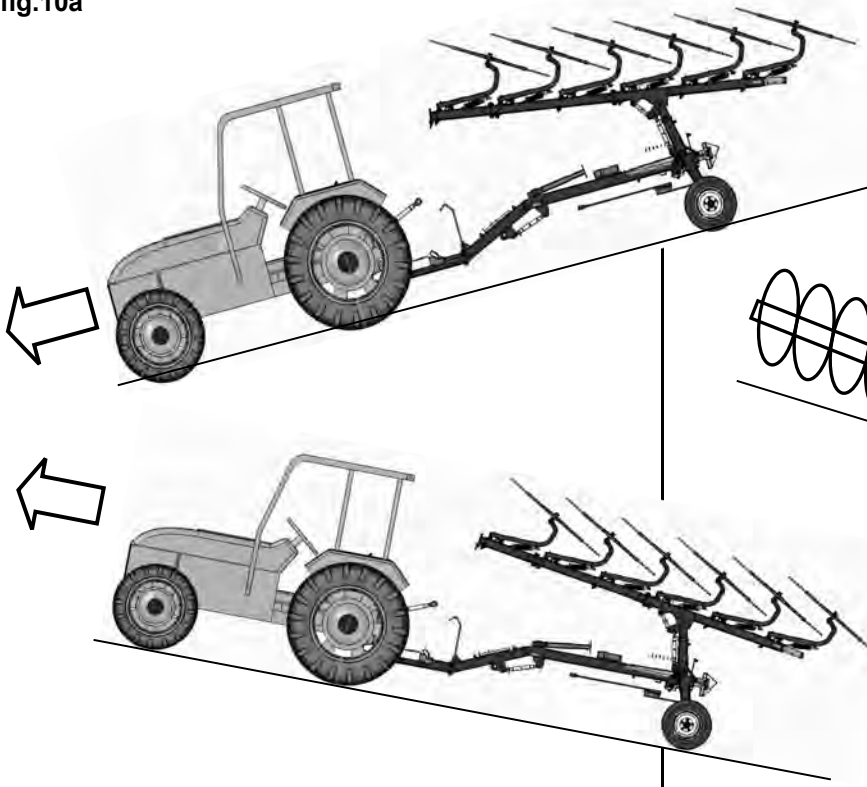
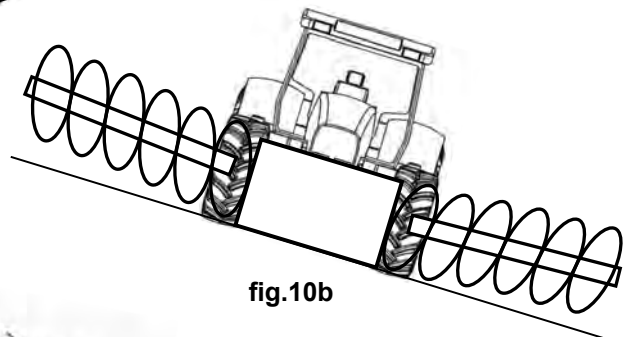

fig.10b



The hydraulic circuit of the hay rake is supplied by the tractor auxiliary one, by means of piping equipped with quick couplings, and therefore controlled, from the cabin, by the respective lever.

The hay rake must only be used by a qualified operator who's trained for its use and operation.

Safety is of prime importance for the personnel working around the equipment or performing Repairs or maintenance tasks. Given that the provided instructions cannot cover all possible working situations and related danger, the operator should always use caution and common sense.

Precautions before use:

- verify the presence and integrity of all the blocking and safety devices;
- **do not use** the equipment if there are broken or damaged parts, especially of protection ones;
- perform the daily maintenance tasks (as described in the relative paragraph). – **Note:** *regarding this, remember that any type of task (control, adjustment, maintenance or other) should always be performed with the equipment not in motion and the tractor engine switched off;*
- the operations of the equipment are allowed in **good visibility conditions**. In case these conditions lack, even partially, operations should be interrupted as even the normal safety conditions are absent. - The operations can be Resumed only when good visibility conditions are restored;

- ensure that there are no people or animals in the area between the tractor and the hay rake or in any of the equipment **dangerous areas** (shown in the fig.11), as they may not be aware of possible danger.

Precautions during use:

- during operations, always maintain the tractor speed within 10 mph;
- **the operator must never abandon the tractor with its engine on.** Even for short working breaks, he must always switch off the tractor's engine, engage the parking brake and remove the key from the ignition;
- during work breaks, the operator must not allow unauthorized and/or unqualified personnel to replace him;



- before **reversing** or **direction changing at the end of the field** with the tractor, check if the hay rake is **NOT** in working configuration – if it is, lift the mobile frames from ground just enough (20” - 24”) to perform the maneuver safely. If not, the rake could cause or sustain damage. For the mobile chassis lifting, also partially, handle, in cabin, the corresponding lever of the tractor auxiliary hydraulic system (also see paragraph Change of direction or in reverse).

with regard to the noise emitted by the equipment, see information in the section "Noisiness".

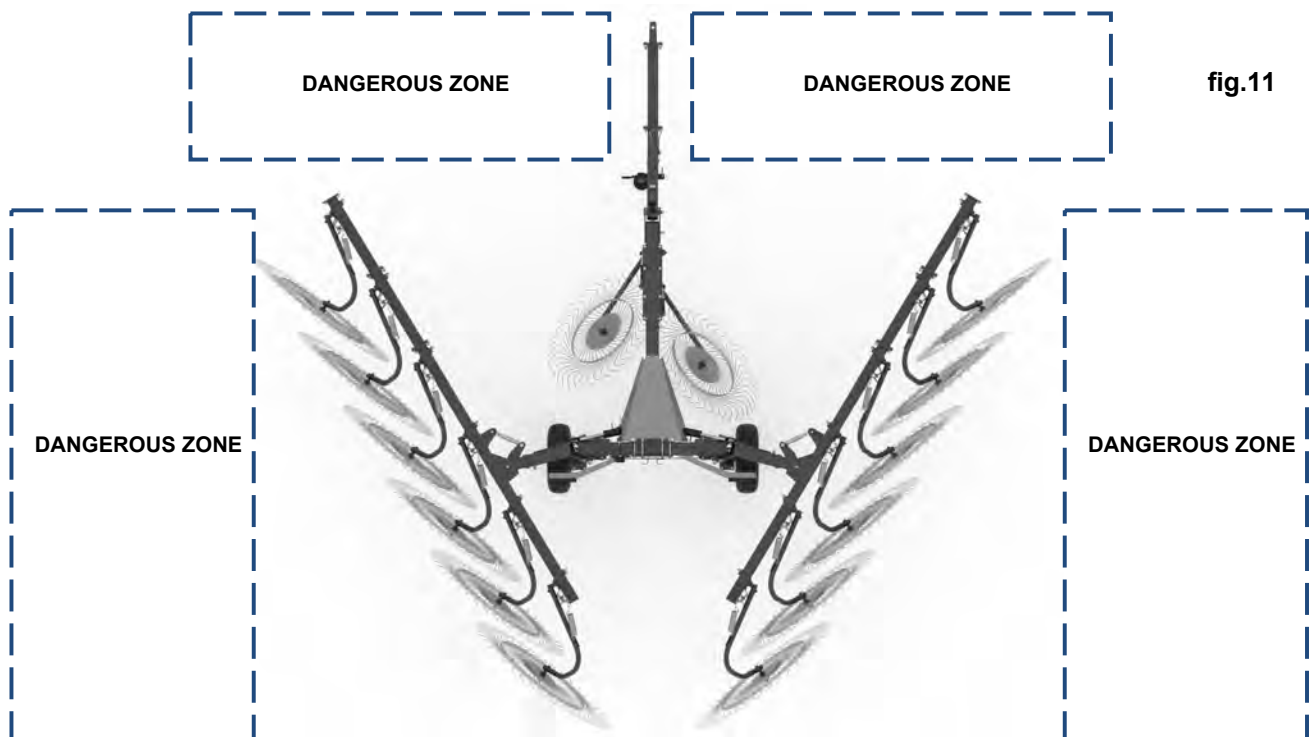

fig.11

Immediately interrupt work operations when:

- you are in proximity of resistant objects, such as manholes, wells, trees, etc. as contact could break the tines, and project the pieces all around at a very high speed;
- you hear noisy vibrations coming from the equipment. To avoid possible damage, the operator should stop the tractor, switch off the engine and if possible, identify and remedy the situation, always respecting the safety regulations.
- there is an oil leak on the pull-type version of the hay rake. Never search for the leak bare-handed, but use a piece of fabric or protection gloves. Oil under pressure may penetrate in the skin causing serious infections.

Reasonably foreseeable improper use and limits of machine

A different use of the hay rake from the one described in the previous paragraph **is considered improper and therefore forbidden**. In addition, the technical characteristics of the equipment must not be modified in any way to alter its performance. **In case this should happen anyway, both the equipment warranty as the Manufacturer's liability will immediately become void.**

Visibility: in conditions of insufficient visibility (fog, dust, smoke or other): it is advisable to stop the tractor and to wait until that fog, dust or other circumstance vanishes. Operate at the same way in case of **wind** and/or **rain**.

Dangerous areas: if, during the working process, a person or an animal goes in one of the dangerous areas (see previous paragraph), the operator must immediately stop the tractor and provide to put the intruder on a distance. Also during the adjusting and/or maintenance tasks, these areas remain dangerous and outsiders must not stay or move in the proximity of the equipment.

Don't use the equipment when:

The cut product is wet or damp. Under these conditions, it becomes sticky and easily accumulates on tines, limiting them operational function.



no operations should take place nearby concrete. In these cases apart from the possibility to damage the tines there could also be a dangerous projection of relative residues.

In case of any doubt about the use of the hay rake and you don't find it included in this manual please contact the Manufacturer.

Responsibility of the operator

Each operator is directly responsible for the operational control of the hay rake for maintenance, repairs and/or spare parts replacement. This means that no operator can delegate someone else, who has not the same requirements, to replace him in his duties. As the instructions in this manual cannot cover all the possible situations of danger, each operator must always use caution and common sense. Therefore, everyone becomes liable for the damage caused to themselves, others, animals or damage to things when:

- using the equipment in a wrong, improper way;
- using the equipment under the influence of alcohol, drugs, pharmaceutical drugs or in a state of tiredness or illness;
- wearing unsuitable clothes that may entangle in moving or rotating bodies;
- appears to not be aware of the instructions in the manual;
- does not observe road and safety regulations currently in force;
- not verifying the requirements required in advance, the coupling to the tractor is not appropriate (power or characteristics differ from those listed in the technical data table);
- not carrying out the necessary maintenance tasks, which although simple, if not performed properly can result in equipment damage and create safety hazards to people;
- modification of the machinery or performing unauthorized interventions;
- using non-original or specific spare parts for the hay rake.

Pictograms

In addition to the indications contained in this manual, adhesive labels or pictograms that illustrate the safety regulations to be respected are applied on various parts of the machinery to help operators. The labels vary in shape and color and provide additional information on safety standards to be respected. Regulations illustrated by the labels on the hay rake are:

1U - Danger: Keep a safety distance from the equipment when the mobile chassis are lowered;

2U - Caution: see chap. Safety point General rules;

3U - Warning: danger of flying objects. With the rotation of wheels, the tines could pick up and launch objects from the working site. Minimum safe distance m20;



Externally on both the mobile chassi

1U

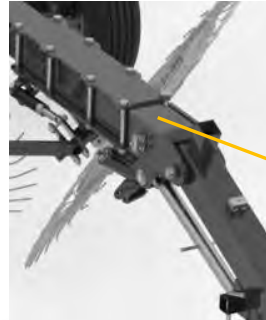

2U

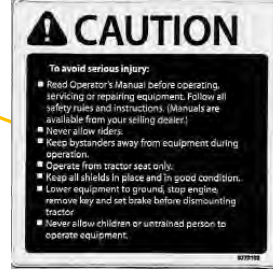

3U

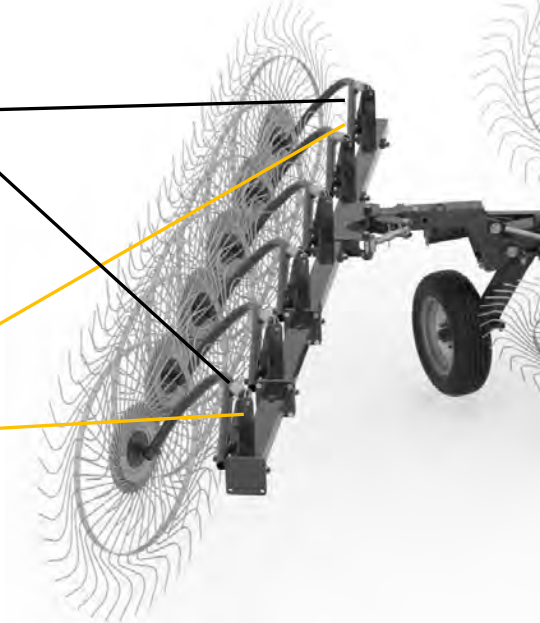

4U



5U

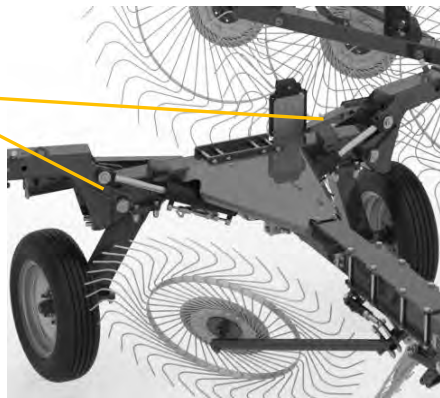

6U

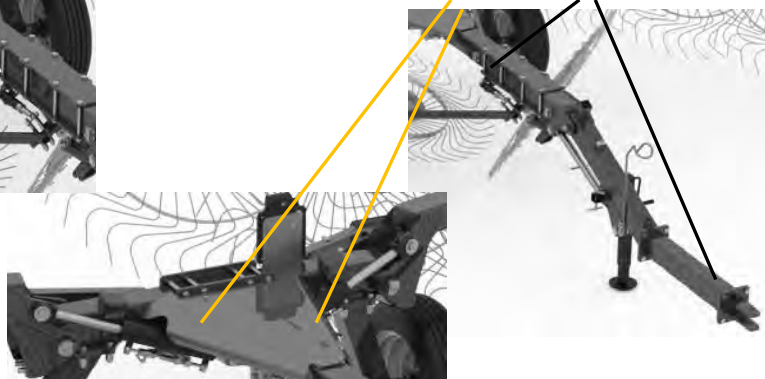
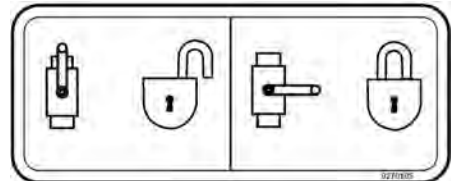

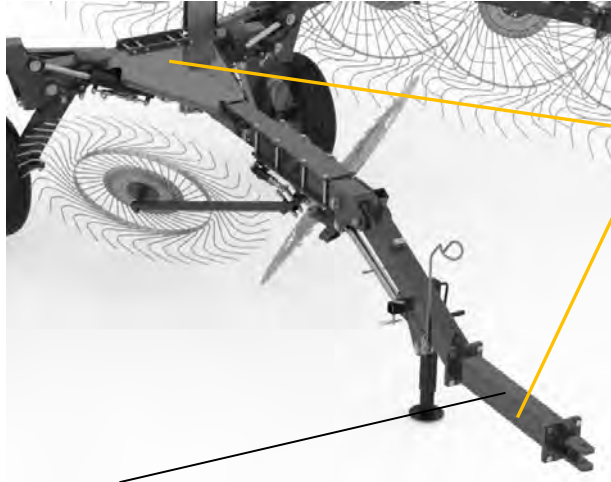

7U

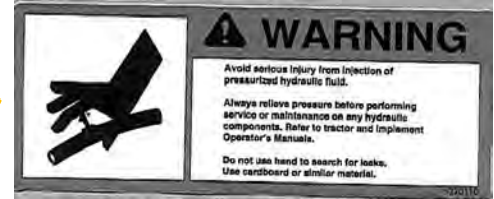

8U



4U - Prohibition to stand or transit. It is forbidden for persons not in charge to stand or move inside the operation area of the hay rake, when this one is running. The intruders are exposed to dangers of entanglement with bodily injuries. Stand at a safety distance (m. 20).

5U - Caution of injury or crushing upper limbs: with the lifting of mobile chassis, the upper limbs are exposed to the danger of crushing;

6U - Cylinder operation: On/Off;

7U - Danger of injury or scald due to leaks of pressurized hydraulic fluid. Do not use hand or fingers to search for leaks. Use cardboard or similar material.

8U - Body injury danger: Keep a safety distance from the equipment when the mobile chassis are lowered

IMPORTANT

Warning labels and pictograms must be replaced before they become illegible. Should one of them become illegible, the operator cannot use the hay rake until a new label is applied. It is also strictly forbidden to remove the pictograms or labels from the equipment. Should this happen, the Manufacturer declines every responsibility this might entail, as the hay rake would no longer have the safety requisites it was designed and built with.

Noisiness

The sound level at the driver's seat may vary depending on the type of tractor cab.



The operator is obliged to wear an appropriate hearing protection device if the sound level reaches or exceeds 85 dB(A).

This device must be available on the tractor if the sound level reaches or exceeds 80 dB(A).

Instead about the noise produced from the tractor engine, it is opportune to consult the relative use and maintenance manual.

Residual risks

Lower limbs and/or body injuries: loss of stability in phase of parking caused by the non-installation of the bearing foot.

INSTALLATION

Preliminary information

The hay rake can be installed on any tractor equipped with a long hitch and rear auxiliary hydraulic outlets. The installation must be carried out on a specific area with a flat surface.



The installation must be performed by one or more qualified operators and to knowledge of the safety norms required by the intervention. Use **Personal protective equipment** (see Safety page 10).

Besides, it is necessary that the equipment is placed inside an area, foreseen for the intervention, with plain surface and free from objects or other material and from unauthorized personnel and/or animals

Installation on the tractor

The operator must approach the hay rake slowly, placing the tractor in a way to perform the centring easily (1).

IMPORTANT

The alignment between the tractor coupling holes the hay rake holes (intervention called **centring**) must be performed with the utmost care and caution.

Fig.13.1 - When the tractor is near the hay rake coupling point, an operator on the ground, by acting on the bearing foot crank (2) raises or lowers the hay rake coupling point in order to make it horizontally coincide with the tractor.

Fig.13.1 - After the coupling, the operator inserts the locking pin (3) in the corresponding holes of the coupling point, as shown in the fig.12, and then secures it with the respective R cotter pin or safety pin (4).

Fig.13.1 - Next, the operator turns the handle (5) on the bearing foot to lift the latter as high as necessary to move it from its position to that required for trailing the rake.

Fig.13.4 - To remove the bearing foot: remove the R cotter pin (6), pull out the handle pin (7) from its seat and take the bearing foot out of its housing (8). Next, turn the foot anti-clockwise, as shown in fig.13, and insert it in housing up (9), foreseen for the working phase. Insert the handle pin (7) in its new seat and fasten it by its R cotter pin (6).

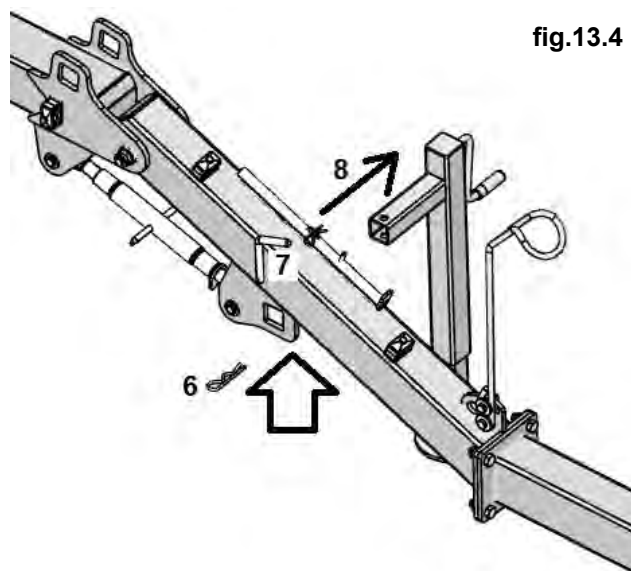

fig.13.4

Fig.14 - Complete the installation mounting the safety chain to the tractor drawbar support.

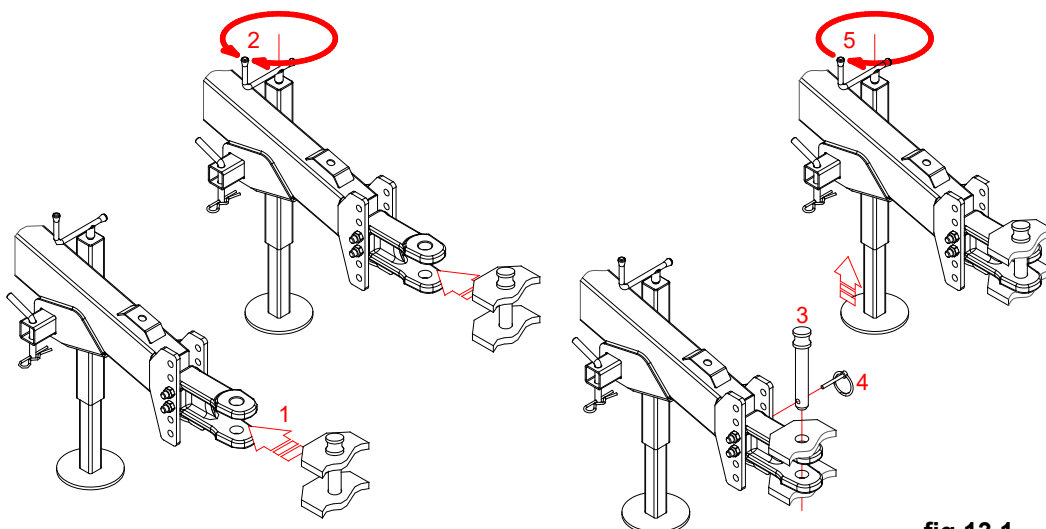

fig.13.1

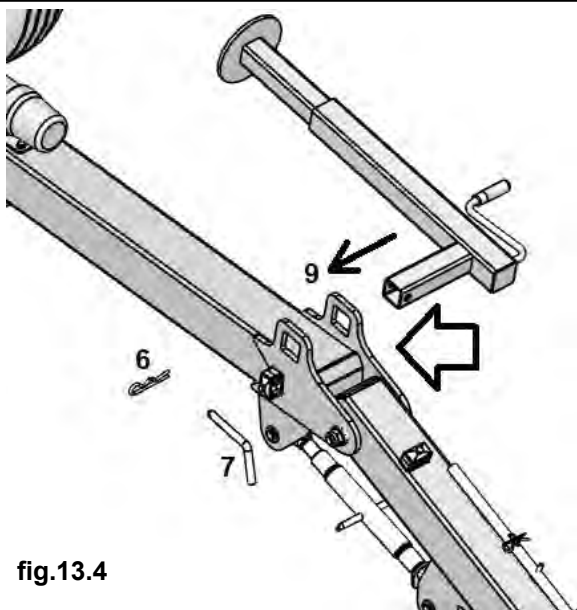

fig.13.4

The safety chain will help control drawn equipment should it accidentally unhook from the draw bar (fig.14.1).

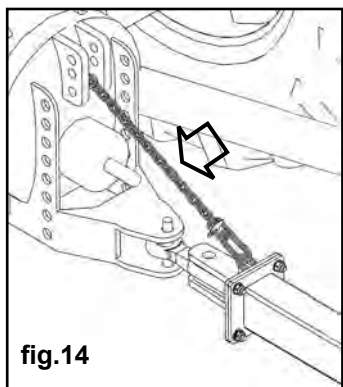

fig.14



fig.14.1



HAZARD

Do not use safety chain for towing.

Stability of the machinery (tractor + equipment)

Fig.15 - The weight of the equipment will change the stability of the machinery (tractor + equipment) affecting its steering and braking capability.

In particular, keep in mind that the front axle should support at least 20% of the weight of the machinery. Check the lifting capacity and the stability of the tractor using the following formula and add ballast to the front of the tractor, if necessary.

fig.15

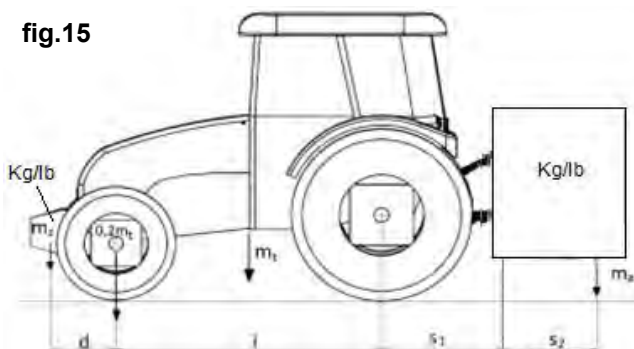

$$mz \times (d+i) \geq ma \times (s1 + s2) - (0,2 \times mt \times i)$$

FIRST VALUE

SECOND VALUE

- i: tractor pitch;
- d: horizontal distance between the center of gravity of the front ballast and the front axle of the tractor;
- s1: horizontal distance between the center of gravity of the tractor and the lower connection points of the equipment;
- s2: horizontal distance between the lower connection points of the equipment and the center of gravity of the disc mower;
- mt: tractor kerb weight;
- mz: ballast weight;
- ma: equipment weight.

Adaptation to ground of the wheels

Following the first hitching of the rake to the tractor Tow bar, in working configuration, any wheels (front or rear) can no touch the ground. **The rake chassis is not parallel to the ground.**

To obtain this condition, it is necessary to act on the adjustable tie rod, placed under the rake draw bar (fig.16a).



fig.16a

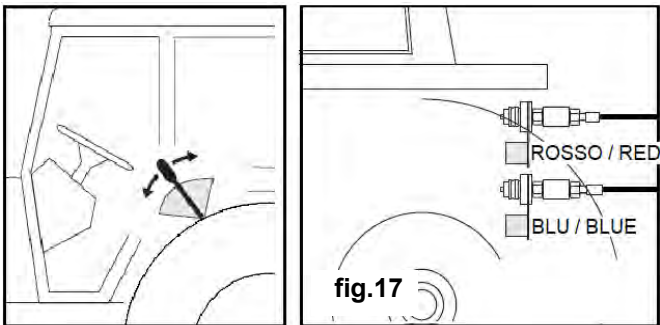

fig.16c

The tie rod can be only manually adjusted. - Loosen the safety lock (fig.16a - **A**) before performing the adjustment. - To maneuver the tie rod, use the special tool, provided by the Manufacturer, and installed on the rake drawbar (fig.16b and 16c). - Tighten A safety lock.

Hydraulic connections

The hydraulic cylinders serve to move two mobile chassis and, if available, the central kicker wheels, for setting up the hay rake in its transport or working configuration.



The cylinders are powered by the tractor auxiliary circuit and controlled by means of the respective lever in the driver cabin.

Therefore, it is necessary that the hydraulic piping (with red cap for the delivery and blue cap for the return one, both equipped with quick coupling, fig.17) are connected to the auxiliary circuit of the tractor.

Electrical connections

Plug the electrical plug of the light devices on the rear bar of the rake (fig.18 / 7 poles – **E3**) to the relative rear socket (fig.18) of the tractor auxiliary electrical circuit.

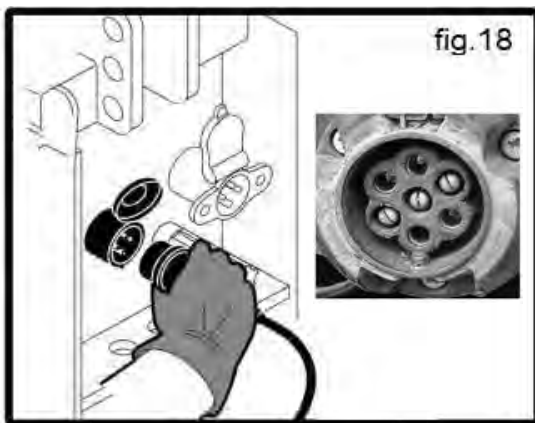

Greasing hubs

WARNING

After the first installation on the tractor, verify that the wheel hubs result greased, and if necessary, do it. Also carry out a tire pressure check (see paragraph E5).

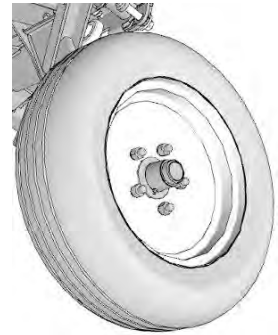

Afterwards, grease the wheel hubs and check the tire pressure based on the task times and methods indicated in the chap. Maintenance.

Removal

For the removal of the hay rake from the tractor follow the above instructions, described in the previous paragraph, in reverse order.

Storage of the hay rake

The Customer must provide a storage area within his premises for the equipment ensuring it has a large and comfortable access. For the storage of the hay rake the following interventions are required:

- if not already done, put the hay rake in the transport configuration;
- park the equipment in a safe and secluded area, on a flat and consistent surface;
- place the bearing feet for the parking phase (see fig.13.4); and remove the bar rake from the tractor (see previously paragraph);
- remove the tractor from the hay rake;
- protect the equipment with a tarpaulin.

OPERATION and USE

For any type of task (check, adjustment, maintenance or other) wear the associated **PPE**. It is well to remember that each intervention **should always be performed with the equipment stopped and the tractor engine off**;



Hay rake in working configuration

The hay rake will be driven to the workplace and before using the equipment, the operator will provide to put it in the required working configuration:

1. All wheels operating (the central ones too, if there are)

- a. Open the tap on hydraulic circuit of the hay rake (fig.20a) and the one of the kicker wheel, if there is (fig.20b);

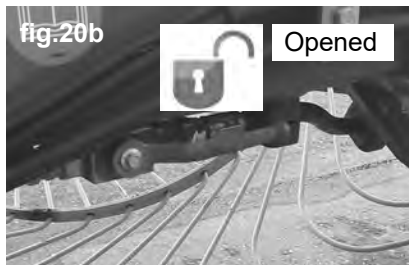

- b. In cabin, by handling the corresponding control lever of the auxiliary hydraulic circuit, lower completely the central wheels and the mobile frames (fig.21).

IMPORTANT

If the mobile frames have to be pulled out and/or placed on the ground with a different angle, then it is advisable to perform these tasks before they are completely lowered.

To adjust the width of the windrow (extension of the mobile frames) and the forage harvesting (angle of the mobile frames), consult the respective paragraphs

In the event that the lowering or raising of the mobile frames and/or central wheels is too fast (or slow), adjust the respective control valves. Consult the respective paragraphs.

2. All wheels operating (except the central ones, if there are)

- a. Open the tap on hydraulic circuit of the hay rake (fig.22a) leaving closed the one of the kicker wheel (fig.22b);

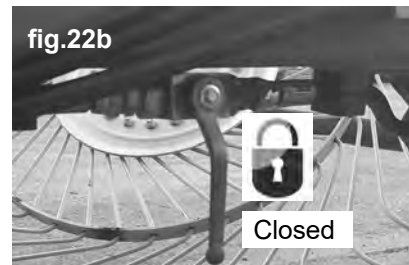
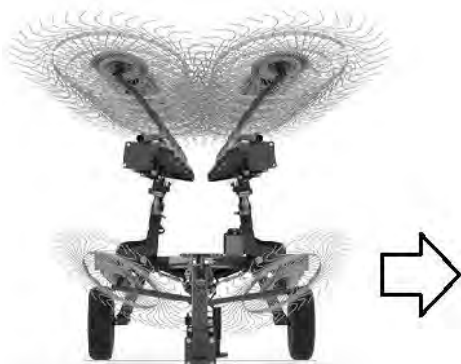

fig.21



TRANSPORT CONFIGURATION



WORKING CONFIGURATION

b. In cabin, by handling the corresponding control lever of the auxiliary hydraulic circuit, lower completely the central wheels and the mobile frames (fig.21).

IMPORTANT

If the mobile frames have to be pulled out and/or placed on the ground with a different angle, then it is advisable to perform these tasks before they are completely lowered.

To adjust the width of the windrow (extension of the mobile frames) and the forage harvesting (angle of the mobile frames), consult the respective paragraphs

In the event that the lowering or raising of the mobile frames and/or central wheels is too fast (or slow), adjust the respective control valves. Consult the respective paragraphs.

3. RH (or LH) Lateral wheels operating (except the central ones, if there are)

- a. Close the valve on the mobile frame cylinder that must remain lifted (fig.23a);
- b. Open the tap on hydraulic circuit of the hay rake (fig.23b) leaving closed the one of the kicker wheel (fig.23c);

fig.23c

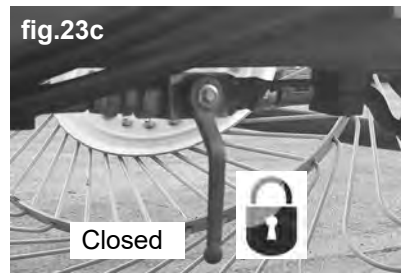

b. In cabin, by handling the corresponding control lever of the auxiliary hydraulic circuit, lower completely the mobile frame prearranged to operate (fig.24).

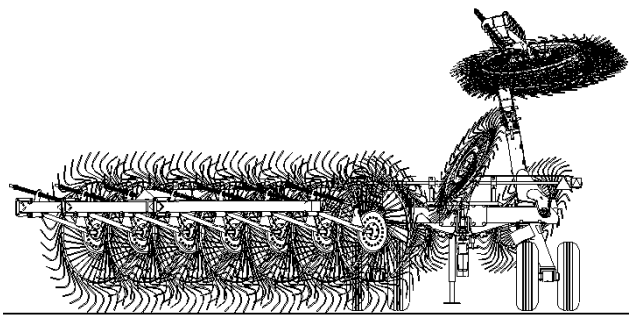

OPERATING WHEELS ON LEFT SIDE

fig.24

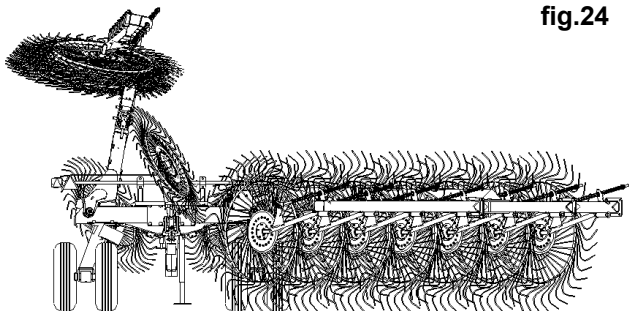

OPERATING WHEELS ON RIGHT SIDE

fig.25

fig.23a

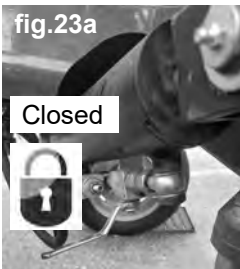
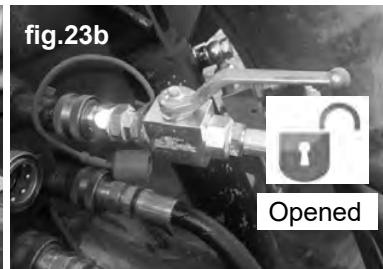

fig.23b



Windrow formation

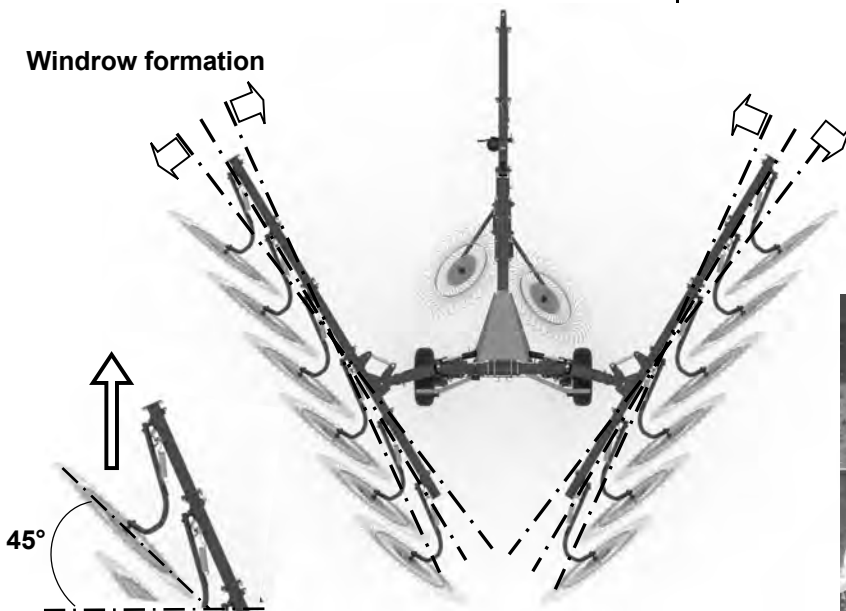

fig.26a

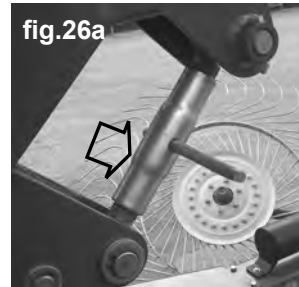

fig.26c



fig.26b



- **Inclination of wheels:** for optimal use, the wheels must have a grade of about 45° respect to the forward direction (fig.25 - page 28).

To adjust such grade do act on the adjustable tie rods (fig.26a - page 28), each placed on the respective mobile frame. Appropriately adjust the wheel tilting to the working process. **Do not act on the wheels.**

Note: the tie rods are only manually adjustable. Perform both mobile frames evenly and with them slightly raised from the ground. - To maneuver the tie rod, use the special tool, provided by the Manufacturer, and installed on the rake drawbar (fig.26b and 26c).

- **Width draw width:** its formation (or width) can be adjusted by pulling out the mobile frames from respective support (fig.27). The maximum extension for side is **20 cm** (fig.27).

To pull out or retract the mobile chassis do act on the adjustable tie rods (fig.28a), each placed on the respective mobile frame.



Note: the tie rods are adjustable manually only. Perform both mobile frames evenly and with them slightly raised from the ground. - To maneuver the tie rod, use the special tool, provided by the Manufacturer, and installed on the rake drawbar (fig.28b e 28c).



Speed of execution of hydraulic functions

if the execution of hydraulic functions of the mobile chassis and/or kicker wheel be very fast or slow, to act as follows:

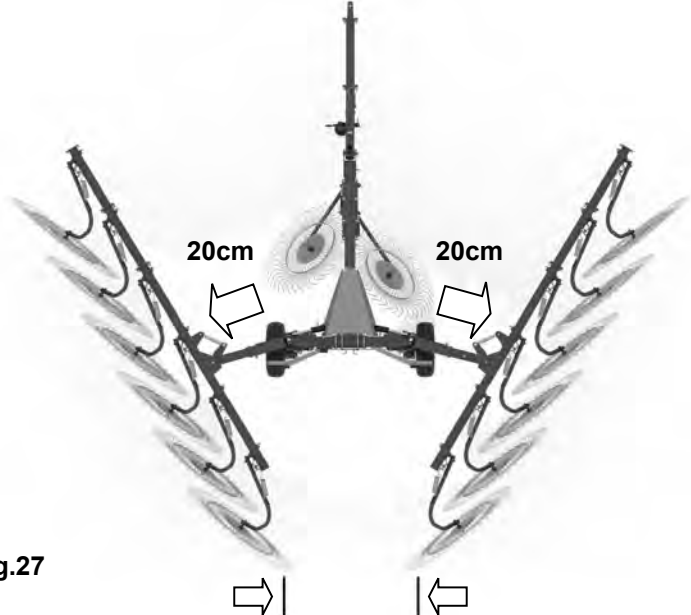
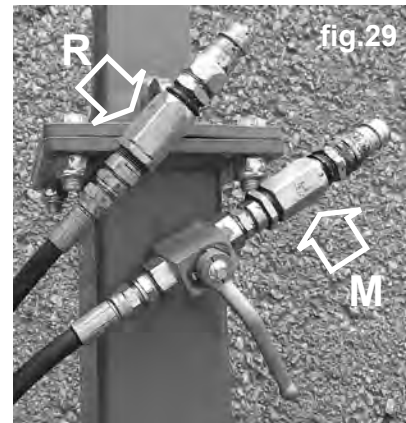
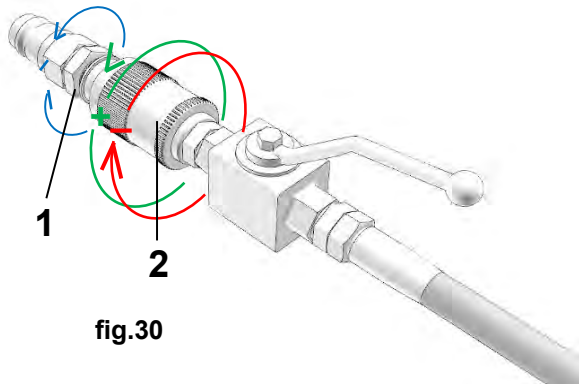

fig.27

- **Lowering of mobile chassis:** act on the flow regulating valve on the delivery piping (fig. 29 – M - page 29). - **If there are, tap of kicker wheel hydraulic circuit closed** (fig.29a).



- loosen locking ring nut 1;
- rotate the valve in – (less) direction until to stop point;



- rotate the valve in + (more) direction of half lap at the time and, time by time, to perform an operational test of the function, by acting on the corresponding lever in cabin;
- when the test results satisfactory, to screw the ring nut 1 until that the valve results locked.

- **Lifting of mobile chassis:** act on the flow regulating valve on the return piping (fig. 29 - R). - **If there are, tap of kicker wheel hydraulic circuit closed.**

- loosen locking ring nut 1;
- rotate the valve in – (less) direction until to stop point;
- rotate the valve in + (more) direction of half lap at the time and, time by time, to perform an operational test of the function, by acting on the corresponding lever in cabin;

- when the test results satisfactory, to screw the ring nut 1 until that the valve results locked.
- **Kicker wheels, if there are:** act on the throttle valve on the T union (hay rake right side), shown in fig.31.

- loosen locking nut 1;
- insert an allen key in the grub screw 2;
- rotate the key (a quarter of a turn at a time): clockwise to slow down the lowering of kicker wheel / counter-clockwise to speed up the lowering of kicker wheel;
- when the test results satisfactory, to screw the locking nut 1 until that the valve results locked.

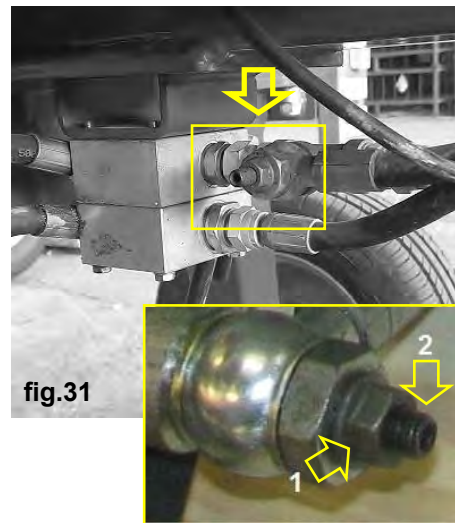

Working process

IMPORTANT

The operator will check for any people or animals in the immediate vicinity or in the working area before beginning the working process; if there are, he will move them to a safe distance.

The rake is extremely easy to use in that it just has to be hitched onto the tractor and then trailed in the required direction.

In this way, the teeth on the wheels are pulled along the surface of the ground as the rake is trailed and by turning effect of the wheels form regular and uniform heaps of hay or forage called **swaths** or **withdraws** (see fig.33 and 34).

Note: *it is also possible to convey the product from one side toward the center when required for particular working process (see previously paragraph point 3).*

If present, the central wheels (called **Kicker wheels and supplied in equipment**) serve to turn over and to convey laterally the product of the central zone.

Change of direction

To **change direction** a few meters before the end of the field, the operator shall must lift the mobile chassis from the ground (20" - 24") to carry out the operation safely.



fig.33



fig.34

IMPORTANT

The tractor must be driven in a more or less straight line.

Proceed for several meters and then check the result of the process. Whenever the operator feels that one or more adjustments are required, follow the instructions in the relative paragraphs.

IMPORTANT

Except for cases otherwise specified, all adjustments must be performed with the tractor engine off, the parking brake pulled and the ignition key removed from the dashboard.

After changing direction, the operator can lower the mobile chassis, and eventually the kicker wheel if available, to continue the working process.

Prior to work breaks (even short ones) the operator must always:

- switch off the tractor engine;
- engage the parking brake;
- place the gear lever in neutral position;
- remove the keys from the dashboard.

When the operator has finished work for the day, he must return the rake to its transport configuration before returning the tractor to its parking area.

Rake storage instructions are described in paragraph at page 27.

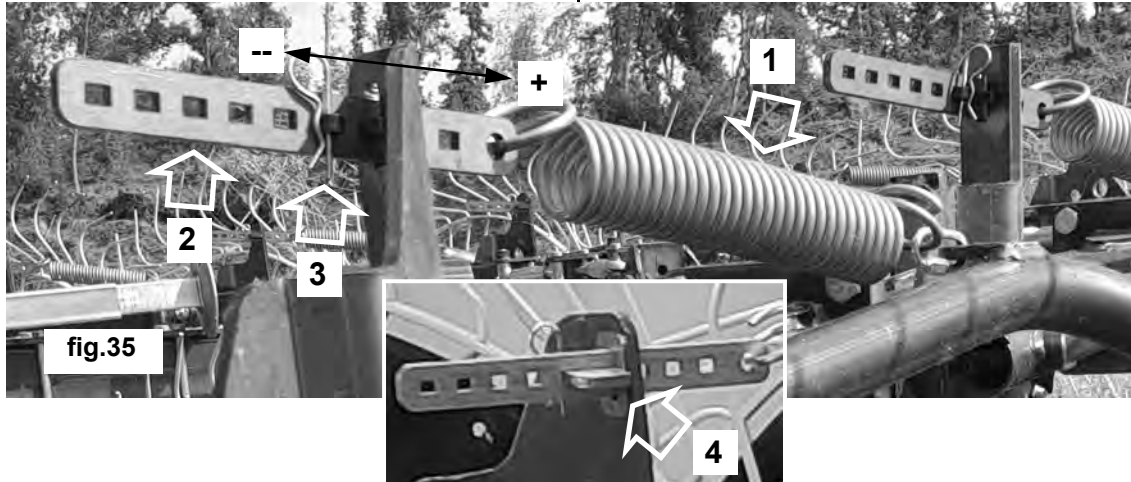

Pressure on ground of the wheels

Fig.35 – Spring (1) and holed plate (2), present on each wheel. The ground pressure of each wheel is provided by the respective spring (1). This pressure determines the positioning of the wheel teeth in relation to the ground. The spring is hooked, on one side, to the wheel arm and, on the other, to the holed plate (see fig.35). Act on the holed plate (2) to adjust the pressure to the wheel.

Pull R cotter pin (3) to unlock the safety lock (4). Pull the lock out of the plate. By pushing the plate into its support, the spring pushes on the arm causing an increase in the ground pressure of its wheel resulting in the lowering of the teeth on the ground. By pulling the plate, instead, the pressure decreases causing the teeth lifting from the ground.

Note: *to have an optimal harvesting, the teeth of each wheel must just touch the ground, an excessive pressure on ground of a wheel causes a considerable scraping of soil by means of teeth and therefore a them quick consumption.*

Once the correct pressure has been determined, insert the safety lock onto the holed plate and lock it with R cotter pin. – apply the same pressure to all the rake wheels.

CHECKS and TASKS					
	first 8 hours	8 hours or daily	50 hours or biweekly	100 hours or monthly	600 hours or yearly
Check screws and nuts tightening	X				
Grease nipples top-up		X			
Check presence and integrity of pins and relative safety pins		X			
Check of parts subject to wear and pressure (tines / wheel tires)			X		
Check screws and nuts tightening			X		
Check for leaks or spillage of hydraulic oil (*)			X		
Check tire wear and pressure				X	
Check entire structure				X	
Check integrity of hydraulic pipes protective sleeves (*)				X	
Check integrity of adhesive labels and pictograms					X

(*) Pay particular attention to the fluid leaks under pressure. Proceed with particular caution, because, the fluid escaping through small invisible holes, can pierce the skin and to cause serious infections. Therefore, use spectacles with side protections and, to found the leaks, a piece of cardboard or wood .



MAINTENANCE

Precautions during maintenance

The hay rake is an agricultural equipment that does not require special maintenance, nor relative programs. However, there is a periodical intervention, described below, which, if done with care by the Customer, will maintain the efficiency and the working capacity of the machinery avoiding any functional damage.

The operator, who must be an adult, qualified and trained to carry out such interventions, must necessarily observe as follows:

- wear **PPE** associates;



HAZARD

- **any type of operation has to be performed on a flat surface, sufficiently illuminated and clear of people, animals or things that might hinder the maneuver. The equipment must be firmly placed on the ground or, if it is hooked to the tractor, with the engine switched off, the parking brake engaged, and the ignition key removed from the dashboard.**

- before operating, for his safety and to prevent damage to the hay rake, he must apply, well in sight on the tractor dashboard, the warning sign "**Machine under Maintenance**";
- both maintenance and repair operations, once started, must always be finished and never postponed;
- he mustn't rely on his memory, but always read the instructions in this manual and execute them accurately;
- the use of equipment to carry out the maintenance tasks is subject to the relative injury legislation. However, do not use the equipment in an improper way, as for example, using gasoline to clean or pliers instead of a wrench;
- only use spare parts that are type approved or recommended by the Manufacturer.

At the end of maintenance tasks or reparations, remove water, oil, grease oily rags, tools or other material that may be present from the area.

Maintenance tasks

The intervention times are for information only and refer to normal conditions of use. Therefore, they are subject to changes in relation to the kind of service, the environment in which the work is done (more or less dusty) seasonal factors etc. The worse the machine's conditions are, the more the interventions must be increased.

Lubrication

To top up the greasers, remove their protection caps (if present), remove all traces of dust and then use the pump to inject the grease. Afterwards, use a cloth to remove any excess grease on the greasers. Use a brush to apply grease wherever there aren't any greasers.

Teeth: if you need to replace one or more of the teeth (being worn or broken), you must remove the respective retainer plate (3). To do this, fully undo the two retainer nuts (2) and the respective screws (4). You can then remove the plate and teeth.

Put in the new teeth, reinstall the plate, then do up the two retainer screws and respective nuts.

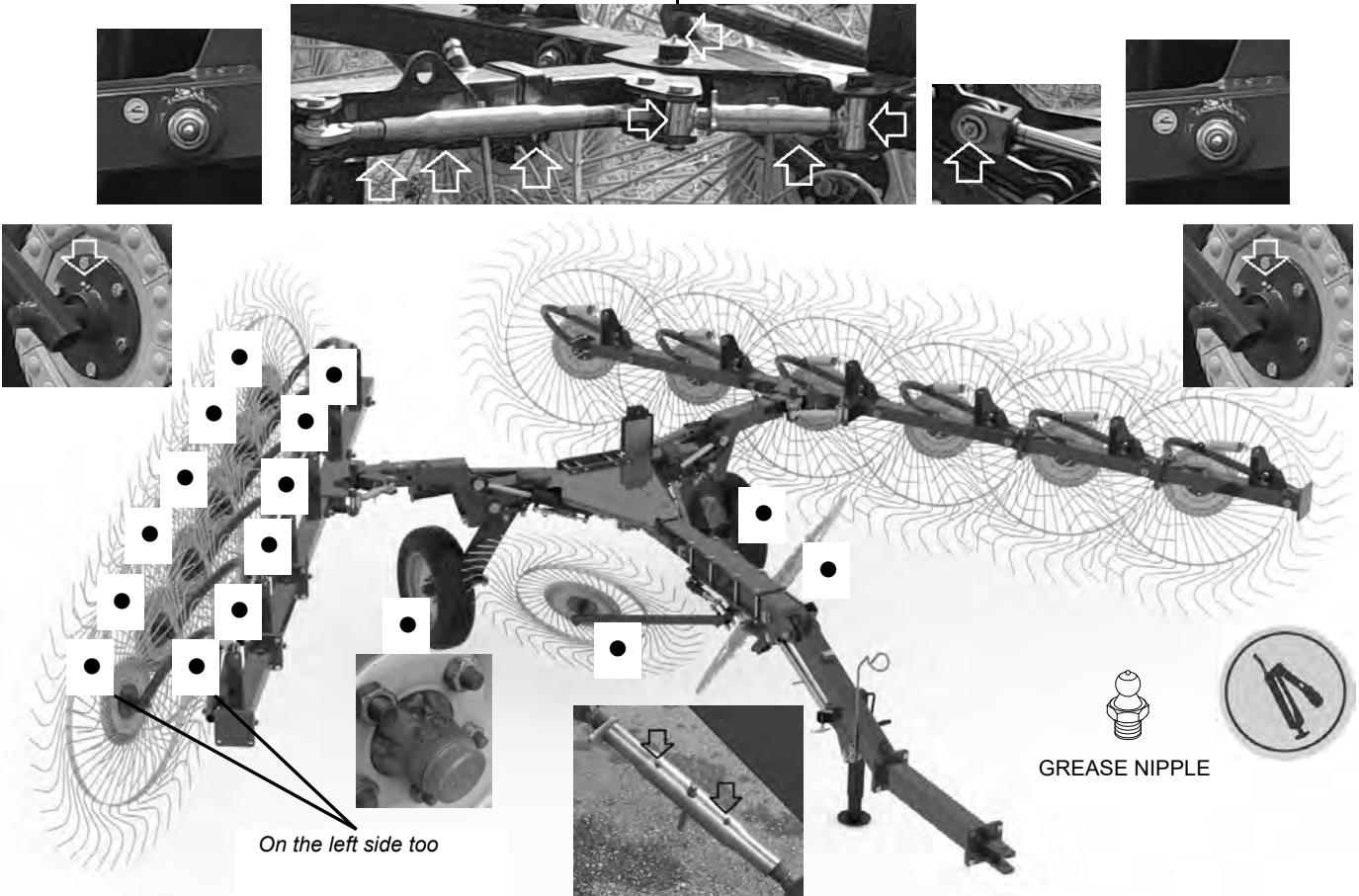

fig.39

All grease top-up points on the rake are indicated by labels like the one shown in the fig.39.

IMPORTANT
To avoid pollution, it is strictly forbidden to dispose of oil, lubricants, filter cartridges or other noxious materials in the environment. Comply with all regulations in force on disposal of liquid and solid substances.



Replacing a wheel and/ or its teeth

Wheel: If you need to replace a wheel, fully undo the six retainer nuts (1), undo the respective screws (5) and remove the wheel from its coupling (or hub).

Put on a new wheel, do up the six screws and then also the respective nuts.

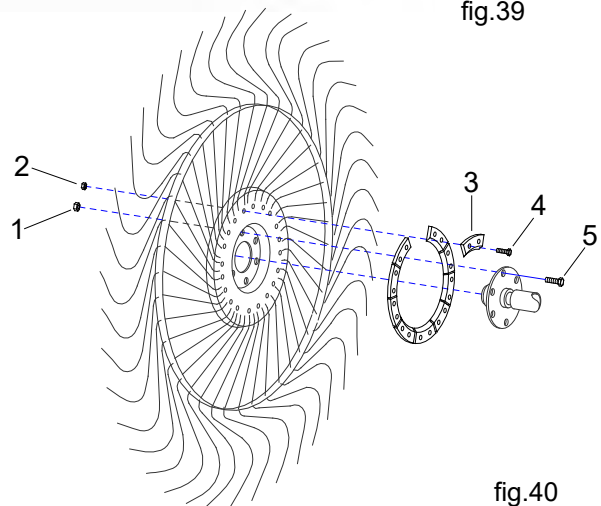

fig.40

Tires

Maximum pressure: **3 bar (43.5 PSI)**



Maximum operating pressure: 2 ÷ 2.5 bar (29 ÷ 36 PSI).

 **HAZARD**

Avoid excessive inflation pressure because it could cause the tires to explode.

Troubleshooting

CAUSE

FAILURE	CAUSE	SOLUTION
The cylinder activation control does not respond	Hydraulic oil level low Hydraulic system piping is damaged Hydraulic pump is damaged Filter is clogged	Top up oil level Replace piping Replace pump Replace filter
The cylinders only move intermittently	Air in the hydraulic circuit	Operate the pump at no load for a few minutes, using the jacks, to expel any air in the hydraulic circuit
The cylinders move even when the command is not given	Cylinder seals are worn out	Replace seals
Overheated oil	Filter is clogged Pipes are crushed Oil level low	Replace filter Check and replace Pipes Top up oil level
Oil loss	Slow connection Worn out seal	Squeeze the pipe Replace the seal

Material disposal in case of demolition

When the hay rake is out of service, the parts that may become dangerous for people, animals and the environment if dispersed must become innocuous. The constituent materials of the equipment, which are subject to a separate disposal are:

- **iron**
- **lubricant oil**
- **rubber**

Disposal of these materials must be done according to the regulations of applicable law, in force in each individual Country.

Page left blank intentionally



Power Rake

PR 8, PR 10, PR 12

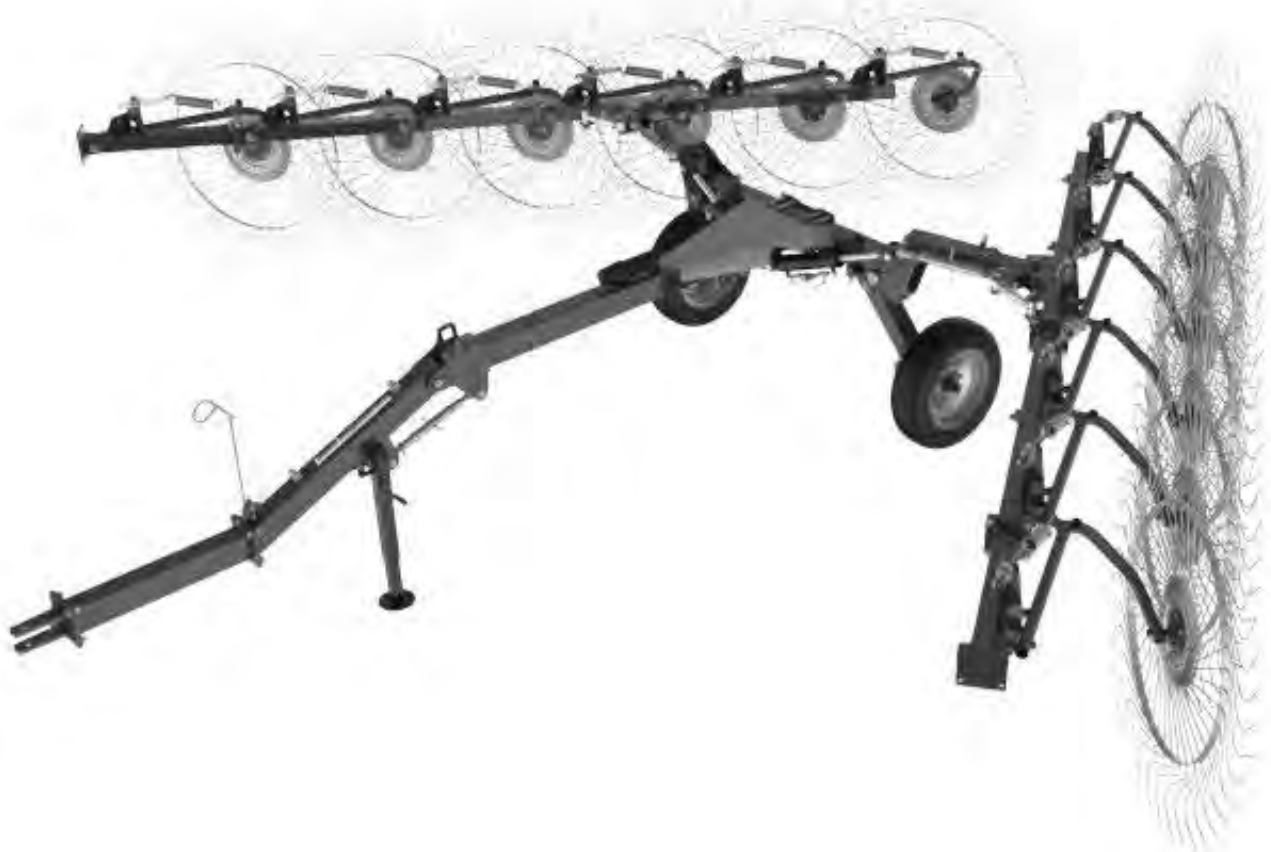

Parts Manual
Issue 1a (05/12/2025)

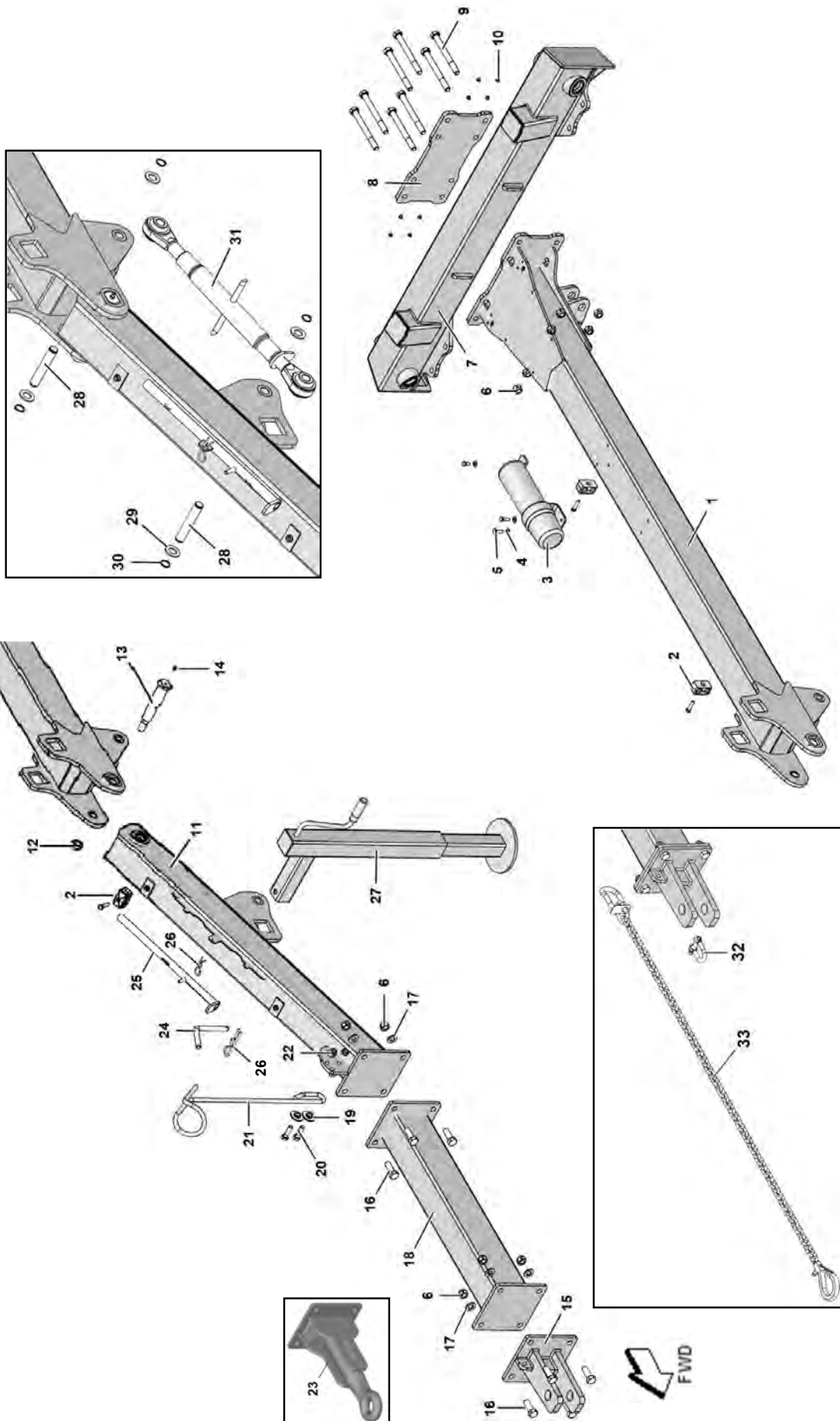



Item	Part #	Description
1	DC00000538	PR RUDDER
2	18033342	CF2 COLLAR
3	9080022	MANUAL HOLDER
4	3030156	WASHER M8 ZN
5	3011242	HH SCREW M8x25 ZN
6	3020204	SELF LOCKING NUT M16
7	DC00000532	PR CROSSBAR
8	DV00000006	RUDDER FIXING PLATE
9	3010309	HH SCREW M16X160 ZN
10	9190031	PLASTIC CAP - Ø7,2
11	DC00000539	PR FRONT RUDDER
12	3020216	SELF LOCKING NUT M20
13	CM02002029	FLANGED PIN - Ø30x187
14	3090101	GREASE NIPPLE M8X1
15	G014000006	USA TOWING HITCH
16	3011645	HH SCREW M16X45 ZN
17	3030175	WASHER M16 ZN
18	DC00000540	RUDDER EXTENSION - PR 12
19	18033240	WASHER FOR SPRING
20	3011208	HH SCREW M12X40 ZN
21	18037319	support for hydraulic piping
22	3020202	SELF LOCKING NUT M12
23	18032759	TOWING HITCH
24	18033195	SAFETY PIN
25	DC00000666	LEVER FOR TIE ROD
26	3040201	R COTTER PIN Ø3X60
27	18036279	BEARING FOOT
28	CM02002030	RUDDER TIE ROD PIN
29	3030163	WASHER M18 ZN
30	3120158	SEEGER
31	12071324	ADJUSTABLE TIE ROD ZN Ø19
32	3160103	u SHACKLE
33	3150117	USA TOWING CHAIN

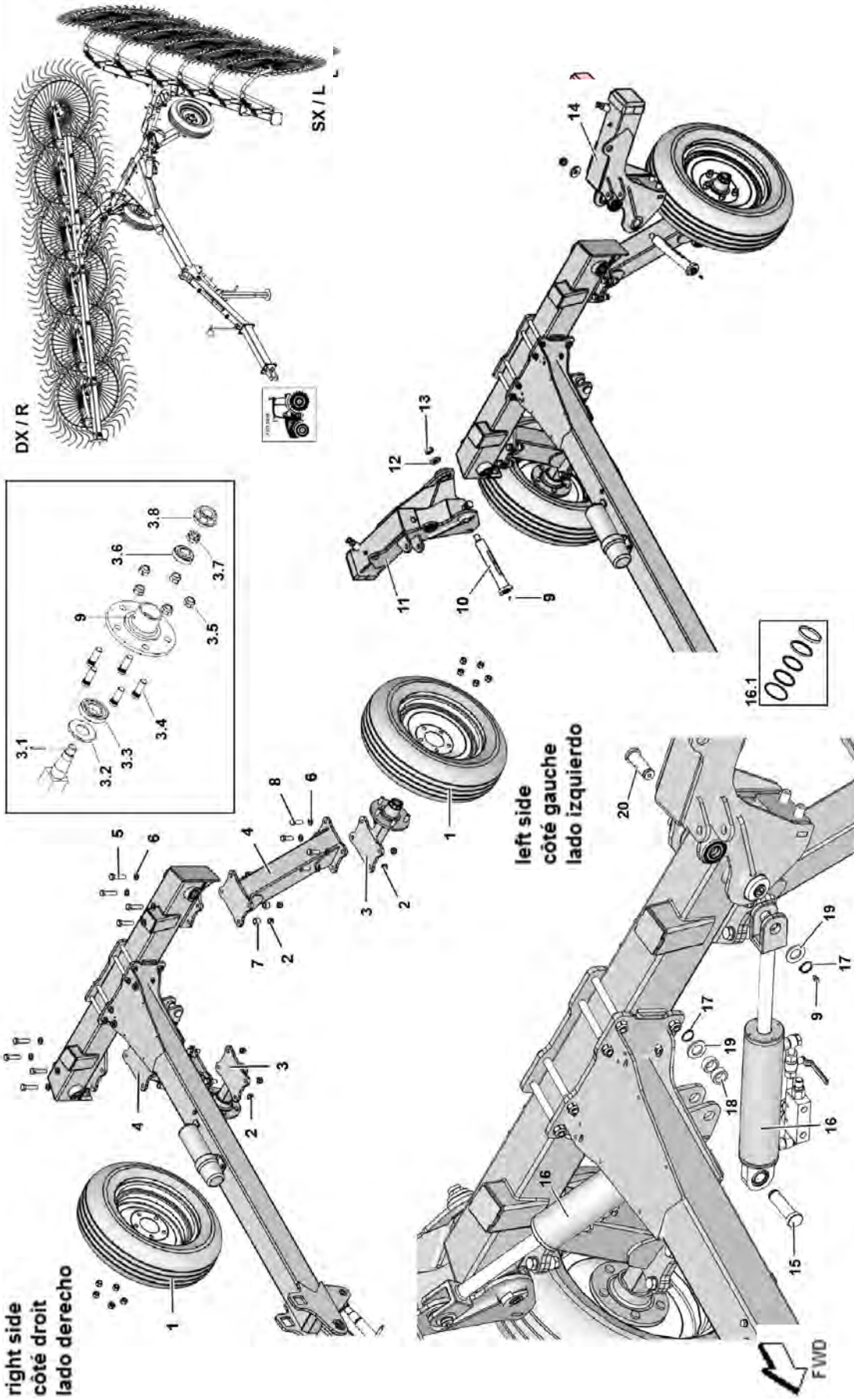



Item	Part #	Description
1	CP00000001	COMPLETE WHEEL 195/65 R15
1.1	12170108	WHEEL - P205/70 R15
2	3020204	SELF LOCKING NUT M16
3	DC00000534	FLANGED HUB
3.1	3040114	SPLIT PIN 4X35
3.2	12360002	DUST COVER 35X72x1,5
3.3	12240143	BEARING 30207
3.4	3011609	STUD BOLT MB16
3.5	3020218	NUT 16MB
3.6	12240119	BEARING 30205
3.7	3020241	SELF LOCKING NUT 20MB
3.8	12360003	DUST COVER CAP Ø52
4	DC00000533	PR LEG
5	3011316	HH SCREW M16X65 ZN
6	3030175	WASHER M16 ZN
7	18032428	SPACER 28X17X20
8	3011645	HH SCREW M16X45 ZN
9	3090101	GREASE NIPPLE M8X1
10	DC00000541	PR R TELESCOPIC CHASSIS PIN
11	DC00000536	PR R TELESCOPIC CHASSIS
12	18032388	WASHER 50X20X8
13	3020216	SELF LOCKING NUT M20
14	DC00000535	PR L TELESCOPIC CHASSIS
15	18035588	HYDRAULIC CYLINDER PIN
16	DI01000059	PR OPENING HYDRAULIC CYLINDER
16.1	10010760	SEAL KIT FOR CYLINDER
17	3120127	SEEGER Ø25E
18	DTT0100132	SPACER 33.7X26
19	3030198	WASHER M24 ZN
20	CM02002037	PIN Ø25X75

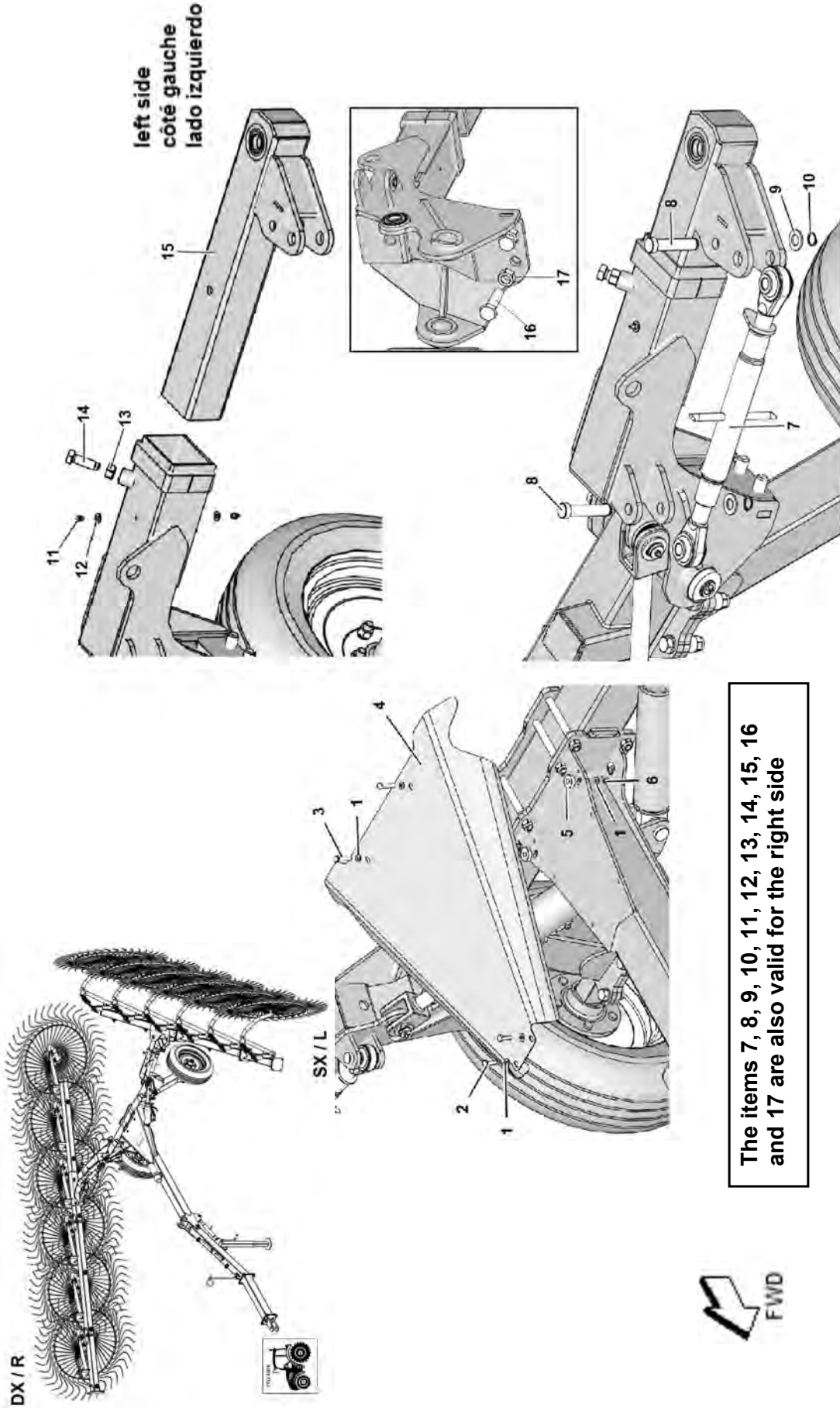

The items 7, 8, 9, 10, 11, 12, 13, 14, 15, 16 and 17 are also valid for the right side





Item	Part #	Description
1	3030156	WASHER M8 G
2	3011242	HH SCREW M8x25 G
3	3011252	HH SCREW M8x35 G
4	DLD0102511	PR CARTER
5	18033585	NYLON SPACER - 30X10,5X9
6	3020209	SELF LOCKING NUT M8
7	12071324	ADJUSTABLE TIE ROD ZN Ø19
8	CM02002033	PR TELESCOPIC CHASSIS PIN
9	3030163	WASHER M18 G
10	3120158	SEEGER Ø19E
11	3090101	GREASE NIPPLE M8X1
12	3030156	WASHER M8 G
13	3020339	NUT M16 G
14	18032181	HH SCREW M16X50 G
15	DC00000537	TELESCOPIC ARM
16	3011652	HH SCREW M20X90 G
17	3020336	NUT M20 G

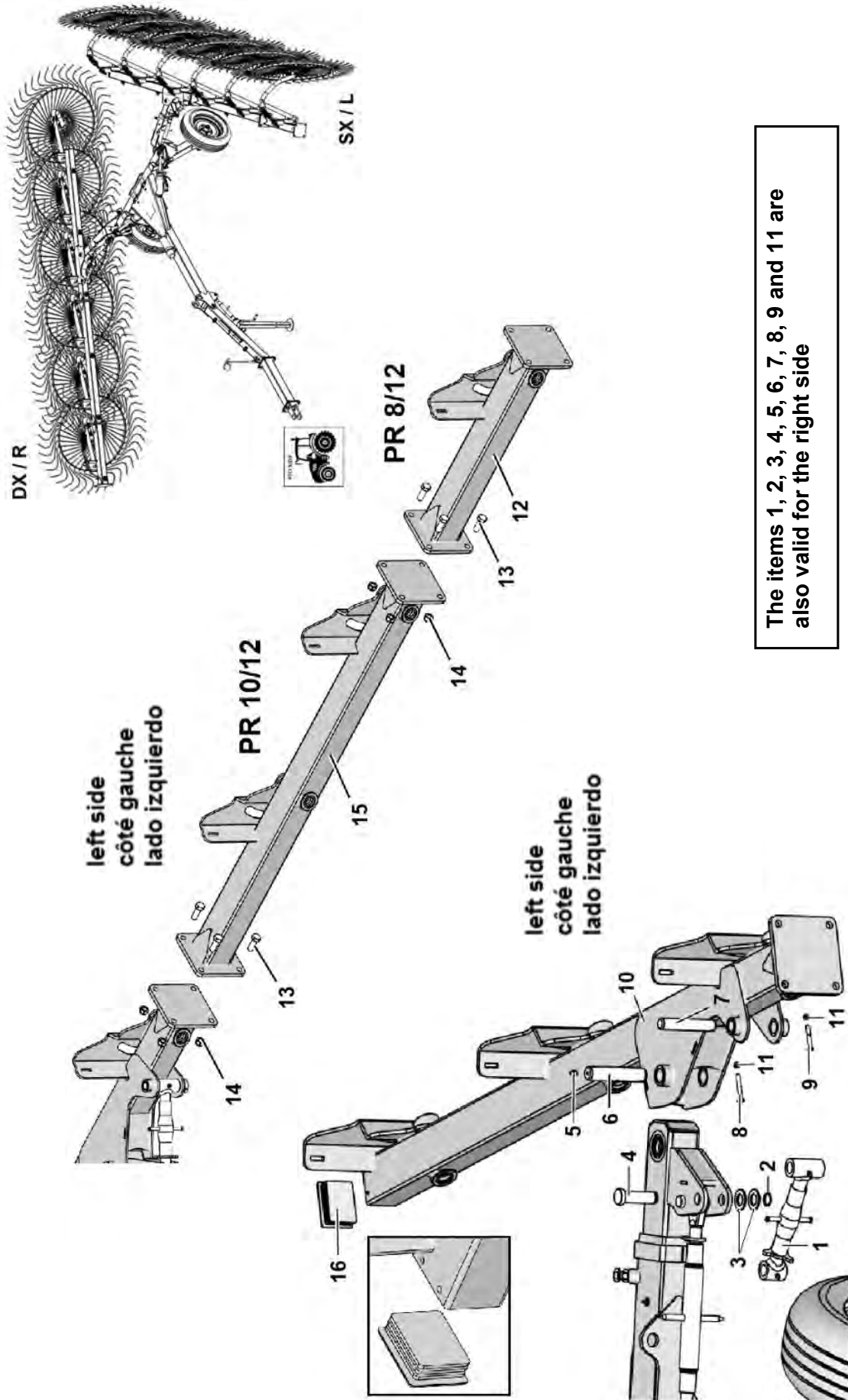



Item	Part #	Description
1	18037050	ADJUSTABLE TIE ROD UNIT
2	3120127	SEEGER Ø25E
3	3030198	WASHER M24 ZN
4	18035588	HYDRAULIC CYLINDER PIN
5	3090101	GREASE NIPPLE M8X1
6	18032906	PIN - Ø30x148 ZN
7	CM02002031	PIN – Ø25x142 ZN
8	3010781	HH SCREW M8x55 ZN
9	3011210	HH SCREW M8x50 ZN
10	DC00000542	L CHASSIS WITH JOINT
.		R CHASSIS WITH JOINT
11	3020209	SELF LOCKING NUT M8
12	DC00000544	PR L EXTENSION - PR 8 / 12
		PR R EXTENSION - PR 8 / 12
13	3011645	HH SCREW M16X45 ZN
14	3020204	SELF LOCKING NUT M16
15	DC00000679	PR L EXTENSION - PR 10 / 12
.		PR R EXTENSION - PR 10 / 12
16	9190023	RECTANGULAR CAP

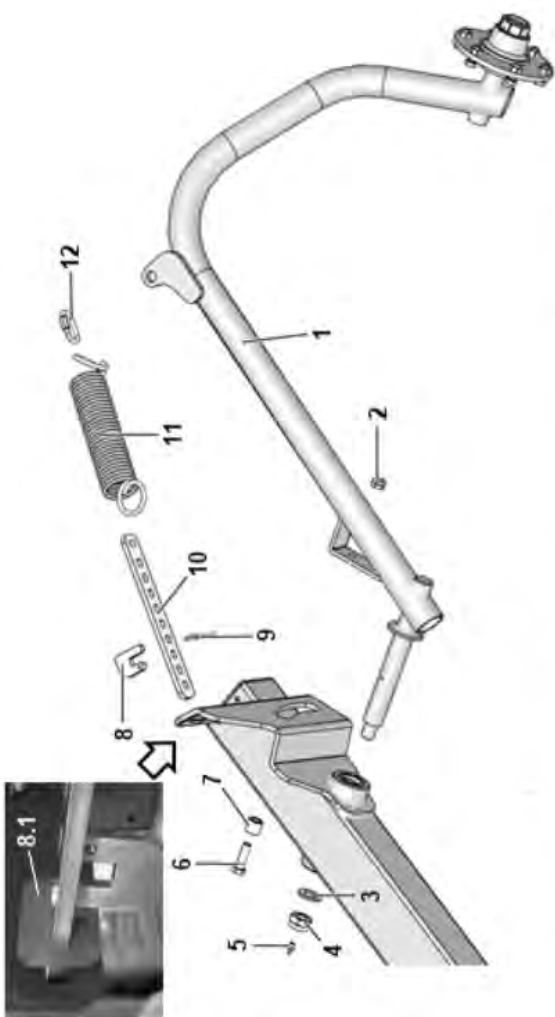
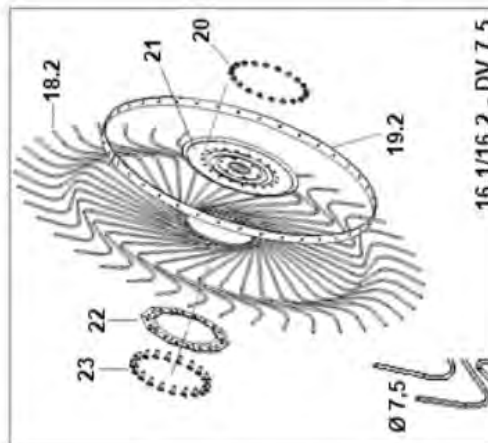
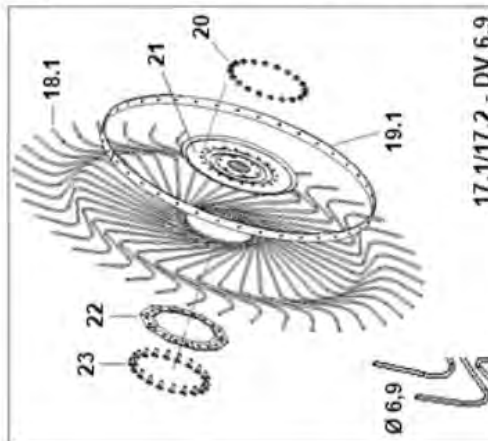
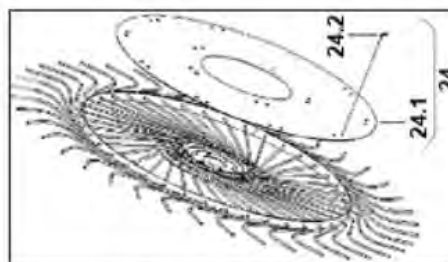
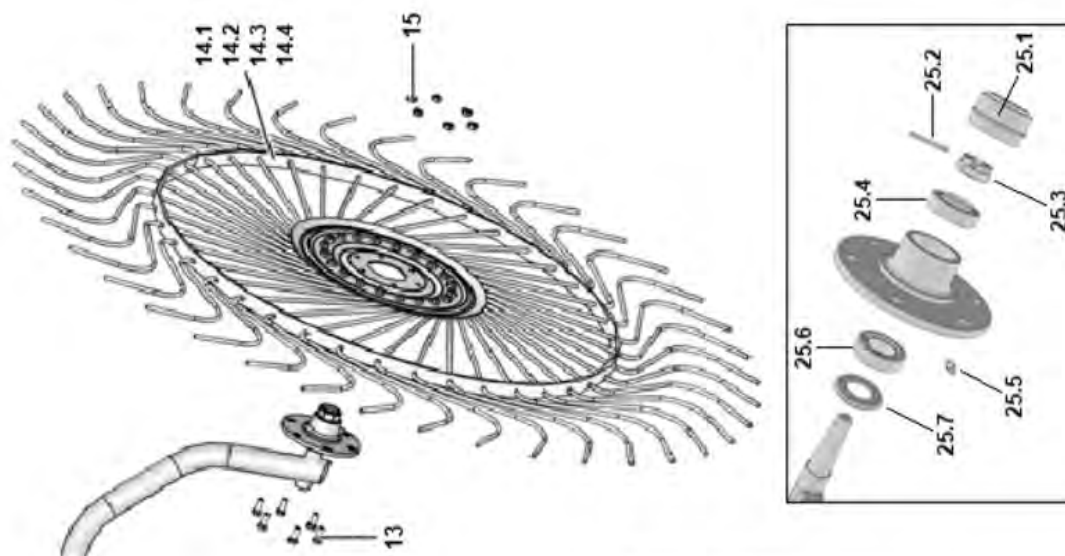



Item	Part #	Description
1	DC00000547	PR L ARM
2	3020202	SELF LOCKING NUT M12
3	3030168	WASHER M20 ZN
4	3020216	SELF LOCKING NUT M20
5	3090101	GREASE NIPPLE M8X1
6	3011208	HH SCREW M12X40 ZN
7	18032424	SPACER - Ø22-Ø12,5-20
8	DLD0103252	MECHANICAL STOP FOR SPRING ADJUSTING PLATE
8.1	DLD0500005	STOP PLATE
9	3040201	R COTTER PIN - Ø3X60 ZN
10	DLD0103251	SPRING ADJUSTING PLATE
11	11010508	WHEEL RETURN SPRING
12	CM00200002	JUNCTION RING - Ø6x58X27
13	3011211	HH SCREW M10X25 ZN
14.1	18036078	RIGHT VICON Ø 6,9 RAKE WHEEL
14.2	18036079	LEFT VICON Ø 6,9 RAKE WHEEL
14.3.	18036082	RIGHT HSI Ø 7,5 RAKE WHEEL
14.4	18036083	LEFT HSI Ø 7,5 RAKE WHEEL
15	3020328	NUT M10
16.1	18036078	RIGHT VICON Ø 6,9 RAKE WHEEL
16.2	18036079	LEFT VICON Ø 6,9 RAKE WHEEL
17.1	18036082	RIGHT HSI Ø 7,5 RAKE WHEEL
17.2	18036083	LEFT HSI Ø 7,5 RAKE WHEEL
18.1	18030415	VICON TOOTH Ø 6,9
18.2	18034061	HSI TOOTH Ø 7,5
19.1	18031113	EXTERNAL RAKING WHEEL RING
19.2	18032202	EXTERNAL RAKING WHEEL RING
20	3020224	SELF LOCKING NUT 10MA CONELOX
21	18032928	RAKING WHEEL FLANGE
22	18030416	TEETH FASTENER PLATE
23	3010105	SCREW T.T.Q.S.T. M10X25 ZN

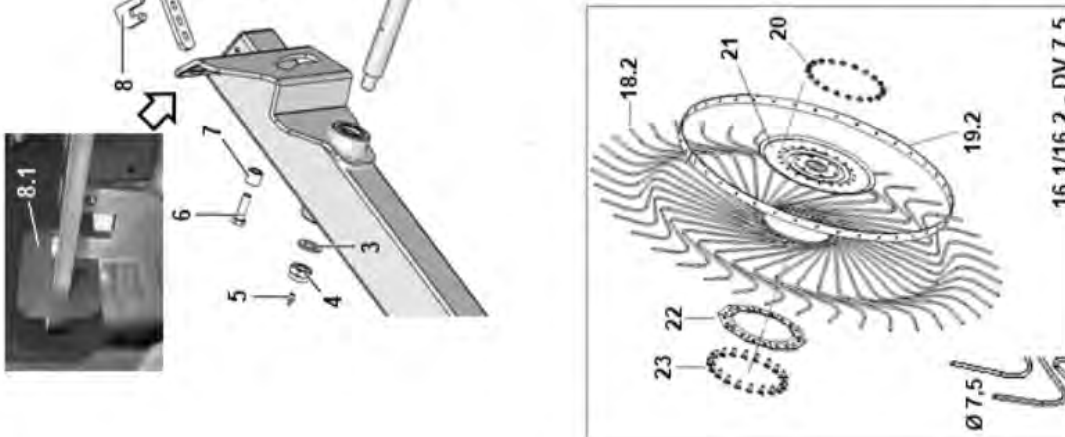
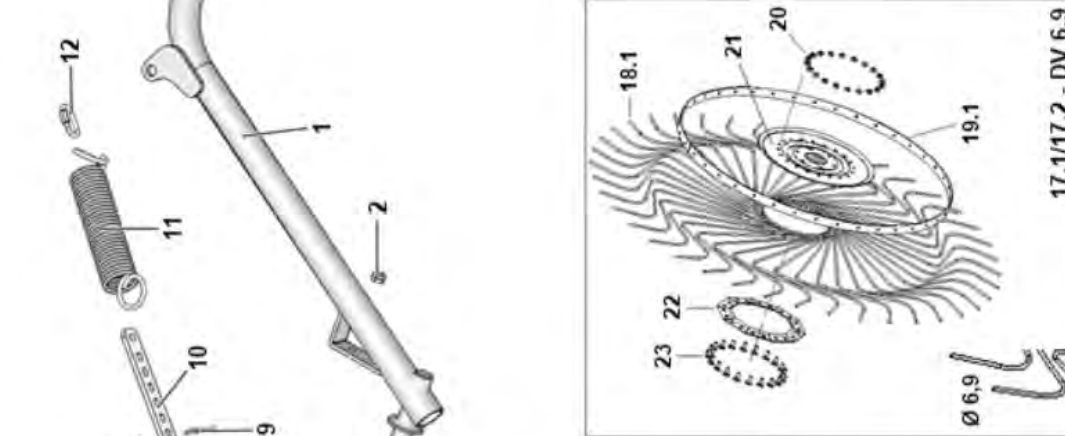
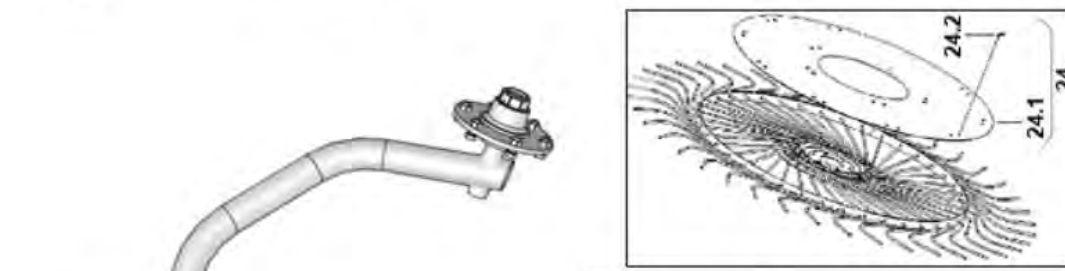
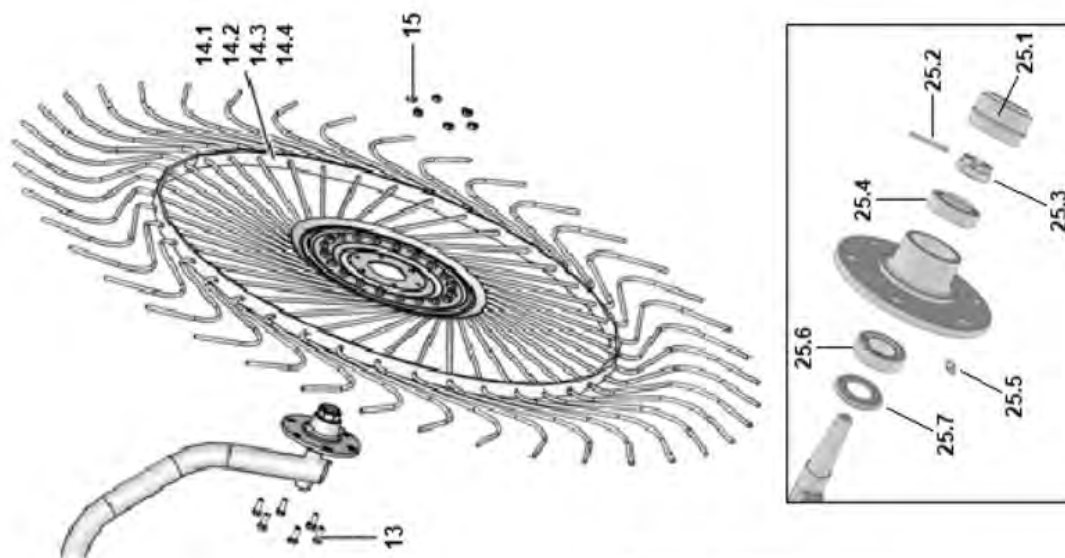



Item	Part #	Description
24	18032659 (*)	COMPLETE WIND GARD
24.1	9300002 (*)	WIND GARD
24.2	4010707 (*)	BAND PLASTIC
25.1	12360001	DUST COVER CUP
25.2	3040114	SPRING 4X35
25.3	3020210	SELF LOCKING NUT 18MB
25.4	12240118	BEARING 30204
25.5	3090101	GREASE ZERK 8x1
25.6	12240119	BEARING 30205
25.7	12860001	DUST COVER 25X52x2

(*) : ON DEMAND - SUR DEMANDE - A PETICIÓN

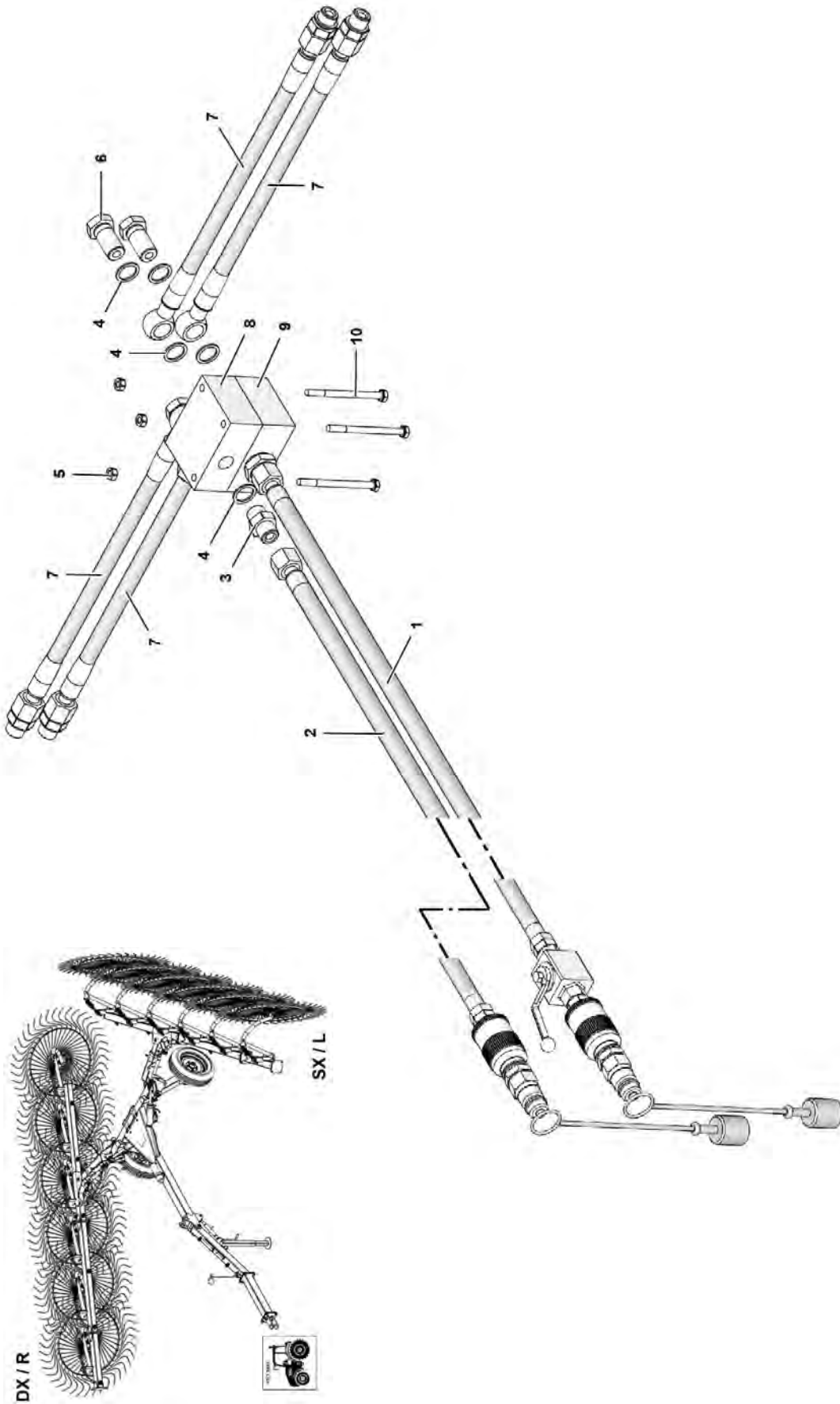



Item	Part #	Description
1	DATT000089	OIL OUTLET PIPING
2	DATT000088	OIL INTLET PIPING + TAB
3	4010207	NIPPLE MM 3/8"
4	3030403	COPPER WASHER 3/8"
5	3020308	NUT - M6
6	3011605	HOLED SCREW - 0,375G
7	DATT000090	PIPING + FITTING + WASHER
8	4020145	2-WAY FLOW DIVIDER
9	4020144	THREE-WAY BLOCK
10	3011647	HH BOLT - M6X80 G

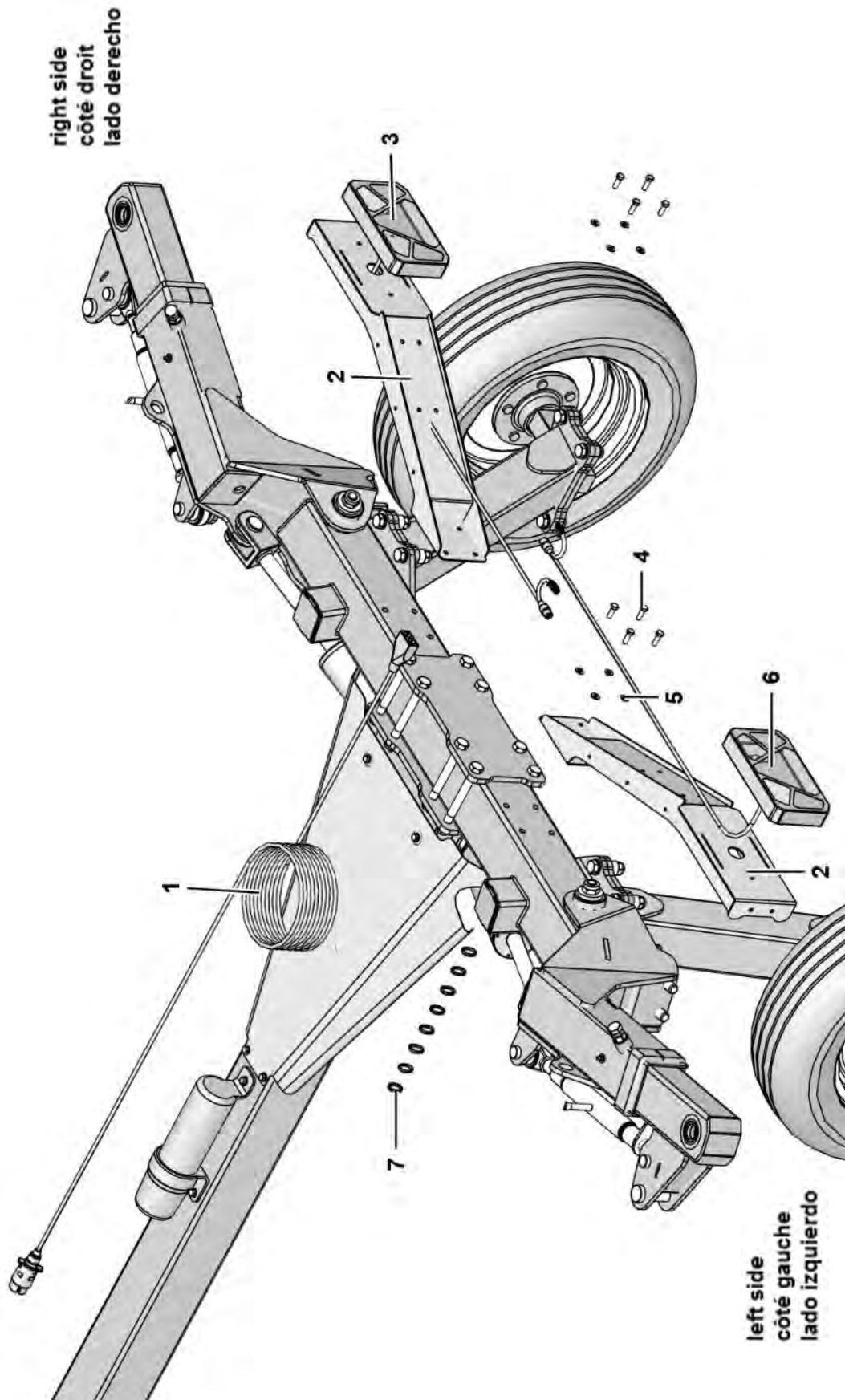



Item	Part #	Description
1	7010855 (*)	ELECTRICAL CABLE – MT 7
2	DC00000550 (*)	PR LIGH SUPPORT
3	7270032 (*)	R REAR LED LIGHTING DEVICE
4	3011242 (*)	HH SCREW M8X25 ZN
5	3030156 (*)	WASHER M8 ZN
6	7270033 (*)	L REAR LED LIGHTING DEVICE
7	4010707 (*)	PLASTIC TIE

KICKER WHEEL

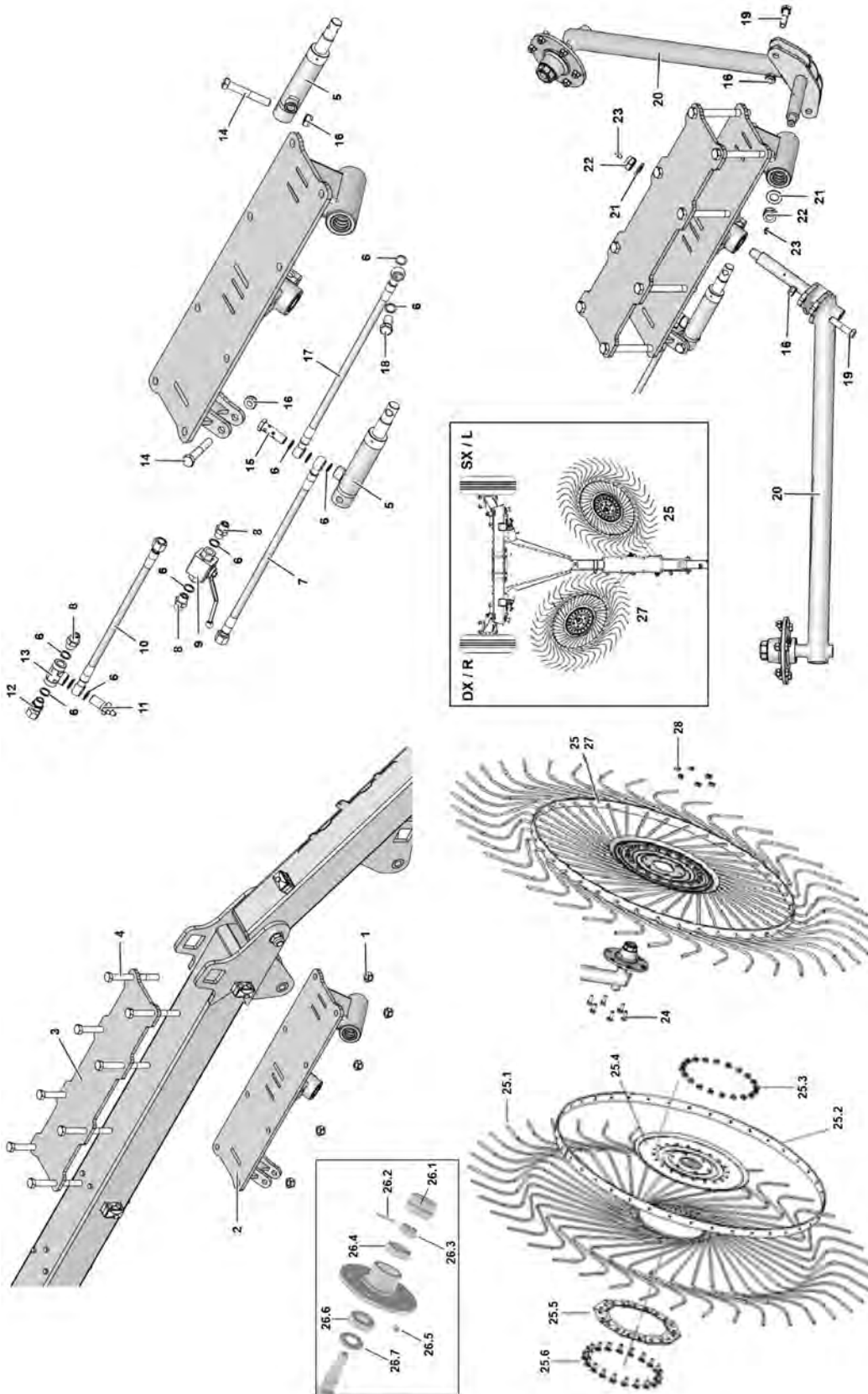



Item	Part #	Description
1	3020204 (*)	SELF LOCKING NUT M16
2	DC00000548 (*)	ARM HOLDER PLATE
3	DLD0102522 (*)	PR KW FIXING PLATE
4	3010309 (*)	HH SCREW M60X160 ZN
5	18032613 (*)	SIMPLE-ACTING HYDRAULIC CYLINDER
6	3030413 (*)	BONDED WASHER – 0,375G
7	DATN000193 (*)	HYDRAULIC PIPING – 2SC 5/16" FD-O-3/8 L.480
8	4010207 (*)	M/M FITTING – 0,375G
9	4021501 (*)	2-WAY TAP – 0,375G
10	DATN000192 (*)	HYDRAULIC PIPING – 2SC 5/16" FD-O-3/8 L.400
11	4021503 (*)	CHOKE SCREW 0,375G
12	4010946 (*)	SWIVEL REDUCTION - F 3/8" - M 3/8"
13	4010938 (*)	3-WAY FITTING – 0,375G
14	3010249 (*)	HH BOLT- M14X90 G
15	4021509 (*)	DOUBLE HOLED SCREW - 0,375G
16	3020203 (*)	SELF LOCKING NUT M14
17	DATN000194 (*)	HYDRAULIC PIPING – 2SC 5/16" 3/8-O-3/8 L.480
18	3011605 (*)	HOLED SCREW - 0,375G
19	3011202 (*)	HH SCREW M14X60 ZN
20	DC00000549 (*)	PR ARM
21	3030168(*)	WASHER M20 ZN
22	3020216 (*)	SELF LOCKING NUT M20
23	3090101 (*)	GREASE NIPPLE M8X1
24	3011209 (*)	HH BOLT- M10X25 G
25	18036127 (*)	R RAKE WHEEL
25.1	18031810 (*)	TOOTH "KEP 110"
25.2	18031809 (*)	RAKING WHEEL RING KEP
25.3	3020224 (*)	SELF LOCKING NUT M10 CONELOX

KICKER WHEEL

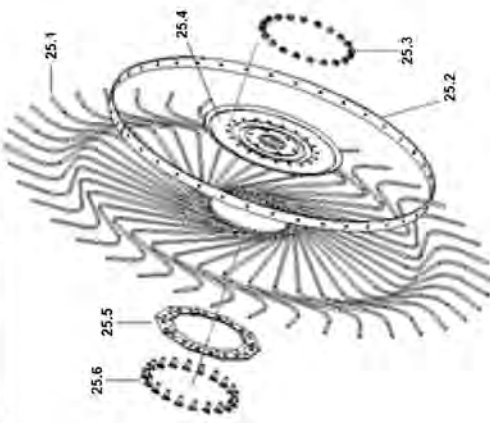
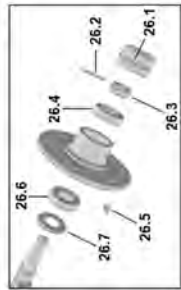
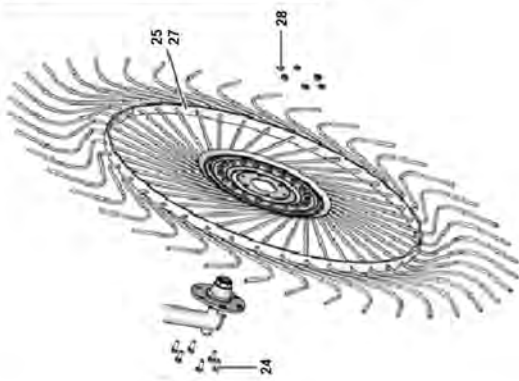
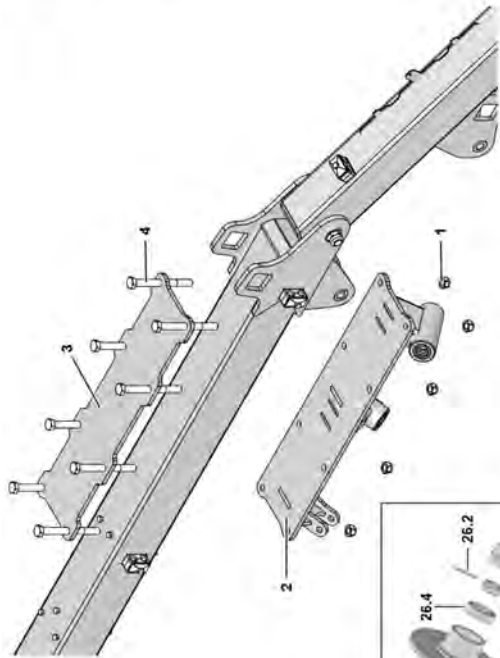
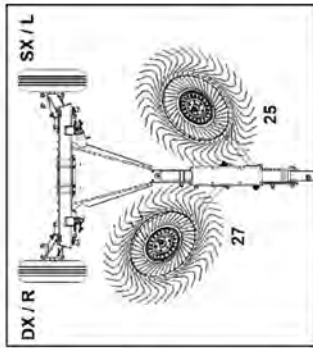
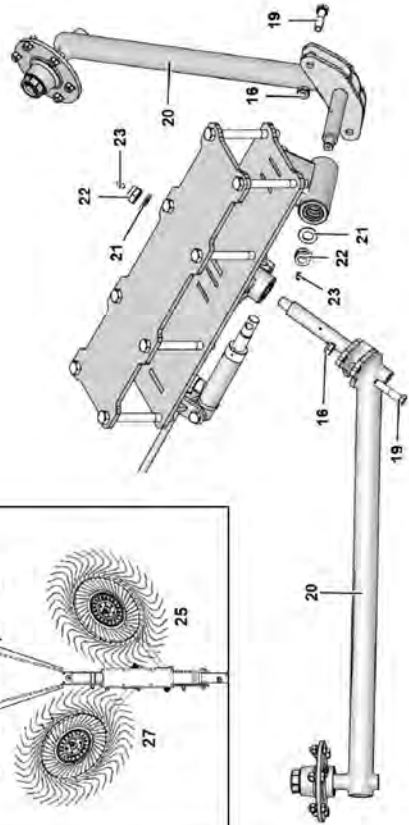
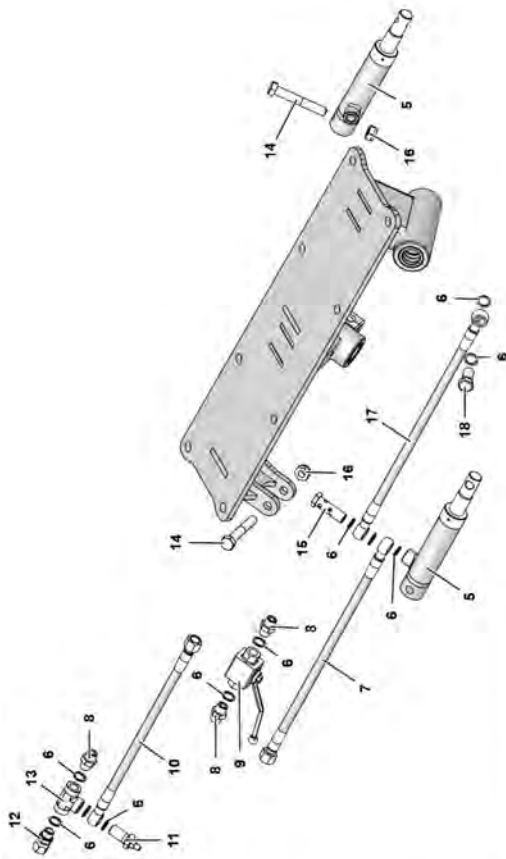



Item	Part #	Description
25.4	18032928 (*)	RAKING WHEEL FLANGE
25.5	18030416 (*)	TEETH FASTENER PLATE
25.6	3010105 (*)	SCREW TTQS M10X25
26.1	12360001 (*)	DUST COVER CUP
26.2	3040114 (*)	SPRING 4X35
26.3	3020210 (*)	SELF LOCKING NUT 18MB
26.4	12240118 (*)	BEARING 30204
26.5	3090101 (*)	GREASE ZERK 8x1
26.6	12240119 (*)	BEARING 30205
26.7	12860001 (*)	DUST COVER 25X52x2
27	18036095 (*)	L RAKE WHEEL
28	3020328 (*)	NUT M10



401 Jeffreys Road
Rocky Mount, NC 27804
www.tarrivermfg.com

Tel: 252-822-7140
Fax: 252-787-5855
Sales@tarrivermfg.com