

# **GREENSCAPE 560**

## **Minimum Till Drill**

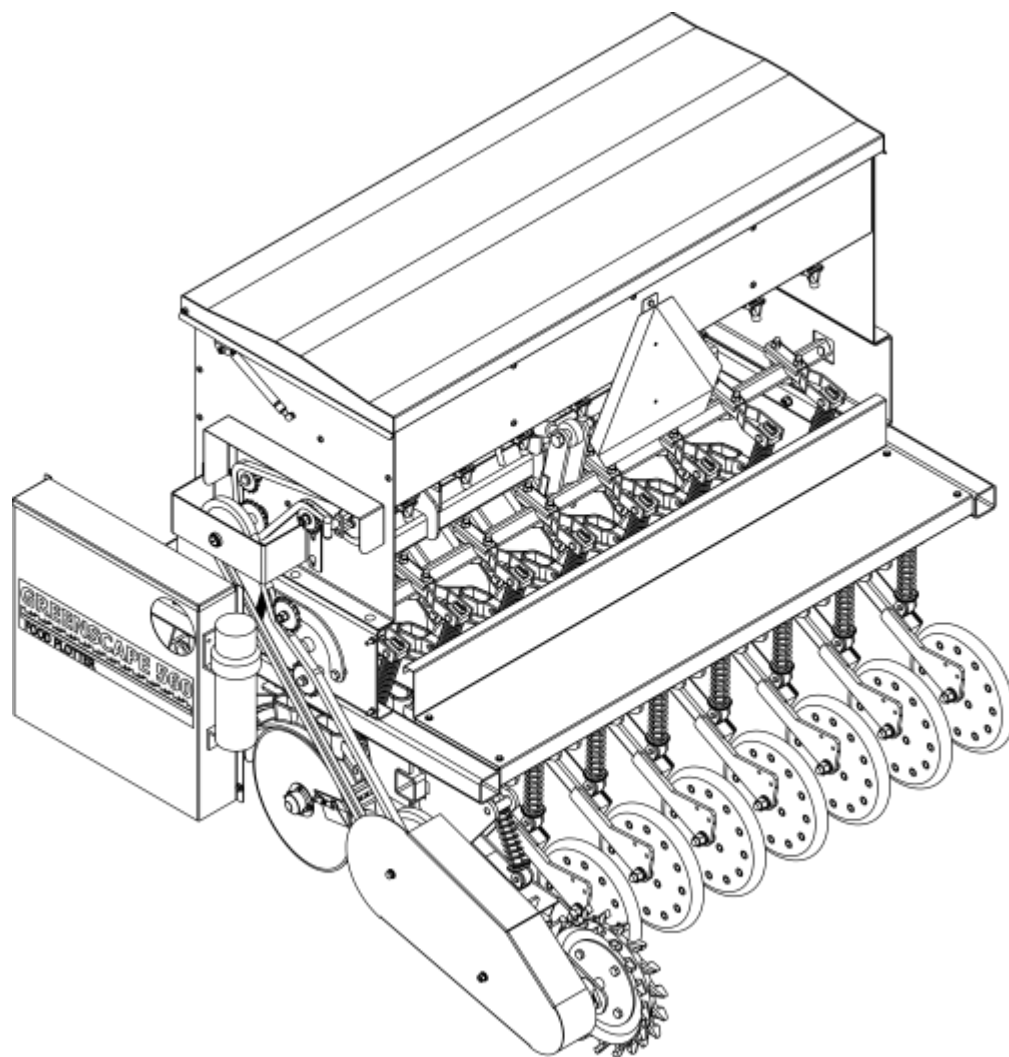

## **Operator's Manual**

**Page left blank intentionally**

**TO THE DEALER:**

Assembly and proper installation of this product is the responsibility of the Belco Resources dealer. Read manual instructions and safety rules. Make sure all items on the Dealer's Pre-Delivery and Delivery Check Lists in the Owner's/Operator's Manual are completed before releasing equipment to the owner.

**TO THE OWNER:**

Read this manual before operating your Belco Resources equipment. The information presented will prepare you to do a better and safer job. Keep this manual handy for ready reference. Require all operators to read this manual carefully and become acquainted with all the adjustment and operating procedures before attempting to operate. Replacement manuals can be obtained from your selling dealer. The equipment you have purchased has been carefully engineered and manufactured to provide dependable and satisfactory use. Like all mechanical products, it will require cleaning and upkeep. Lubricate the machine as specified. Observe all safety information in this manual and safety decals on the equipment. For service, your authorized Belco Resources dealer has trained mechanics, genuine Belco Resources service parts, and the necessary tools and equipment to handle all your needs. Use only genuine Belco Resources service parts. Substitute parts will void the warranty and may not meet standards required for safe and satisfactory operation.

Record your implement model and serial number in the space provide below. Your dealer will need this information to give you prompt, efficient service.

**Model Number:** \_\_\_\_\_

**Serial Number:** \_\_\_\_\_

**Date Purchased:** \_\_\_\_\_

# Table of Contents

Introduction .....	5
Technical Specifications .....	5
Safety .....	6
Safety Signal Words .....	6
General Safety Guidelines .....	7
Safety Decal Care .....	7
Before Operation .....	8
During Operation .....	9
Highway And Transport Operations .....	10-11
Attaching to Tractor.....	12
Chain Routing.....	13
Seed Rate Adjustment.....	14
Setting Application Charts.....	15
Calibration Charts.....	16-17
Lubrication and Maintenance .....	18
Torque Specifications .....	19
Parts Breakdown .....	21-41
Warranty .....	42

# Introduction

Thank you for purchasing your Greenscape 560. This model utilizes heavy spring loaded press wheels to precisely follow the ground splitting coulters and double disc assemblies ensuring excellent seed to ground contact for superb germination.

The Greenscape 560 comes with 7 rows of coulters and double disc openers. These seeders can seed corn, beans, oats, wheat, etc.

## Technical Specifications

- Suitable for drilling and fertilizing corn, beans, oats, etc. in level or gently rolling fields.
- Spring load coulters to increase seed/ground contact.
- The double disc coulters create an opening to fertilize and seed easily in tilled soil.
- The depth of seeding can be adjusted. Seeding quantity can be adjusted.
- The seeder can plant seeds, fertilize roll and drag all at the same time.
- Three Point Hitch Cat. 1&2
- Heavy tubular frame construction
- All ground driven, no PTO shaft or gear-box to maintain
- Precise seed metering cups with individual clean out gates
- Rear roller packer rings to firm and smooth seedbed
- Water tight seed box with agitator shaft -calibration chart and seeding rate chart
- 7 Cast Iron double disc openers spaced at 7.5"

	<b>Greenscape 560</b>
Hitch	Cat. 1 & 2
Req. HP	25HP
Working width	60"
Weight	1,028 lbs.
Overall width	68"
Overall height	56"
Overall length	57"
Double disc openers	8
Disc spacing	7.5"
Large seed box capacity	7.6 cu. ft.
Small seed box capacity	2.75 cu. ft.

# Important Safety Information

## Safety

It is important that you read the entire manual and to become familiar with this product before you begin using it. This product is designed for certain applications only. The manufacturer cannot be responsible for issues arising from modification. We strongly recommend this product not be modified and /or used for any application other than that for which it is designed. If you have any questions relative to a particular application, DO NOT use the product until you have first contacted us to determine if it can or should be performed on the product.

Read and understand this manual and all safety signs before operating and maintaining . Review the safety instructions and precautions annually.

## Safety Signal Words

**TAKE NOTE! This safety alert symbol found though out this manual is used to call you attention to instructions involving you personal safety and the safety of others. Failure to follow these instructions can result in injury or death.**



**This symbol means:  
Attention!  
Become alert!  
Your safety is involved!**

Note the use of the signal words, DANGER, WARNING and CAUTION with the safety messages. The appropriate signal word for each has been selected using the following guidelines:



**DANGER:** Indicates an imminently hazardous situation that, if not avoided, will result in death or serious injury. This signal word is to be limited to the most extreme situations typically for machine components which, for functional purposes, cannot be guarded.



**WARNING:** Indicates a potentially hazardous situation that, if not avoided, could result in death or serious injury, and includes hazards that are exposed when guards are removed. It may also be used to alert against unsafe practices.



**CAUTION:** Indicates a potentially hazardous situation that, if not avoided, may result in minor or moderate injury. It may also be used to alert against unsafe practices.

# Important Safety Information

## General Safety Guidelines

Safety of the operator is one of the main concerns in designing and developing a new piece of equipment. Designers and manufacturers build in as many safety features as possible. However, every year many accidents occur which could have been avoided by a few seconds of thought and a more careful approach to handling equipment. You, the operator, can avoid many accidents by observing the following precautions in this section. To avoid personal injury, study the following precautions and insist those working with you, or for you, follow them.

Replace any DANGER, WARNING, CAUTION or instruction safety decal that is not readable or is missing. Location of such decals are indicated in this manual. Do not attempt to operate this equipment under the influence of drugs or alcohol.

Review the safety instructions with all users annually.

This equipment is dangerous to children and persons unfamiliar with its operation. The operator should be a responsible adult familiar with farm machinery and trained in this equipment's operations. **Do not allow persons to operate or assemble this machine until they have read this manual and have developed a thorough understanding of the safety precautions and of how it works.**

To prevent injury of death, use a tractor equipped with a Roll Over Protection System (ROPS). Do not paint over, remove or deface any signs or warning decals on your equipment. Observe all safety signs and practice the instructions on them.

Never exceed the limits of a piece of machinery. If its ability to do a job, or to do so safely, is in question - **Don't try it!**



## Safety Decal Care

- Keep safety signs clean and legible at all times.
- Replace safety signs that are missing or have become illegible.
- Replaced parts that displayed a safety sign should also display the current safety sign
- Safety signs are available from your Distributor or Dealer Parts Department or the factory.

# Important Safety Information

## How to install Safety Signs:

- Be sure that the installation area is clean and dry.
- Decide on the exact position before you remove the backing paper.
- Remove the smallest portion of the split backing paper.
- Align the decal over the specified area and carefully press the small portion with the exposed sticky backing in place.
- Slowly peel back the remaining paper and carefully smooth the remaining portion of the decal in place.
- Small air pockets can be pierced with a pin and smoothed out using the piece of decal backing paper.



## Before Operation

- Carefully study and understand this manual.
- Do not wear loose-fitting clothing, which may catch in moving parts.
- Always wear protective clothing and substantial shoes.
- Assure that all tires are inflated evenly.
- Give the machine a visual inspection for any loose bolts, worn parts or cracked welds, and make necessary repairs. Follow the maintenance safety instructions included with this manual.
- Be sure that there are no tools lying on or in the equipment.
- Do not use the machine until you are sure that the area is clear, especially of children and animals.
- Don't hurry the learning process or take the machine for granted. Ease into it and become familiar with your new equipment.
- Practice operation of your equipment and its attachments. Completely familiarize yourself and other operators with its operation before using.
- Use a tractor equipped with a Roll Over Protection System (ROPS) and fasten your seat belt prior to starting engine.
- The manufacturer does not recommend usage of tractor with ROPS removed.
- Move tractor wheels to the widest recommended settings to increase stability.
- Securely attach to towing unit. Use a high strength, appropriately sized hitch pin with a mechanical retainer and attach safety chain.
- Do not allow anyone to stand between the tongue or hitch and the towing vehicle when backing up to the equipment.

## Important Safety Information



### During Operation

- Children should not be allowed on the product.
- Clear the area of small children and bystanders before moving the implement.
- If using a towing unit, securely attach implement by using a hardened 3/4" pin, a metal retainer, and safety chains if required. Shift towing unit to a lower gear before going down steep downgrades, thus using the engine as a retarding force. Keep towing vehicle in gear at all times. Slow down for corners and rough terrain.
- Make sure you are in compliance with all local and state regulations regarding transporting equipment on public roads and highways. Lights and slow moving signs must be clean and visible by overtaking or oncoming traffic when implement is transported.
- Beware of bystanders, **particularly children!** Always look around to make sure that it is safe to start the engine of the towing vehicle or move the machine. This is particularly important with higher noise levels and quiet cabs, as you may not hear people shouting.
- **NO PASSENGERS ALLOWED!** Do not carry passengers anywhere on, or in, the tractor or equipment, except as required for operation.
- Keep hands and clothing clear of moving parts.
- Do not clean, lubricate or adjust your equipment while it is moving.
- When halting operation, even periodically, set the tractor or towing vehicle brakes, disengage the PTO, shut off the engine and **remove the ignition key.**
- Be especially observant of the operating area and terrain. Watch for holes, rocks or hidden hazards. Always inspect the area prior to operation.
- **DO NOT** operate near the edge of drop-offs or banks.
- **DO NOT** operate on steep slopes as overturns may result.
- Operate up and down (not across) intermediate slopes. Avoid sudden starts and stops.



**Warning: Never backup with the implement on the ground! This will cause damage to the implement. Always lift the implement high enough to clear the ground before backing up.**

## Important Safety Information



### Highway and Transport Operations

- Adopt safe driving practices.
- Keep the brake pedals latched together at all times. **Never use independent braking with machine in tow as loss of control and/or upset of machine can result.**
- Always drive at a safe speed relative to local conditions and ensure that your speed is low enough for an emergency stop to be safe and secure. Keep speed at a minimum.
- Reduce speed prior to turns to avoid the risk of overturning.
- Avoid sudden uphill turns on steep slopes.
- Always keep the tractor or towing vehicle in gear to provide engine braking when going downhill. Do not coast.
- Do not drink and drive!
- Comply with state and local laws governing highway safety and movement of farm machinery on public roads.
- Use approved accessory lighting flags and necessary warning devices to protect operators of other vehicles on the highway during daylight and nighttime transport. Various safety lights and devices are available from your dealer.
- The use of flashing amber lights is acceptable in most localities. However, some localities prohibit their use. Local laws should be checked for all highway and marking requirements.
- When driving the tractor and equipment on the road or highway under 40 kph (20 mph) at night or during the day, use the amber warning lights and a slow moving vehicle (SMV) identification emblem.
- Plan your route to avoid heavy traffic.
- Be a safe and courteous driver. Always yield to oncoming traffic in all situations, including narrow bridges, intersections, etc.
- Be observant of bridge loading ratings. Do not cross bridges rated at lower than the gross weight at which you are operating.
- Watch for obstructions overhead and to the side while transporting.
- Always operate in a position to provide maximum visibility at all times. Make allowances for increased length and weight of the equipment when making turns, stopping the machine, etc.
- Pick the most level route when transporting across fields. Avoid the edges of ditches or gullies and steep hillsides.
- Be extra careful when working in inclines.

## Important Safety Information



### Highway and Transport Operations

- Maneuver the tractor or towing vehicle at safe speeds.
- Avoid overhead wires or other obstacles. Contact with overhead lines could cause serious injury or death.
- Avoid loose fill, rocks and holes, they can be dangerous for equipment operation or movement.
- Allow for machine length when making turns,
- Operate the towing vehicle from the operator's seat only.
- Never stand alongside of machine with engine running or attempt to start engine and/or operate machine while standing alongside of machine.
- Never leave running equipment attachments unattended.
- As a precaution, always recheck the hardware on equipment following every 100 hours of operation. Correct all problems. Follow the maintenance safety procedures.

## Attaching to Tractor



**Warning: When attaching the Greenscape 560, *Never* allow anyone to stand between the Food Plotter and the tractor. Serious injury or death can occur!**

### Attaching the Food Plotter

- Back up the tractor to the Greenscape 560, while lining up the lower tractor links to the Greenscape 560 lower pins.
- Stop the engine, set the brake and remove the key from the tractor and block the tractor tires.
- Secure the tractor lower arms to the Plotter lower pins with lynch pins.
- Attach the tractor top link to the Greenscape 560 with the top link pin and r-clip.
- Adjust the tractor sway bars/chains to center the rotary cutter and remove excess sway.
- Adjust lower links and top link so that the Food Plotter is level.
- Operate the tractor hydraulic controls very slowly up and down. There should be no contact between the Greenscape 560 or any part of the tractor. Failure to check clearance can result in damage to the Greenscape 560 , tractor (especially the tires) and possible injury to the operator. Maintain no less than 6” of clearance between the Greenscape 560 , tractor and tractor tires throughout the complete range of motion.

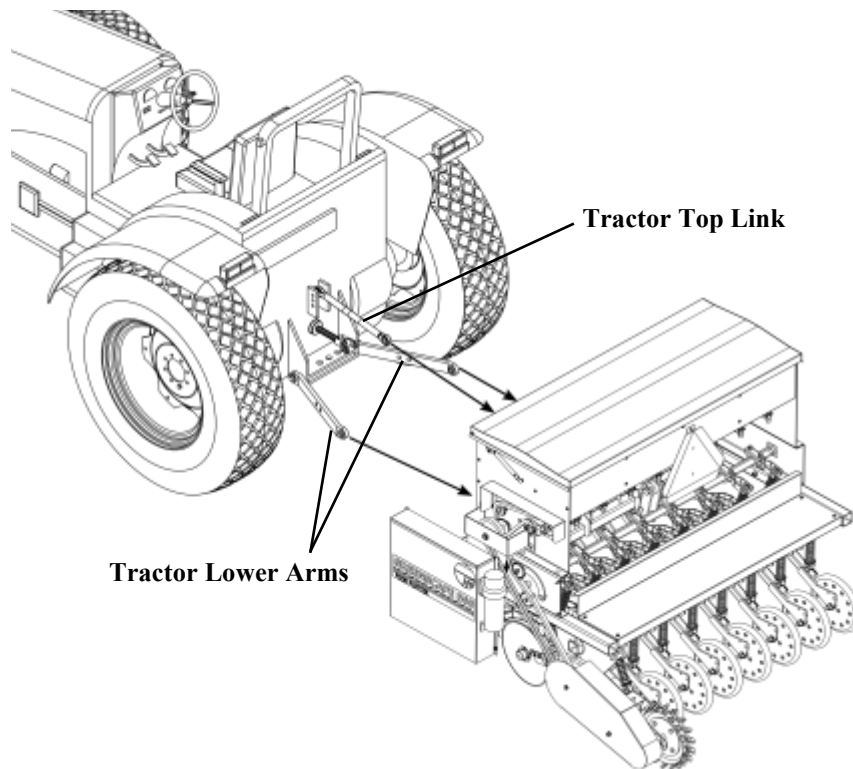

### Operating Instructions

- The top link on the tractor hitch should be properly adjusted to carry the machine level in an operating position. During operation the tractor lift must be fully lowered to allow the machine to follow the contour of the ground.
- The machine is totally ground driven, so proceed with a speed that is most comfortable and safe for existing conditions.
- Be sure to stop forward motion before lifting machine off ground. This practice will stop rollers from ‘free



**Warning: Never backup with the implement on the ground! This will cause damage to the implement. Always lift the implement high enough to clear the ground before backing up.**

## Chain Routing



**Warning:** Never attempt to adjust or change Greenscape 560 roller chains when machine is running. Serious injury or death can occur! Before attempting any work on the tractor or implement, shut off tractor engine, remove key and set brake. Block tires if necessary.

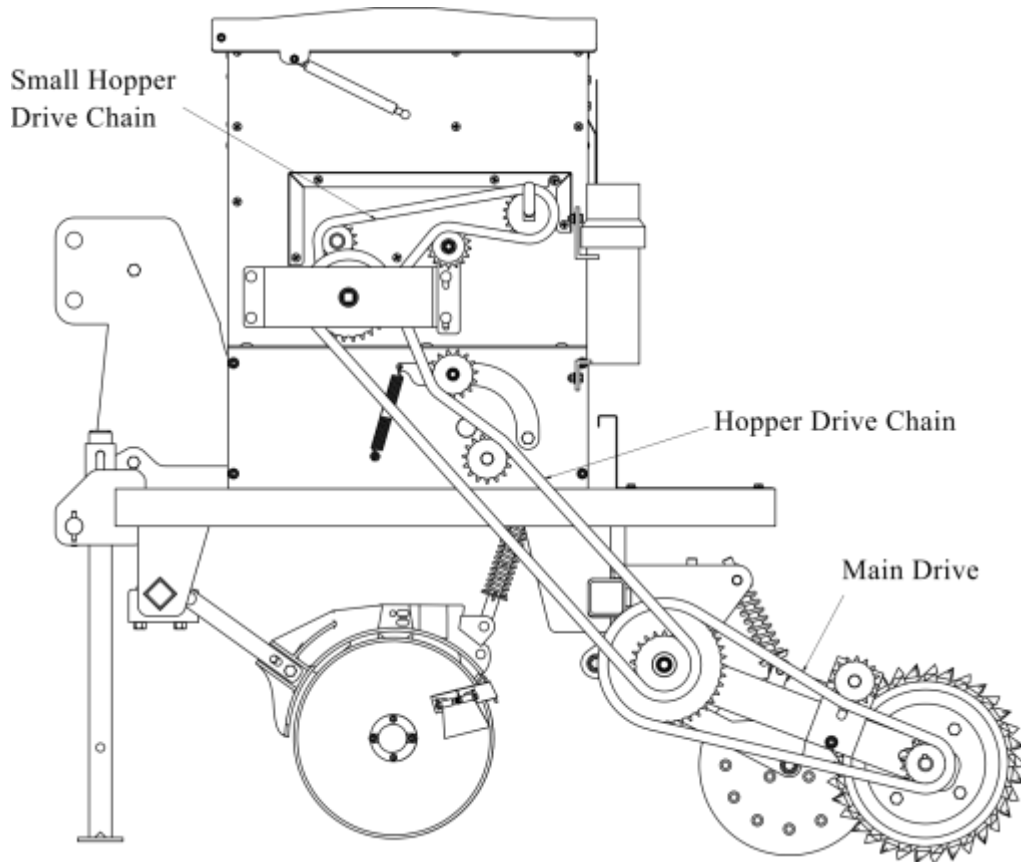

## Seed Rate Adjustment

### Large Hopper

To increase the seed rate, turn the handle on the right side of the hopper **Counterclockwise**. Refer to the indicator reading on the square seed shaft and find the corresponding number on the calibration chart to assure your new rate. Reverse this procedure to decrease rate. Remember to rotate the seed shaft while adjusting to prevent damage to cups especially if seeds are in hopper.

**Note:** When seed cups are fully closed, the indicator should be on 0 (on the rule). This can be adjusted by simply adjusting the opener as needed. Fully open would be 1-3/4”.

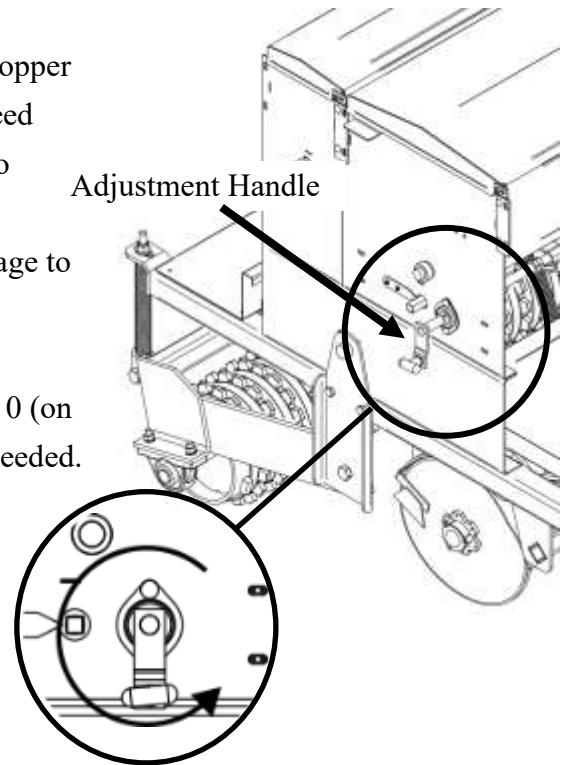

Counter Clockwise

### Small Hopper

The seed rate adjustment for the small hopper is located on the left side of the hopper behind the panel standing at the rear of the machine. To increase the seed rate, turn the handle on the left side of the hopper **Clockwise**. Refer to the indicator reading on the square seed shaft (right side) and find the corresponding number on the calibration chart to assure your new rate. Reverse this procedure to decrease rate. Refer to Charts on pages 16 & 17 of this manual or the rate chart located inside the hopper lid for the corresponding seeding rate.

**Note:** When seed cups are fully closed, the indicator should be on '0' (on the rule). Fully open would be 1-1/8”.

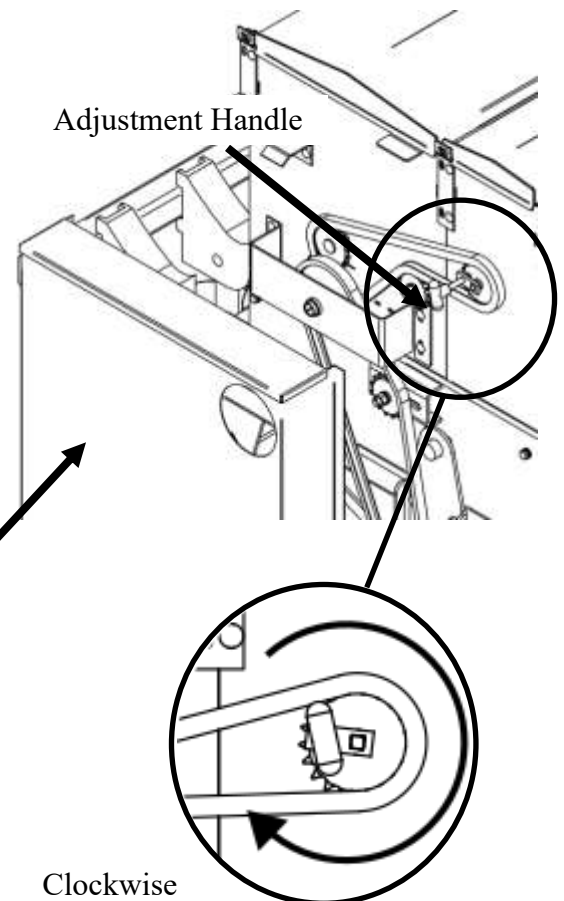

Clockwise



**Warning:** LH Cover removed to show detail only.  
**Never** operate implement unless all shields in place!  
Serious injury or death can occur.

## Setting Application Rates

The most accurate way to set application rates is to drive a predetermined distance and physically catch the seeds dispensed. To do this, remove at least one drop hose and tie a plastic bag onto bottom of seed cup. Travel a determined distance and then weigh the seeds in the bag. Multiply the amount collected by the number of cups on your machine. Refer to the following example to properly calibrate your machine.

To determine area covered calculate the following:

(Disc spacing x number of discs converted to ft.) x distance traveled and then divide by the square feet in an acre.

10 disc with a 7.25" spacing = 72.50" (6.04 ft.) x 500 ft. traveled = 3,020 sq. ft. covered.

43,560 sq. ft. in acre/3,020 = 14.42% of acre covered.

If you collect 16 oz. (1 lb.) of seed from a single seed cup on the #5 setting after driving 500 ft.

(14.42% of an acre), you are putting out 69.35 lbs. per acre.

1 lb. (amount collected) x 10 seed cups = 10 lbs. total output by machine.

Distance traveled = 500 ft. (14.42% of acre)

$1 \times 10 / .1442 = 69.35$  lbs. per acre

NOTE: The tables and rate charts are guidelines only! They are designed to be an aid as a starting point. You must do your own calibration as many factors cause rates to change. Variations in seed/granular size, density, moisture, seed treatment, and the amount of machine overlap will affect the final application rate.

Refer to pages 16 & 17 for "Rate Charts".

## Calibration Charts

### Calibration Chart - Greenscape 560/750 Large Hopper - Chart 2

#### Seed Cup Position

Seed Type	1/4	1/2	3/4	1	1-1/4	1-1/2	1-3/4	Gate Pos.
<b>Kentucky 31 Tall Fescue</b>	<b>27</b>	<b>51</b>	<b>67</b>	<b>87</b>	<b>105</b>	<b>126</b>	<b>147</b>	<b>top</b>
<b>Annual Rye Grass</b>	<b>39</b>	<b>67</b>	<b>88</b>	<b>118</b>	<b>145</b>	<b>168</b>	<b>183</b>	<b>top</b>
<b>Kentucky Blue Grass</b>	<b>22</b>	<b>36</b>	<b>48</b>	<b>66</b>	<b>78</b>	<b>94</b>	<b>109</b>	<b>top</b>
<b>Perennial Rye Grass</b>	<b>36</b>	<b>57</b>	<b>76</b>	<b>103</b>	<b>126</b>	<b>151</b>	<b>160</b>	<b>top</b>
<b>Creeping Red Fescue</b>	<b>19</b>	<b>33</b>	<b>43</b>	<b>61</b>	<b>73</b>	<b>88</b>	<b>99</b>	<b>top</b>
<b>Rebel III Fescue</b>	<b>25</b>	<b>43</b>	<b>57</b>	<b>91</b>	<b>109</b>	<b>130</b>	<b>147</b>	<b>top</b>
<b>Pennington Contractor's Mix</b>	<b>30</b>	<b>46</b>	<b>63</b>	<b>90</b>	<b>109</b>	<b>130</b>	<b>145</b>	<b>top</b>
<b>Orchard Grass</b>	<b>15</b>	<b>25</b>	<b>34</b>	<b>52</b>	<b>64</b>	<b>75</b>	<b>82</b>	<b>top</b>
<b>Wheat</b>	<b>73</b>	<b>126</b>	<b>172</b>	<b>214</b>	<b>252</b>	<b>295</b>	<b>330</b>	<b>top</b>
<b>Oats</b>	<b>30</b>	<b>61</b>	<b>94</b>	<b>130</b>	<b>163</b>	<b>187</b>	<b>213</b>	<b>top</b>
<b>Fertilizer 10-10-10</b>	<b>88</b>	<b>151</b>	<b>199</b>	<b>297</b>	<b>367</b>	<b>430</b>	<b>472</b>	<b>middle</b>
<b>Top Dress 16-0-0</b>	<b>105</b>	<b>183</b>	<b>246</b>	<b>367</b>	<b>451</b>	<b>535</b>	<b>687</b>	<b>top</b>

### Calibration Chart - Greenscape 560/750 Small Hopper - Chart 3

#### "lbs. per acre"

Seed Type	3/16	1/4	3/8	1/2	3/4	1	1-1/8
<b>Pennsicola Bahai</b>	<b>4</b>	<b>9</b>	<b>12</b>	<b>16</b>	<b>21</b>	<b>30</b>	<b>33</b>
<b>Centipede</b>	<b>6</b>	<b>9</b>	<b>15</b>	<b>22</b>	<b>34</b>	<b>43</b>	<b>51</b>
<b>Hulled Bermuda</b>	<b>6</b>	<b>10</b>	<b>16</b>	<b>24</b>	<b>36</b>	<b>48</b>	<b>55</b>
<b>Red Clover</b>	<b>7</b>	<b>12</b>	<b>19</b>	<b>25</b>	<b>43</b>	<b>55</b>	<b>67</b>
<b>Landino Clover</b>	<b>6</b>	<b>10</b>	<b>19</b>	<b>25</b>	<b>40</b>	<b>54</b>	<b>63</b>
<b>Dixie Crimson</b>	<b>7</b>	<b>12</b>	<b>19</b>	<b>25</b>	<b>43</b>	<b>55</b>	<b>67</b>
<b>White Millet</b>	<b>4</b>	<b>12</b>	<b>19</b>	<b>25</b>	<b>42</b>	<b>54</b>	<b>64</b>
<b>Total Alfalfa</b>	<b>7</b>	<b>12</b>	<b>19</b>	<b>24</b>	<b>40</b>	<b>52</b>	<b>61</b>
<b>Carpet Grass</b>	<b>4</b>	<b>9</b>	<b>13</b>	<b>24</b>	<b>30</b>	<b>37</b>	<b>45</b>
<b>Tiffany Teff</b>	<b>8</b>	<b>11</b>	<b>21</b>	<b>27</b>	<b>44</b>	<b>54</b>	<b>60</b>
<b>Buffalo Grass</b>	<b>-</b>	<b>5</b>	<b>6</b>	<b>9</b>	<b>12</b>	<b>17</b>	<b>20</b>

## Calibration Charts

### Calibration Chart - Greenscape 560/750 Small Hopper - Chart 4

**"lbs. per acre"**

Seed Type	Flute Engagement						
	3/16	1/4	3/8	1/2	3/4	1	1-1/8
<b>Sorghum</b>	<b>9</b>	<b>16</b>	<b>22</b>	<b>33</b>	<b>46</b>	<b>57</b>	<b>76</b>
Kobe Lespedza	4	6	9	16	22	25	30
<b>Korean Lespedza</b>	<b>6</b>	<b>9</b>	<b>15</b>	<b>24</b>	<b>36</b>	<b>43</b>	<b>52</b>
Bi-Color Lespedza	10	18	24	33	48	64	75
<b>Brown Top Millet</b>	<b>7</b>	<b>10</b>	<b>19</b>	<b>22</b>	<b>33</b>	<b>40</b>	<b>46</b>
Japanese Millet	6	9	15	22	30	36	39
<b>Hybrid Pearl Millet</b>	<b>12</b>	<b>19</b>	<b>25</b>	<b>33</b>	<b>52</b>	<b>72</b>	<b>88</b>
Rape	9	13	18	25	43	60	82
<b>Switchgrass</b>	<b>9</b>	<b>13</b>	<b>18</b>	<b>22</b>	<b>31</b>	<b>39</b>	<b>42</b>

### Calibration Chart - Greenscape 560/750 Large Hopper - Chart 6

**Seed Cup Position (lbs per acre)**

Seed Type	1/4	1/2	3/4	1	1-1/4	1-1/2	1-3/4	Gate Pos.
<b>Barley</b>	-	<b>80</b>	<b>116</b>	<b>155</b>	<b>193</b>	<b>217</b>	<b>253</b>	<b>top</b>
Wheatgrass	-	80	114	154	190	214	250	top
<b>Soybeans</b>	-	<b>100</b>	<b>165</b>	<b>205</b>	<b>246</b>	<b>288</b>	<b>327</b>	<b>top</b>
Sunflower	-	33	45	58	70	85	100	top
<b>Corn</b>	-	<b>112</b>	<b>198</b>	<b>238</b>	<b>298</b>	<b>360</b>	<b>418</b>	<b>middle</b>

## Seeds per Seed Box

### Legume Seedbox (small hopper):

All small round types seeds that flow easily and are generally planted at a fairly low rate, typically from as low as 3 lbs. per acre to about 65 lbs. per acre. This would include all clover, alfalfa, brassicas and many flowers that have seed counts from about 100,000 seeds/lb to well over 7,000,000 seeds/lb. The seed size diameter would be from about 3/16" (5 mm) to as small as 1/128" (0.019 mm).

### Large Seedbox:

All cereal grains, rye, wheat, oats barley and rice. Any seeds that are irregular shaped (elongated, rice shape) but still flow easily should be planted with this box. Most cool season grasses, such as fescue, ryegrass and bluegrass would be planted with this box. All types of beans, peas, corn and sunflowers can be planted with this box. Seed sizes would be from about 3/8" (9.5 mm) elongated up to about 3/8" (9.5 mm) diameter round. Seeding rates are typically from about 25 lbs. per acre to 400 lbs. per acre.

## Lubrication and Maintenance

**Important:** It is important to thoroughly clean the seeder after use. Failure to do so can cause irreparable damage to the seed cups and drive system. Grease and turn the Seed adjustment handle to ensure grease lubricates the threads.

- 1 Hour** Check all fasteners and hardware including set screws in sprockets and bearing collars and re-tighten as necessary.
- 8 Hours** Grease bearings and inspect chains for tightness.
- 25 Hours** Remove guard cover on right hand side of machine and inspect chain; lubricate using multi-purpose lithium base grease.
- As needed:** Remove any crop residue, grasses, weeds, or debris wrapped around shaft near bearings. This can cause bearings to overheat and lead to premature failure.
- Always:** Protect the machine from weather. NEVER leave fertilizer in hopper. Do not leave seed in hopper for more than 24 hours. Remove all fertilizer and seeds from hopper. Thoroughly clean hoppers and lubricate all drive chains before storage.

### Changing Discs







**Important:** When replacing the discs, it is extremely important to remember that one of the disc hubs has left hand threads and the other right hand threads. The threads can be stripped if removed improperly. Left side hub, turn Clockwise to loosen and turn counter-clockwise to tighten. Right side hub, turn counter-clockwise to loosen and clockwise to tighten.

- Step 1: Remove the dust cap.
- Step 2: Remove the external scraper dust cap.
- Step 3: Remove hub nuts.
- Step 4: Unscrew the hub from the disc support.
- Step 5: Replace the discs and reassemble.



**Important:** When replacing the discs, it is extremely important to remember that the left disc hub has reverse (LH) threads. The right disc hub has normal (RH) threads. If turned incorrectly, they can strip.

# Torque Specifications

Torque Specifications for Common Bolt Sizes															
Inches		Bolt Head Identification						Metric		Bolt Head Identification					
															
		Grade 2		Grade 5		Grade 8		Class 5.8		Class 8.8		Class 10.9			
Bolt size (inches)	Thread pitch	N.m	ft-lb	N.m	ft-lb	N.m	ft-lb	Bolt size (metric)	Thread pitch	N.m	ft-lb	N.m	ft-lb	N.m	ft-lb
1/4"	20	7	5	11	8	16	12	M5	0.08	4	3	6	4	9	7
1/4"	28	8	6	13	10	19	14	M6	1	6	4	10	7	15	11
5/16"	18	15	11	24	17	33	25	M6	1.25	16	12	25	18	36	27
5/16"	24	17	13	26	19	37	27	M8	1	17	13	26	19	38	28
3/8"	16	27	20	42	31	59	44	M10	1.5	31	23	48	35	71	52
3/8"	24	31	23	47	35	67	49	M10	1.25	33	24	51	38	75	55
7/16"	14	43	32	67	49	95	70	M10	1	35	26	53	39	78	58
7/16"	20	48	36	75	55	106	78	M12	1.75	54	40	84	62	123	91
1/2"	13	66	48	102	75	144	106	M12	1.5	56	41	87	64	128	94
1/2"	20	75	55	115	85	163	120	M12	1.25	59	44	90	66	133	98
9/16"	12	95	70	147	109	206	154	M14	2	84	62	133	98	195	144
9/16"	18	106	79	164	121	232	171	M14	1.5	94	69	142	105	209	154
5/8"	11	132	97	203	150	287	212	M16	2	131	97	206	152	302	223
5/8"	18	149	110	230	170	325	240	M16	1.5	141	104	218	161	320	236
3/4"	10	233	172	361	266	509	376	M18	2.5	181	133	295	218	421	310
3/4"	16	261	192	403	297	566	420	M18	2	196	145	311	229	443	327
7/8"	9	226	167	382	282	548	406	M18	1.5	203	150	327	241	465	343
7/8"	14	249	184	424	313	606	450	M20	2.5	256	189	415	306	592	437
1"	8	339	250	514	377	744	554	M20	1.5	288	212	454	335	646	476
1"	12	371	273	555	406	786	583	M22	2.5	344	254	567	418	807	595
1-1/8"	7	480	354	717	526	1038	765	M22	1.5	381	281	613	452	873	644
1-1/8"	12	539	397	792	581	1138	840	M24	3	444	327	714	526	1017	750
1-1/4"	7	677	500	959	704	1383	1017	M24	2	488	360	769	567	1095	806
1-1/4"	12	750	553	1062	777	1530	1120	M27	3	656	484	1050	774	1496	1103
1-3/8"	6	888	655	1292	949	1827	1350	M27	2	719	530	1119	825	1594	1176
1-3/8"	12	1011	746	1468	1083	2127	1560	M30	3.5	906	668	1420	1047	2033	1496
1-1/2"	6	1179	869	1703	1254	2457	1810	M30	2	1000	738	1600	1180	2250	1659
1-1/2"	12	1326	978	1944	1424	2772	2040	M36	4	1534	1131	2482	1830	3535	2607

## Notes:

This chart is an approximate estimate of torque values.

Always tighten hardware to these values unless a different torque value or tightening procedure is listed for a specific application.

Fasteners must always be replaced with the same grade as specified in the manual.

Always use the proper tool for tightening hardware: SAE for SAE hardware and Metric for Metric hardware.

Make sure that fastener threads are clean and that you properly start thread engagement.

**Page left blank intentionally**

# GREENSCAPE 560

## Minimum Till Drill

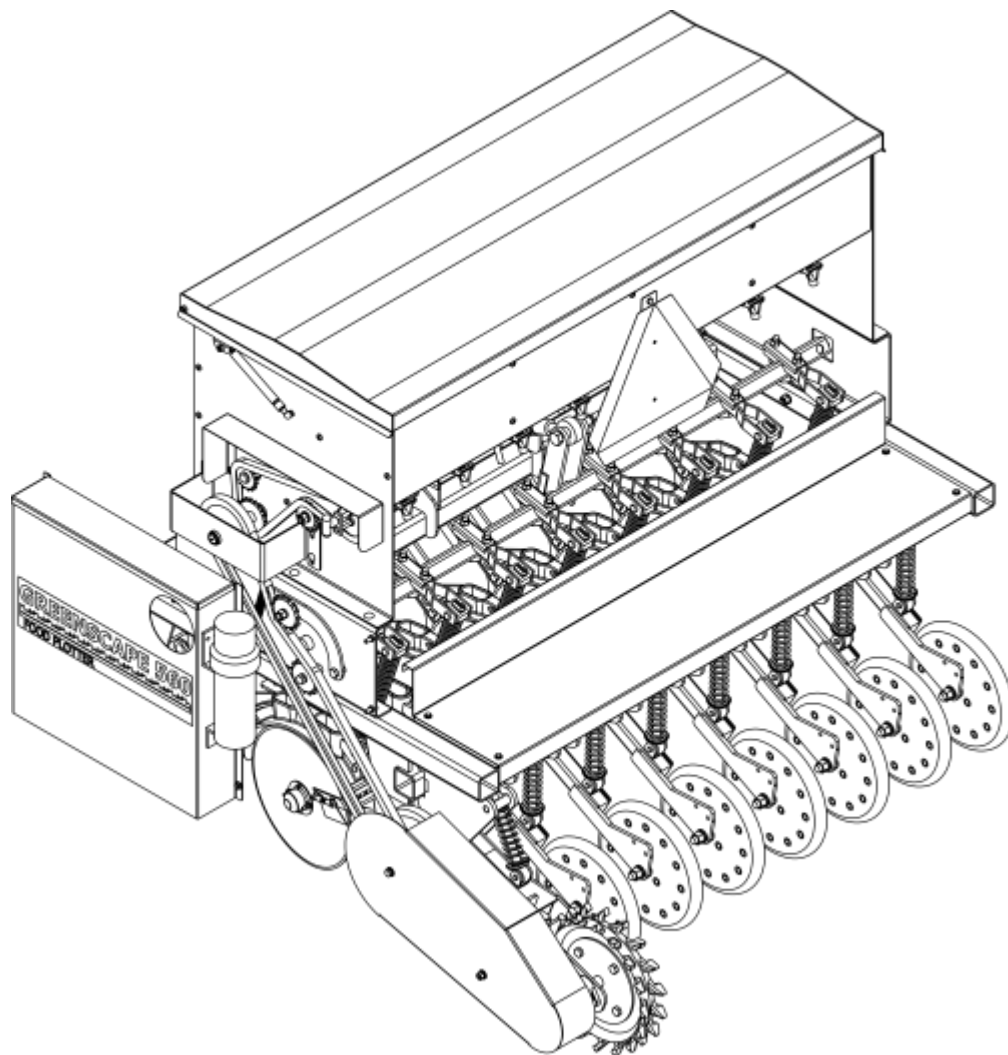

## Parts Manual

# Hopper

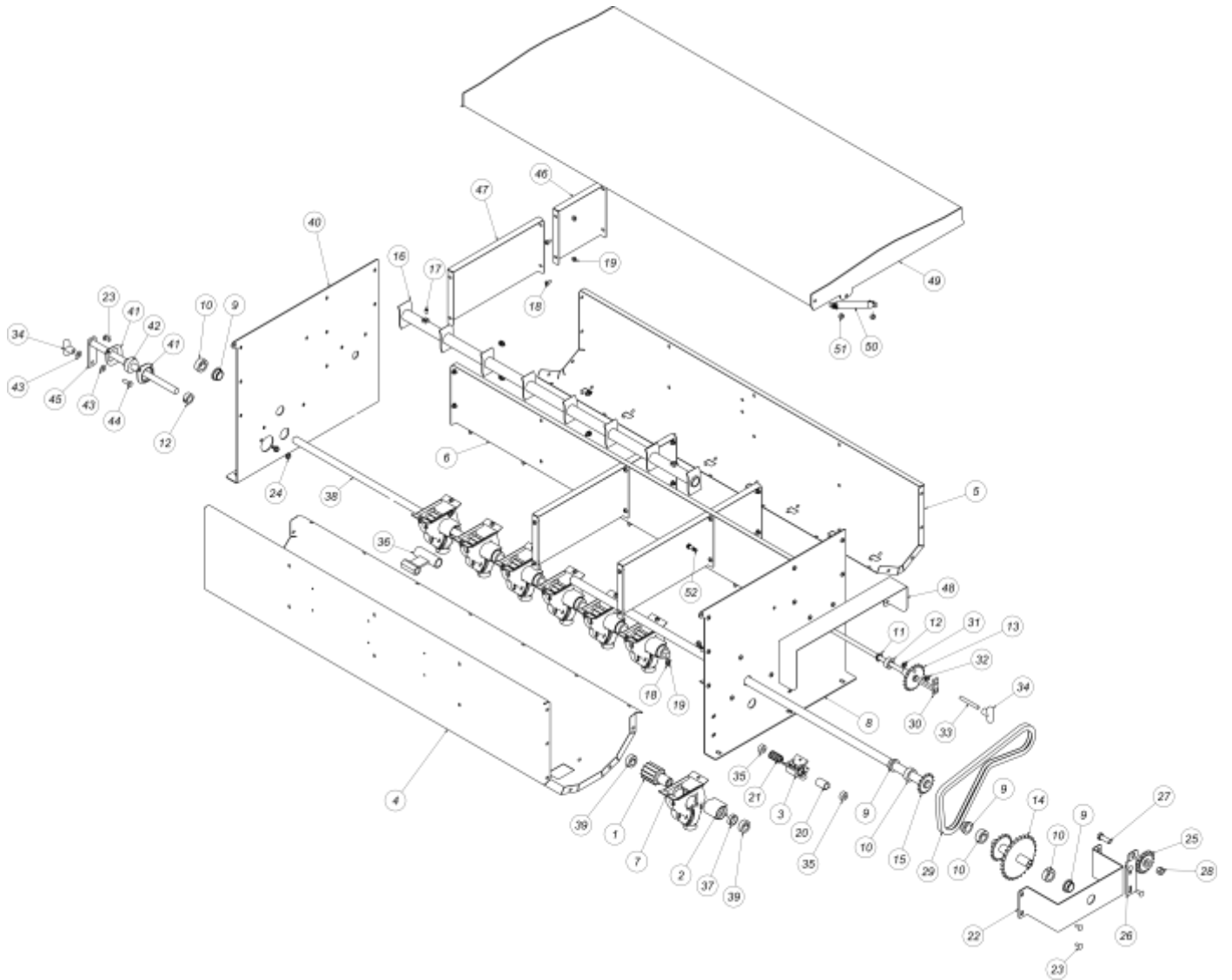

# Hopper

Item	Part #	Description	Qty.
1	SB100641	Seed cup gear	8
2	SB100642	Seed cup spacer	8
3	SB100710	Small seed cup housing	8
4	SB142633	Large hopper formed section	1
5	SB142634	Small hopper formed section	1
6	SB142635	Hopper divider front	1
7	SB100643	Seed cup, housing large	8
8	SB142636	Hopper end panel LH bolt together	1
9	SB100691	Igus bearing	4
10	SB100690	Shaft collar 1" bore	4
11	SB101341	Igus clip bearing	1
12	SB100744	Shaft collar 3/4" bore	3
13	SB100718	Small hopper drive sprocket weldment	1
14	SB142642	Transmission sprocket weldment 5028 TO 4020	1
15	SB142638	Agitator shaft weldment	1
16	SB142640	Agitator shaft weldment large hopper bolt together	1
17	SB500164	Set screw 3/8-16X1/2	2
18	SB500124	Machine screw truss head Phillips 1/4-20X5/8 GR. 5	83
19	SB500125	Nut, flange 1/4-20 GR. 2	83
20	SB100708	Small seed cup spacer	8
21	SB100709	Small seed cup gear	8
22	SB142647	Outer bearing bracket	1
23	SB500116	Bolt, carriage 5/16-18X3/4" GR.5	6
24	SB500121	Nut, flange 5/16-18 GR. 2	6
25	SB100625	Idler sprocket 40BB17Hx1/2"	1
26	SB142648	Idler bracket #40	1
27	SB500106	Bolt, HH 1/2-13x-1/2 GR. 5	1
28	SB500109	Nut, nylok 1/2-13 GR. 2	1
29	SB142649	Small hopper drive chain #40 (41 INSIDE LINKS) APPROX 40.5" LONG)	1
30	SB142653	Driveshaft weldment small hopper bolted	1
31	SB500560	Nut, nylok thin 3/8-16 GR.2	1
32	SB500586	Nut, distorted thread center lock 3/8-16 GR. 2	1
33	SB101284	Threaded rod	1
34	SB101287	Adjustment know	2
35	SB100548	Shaft collar 1/2" bore	16
36	SB142655	Large hopper shaft adjuster bolted	1
37	SB142657	Large seed cup PVC spacer	9
38	SB142658	Drive shaft large hopper bolted	1

# Hopper

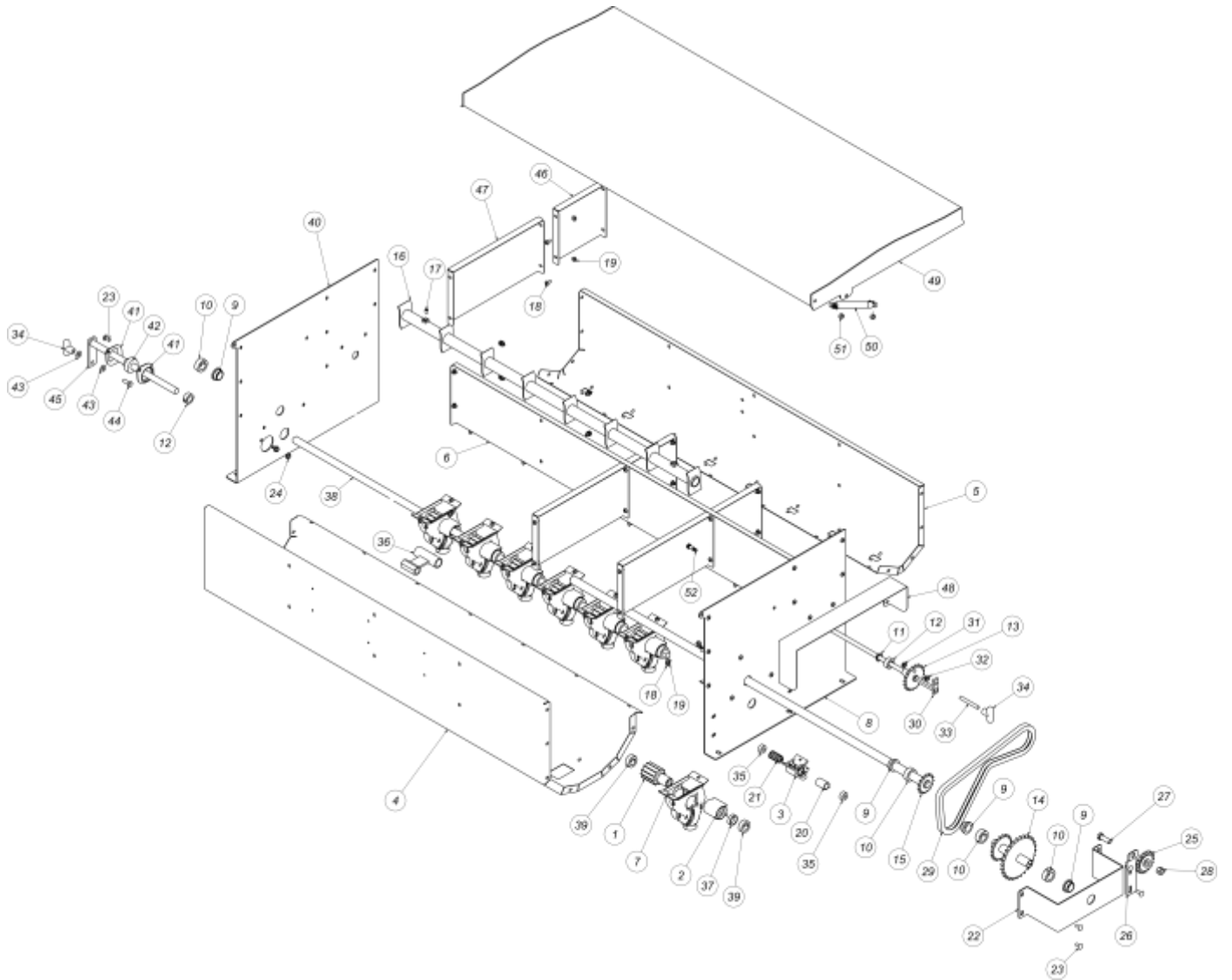

## Hopper

Item	Part #	Description	Qty.
39	SB106278	Shaft collar 7/8" bore	14
40	SB142637	Hopper end panel RH bolt together	1
41	SB100647	2 hole bearing flange	2
42	SB100646	Bearing insert	1
43	SB100732	3/8" Plastic washer	2
44	SB500131	Bolt, HH 3/8-16X1 GR. 5	1
45	SB142681	Adjustment handle weldment large hopper bolted	1
46	SB142684	Small hopper baffle bolt in	3
47	SB142685	Large hopper baffle bolt in	3
48	SB142718	Bolt on inner panel guard	1
49	SB142707	Lid weldment	1
50	SB142714	Gas spring	2
51	SB500163	Nut, nylok 5/16-18 GR. 2	6
52	SB500671	Shoulder bolt	2

# Frame

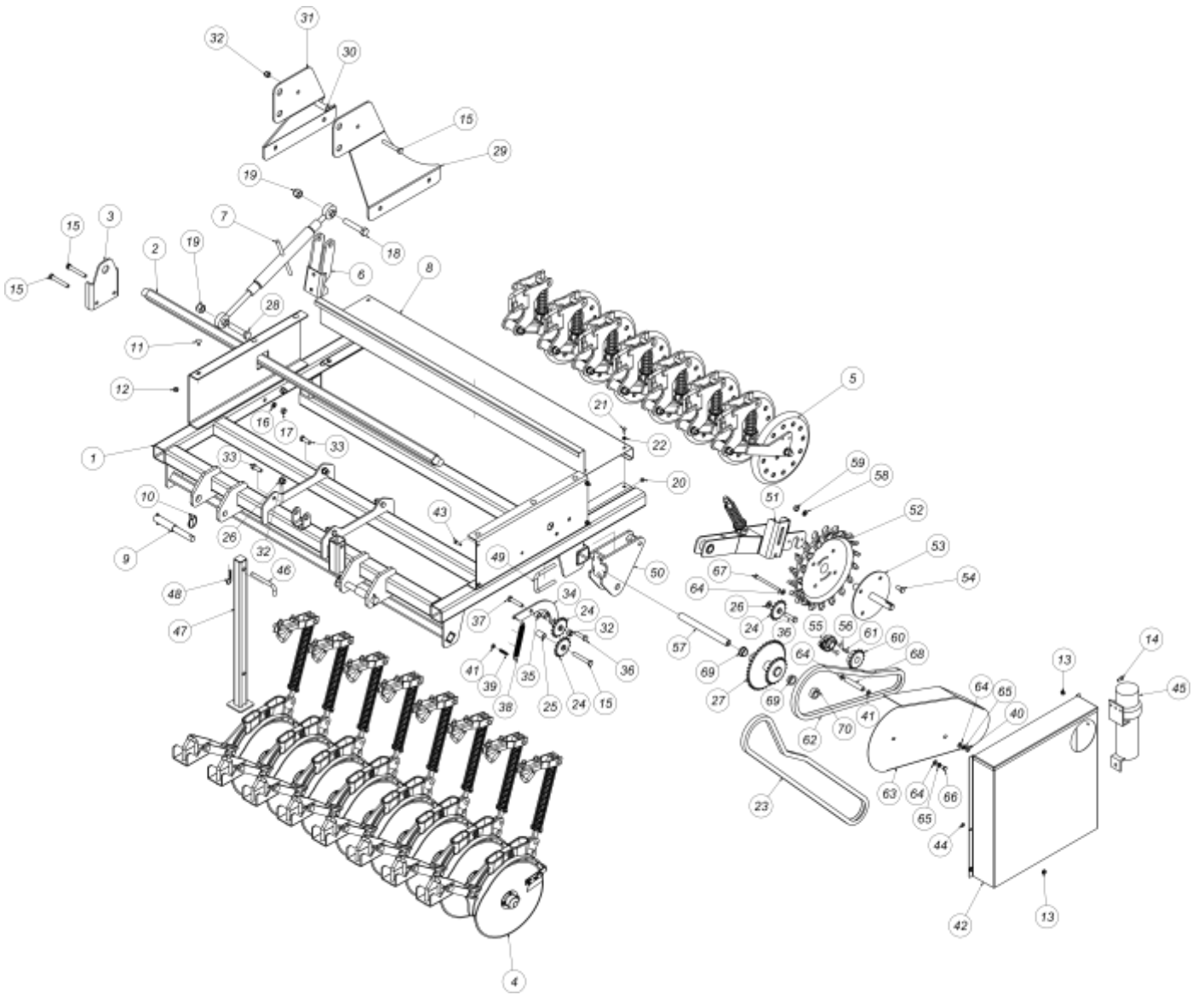

## Frame

Item	Part #	Description	Qty.
1	SB142736	Disc opener seeder main frame weldment 5ft	1
2	SB142742	Disc opener pivot tubing weldment	1
3	SB142744	Disc opener pivot tube mount plate	1
4	-	Double disc opener Assembly (Refer to page 32-33)	8
5	-	Press Wheel Assembly (Refer to pages 34-35)	7
6	SB135366	Top link mount weldment	1
7	SB100757	Top link	1
8	SB142748	Formed walk board	1
9	SB100755	Hitch pin assembly	2
10	SB100756	Lynch pin 7/16	2
11	SB500139	Bolt, carriage 3/8-16x3/4 GR.5	6
12	SB500132	Nut, flange 3/8-16 GR.2	6
13	SB500121	Nut, flange 5/16-18 GR. 2	8
14	SB500169	Bolt, HH 5/16-18x3/4 GR. 5	4
15	SB500103	Bolt, HH 1/2-13x3-1/2 GR. 5	4
16	SB500073	Washer, lock 1/2"	2
17	SB500104	Nut, Hex 1/2-13 GR. 2	2
18	SB500253	Bolt, HH 3/4-10x4 GR. 5	1
19	SB500113	Nut, nylok 3/4-10 GR. 2	2
20	SB500125	Nut, flange 1/4-20 GR. 2	4
21	SB500118	Bolt, HH 1/4-20x3/4 GR. 5	4
22	SB500051	Washer, flat 1/4"	4
23	SB142765	Hopper drive chain #50	1
24	SB100745	Idler sprocket 50BB15HX1/2"	3
25	SB142766	Idler sprocket standoff spacer	1
26	SB500055	Washer, flat 1/2"	7
27	SB143426	Transmission sprocket weldment lower	1
28	SB500126	Bolt, HH 3/4-10x3 1/2 GR. 5	1
29	SB142775	Center hitch plate LH	1
30	SB142777	Center hitch spacer	1
31	SB142776	Center hitch plate RH	1
32	SB500109	Nut, nylok 1/2-13 GR. 2	9
33	SB500106	Bolt, HH 1/2-13x1-1/2 GR. 5	4
34	SB142778	Idler sprocket tensioner bracket	1
35	SB142779	Idler tensioner bracket spacer	2
36	SB500141	Bolt, HH 1/2-13x2 GR. 5	2
37	SB500237	Bolt, HH 1/2-13x2 1/2 GR. 5	1
38	SB142780	Spring, extension with hook ends	1

# Frame

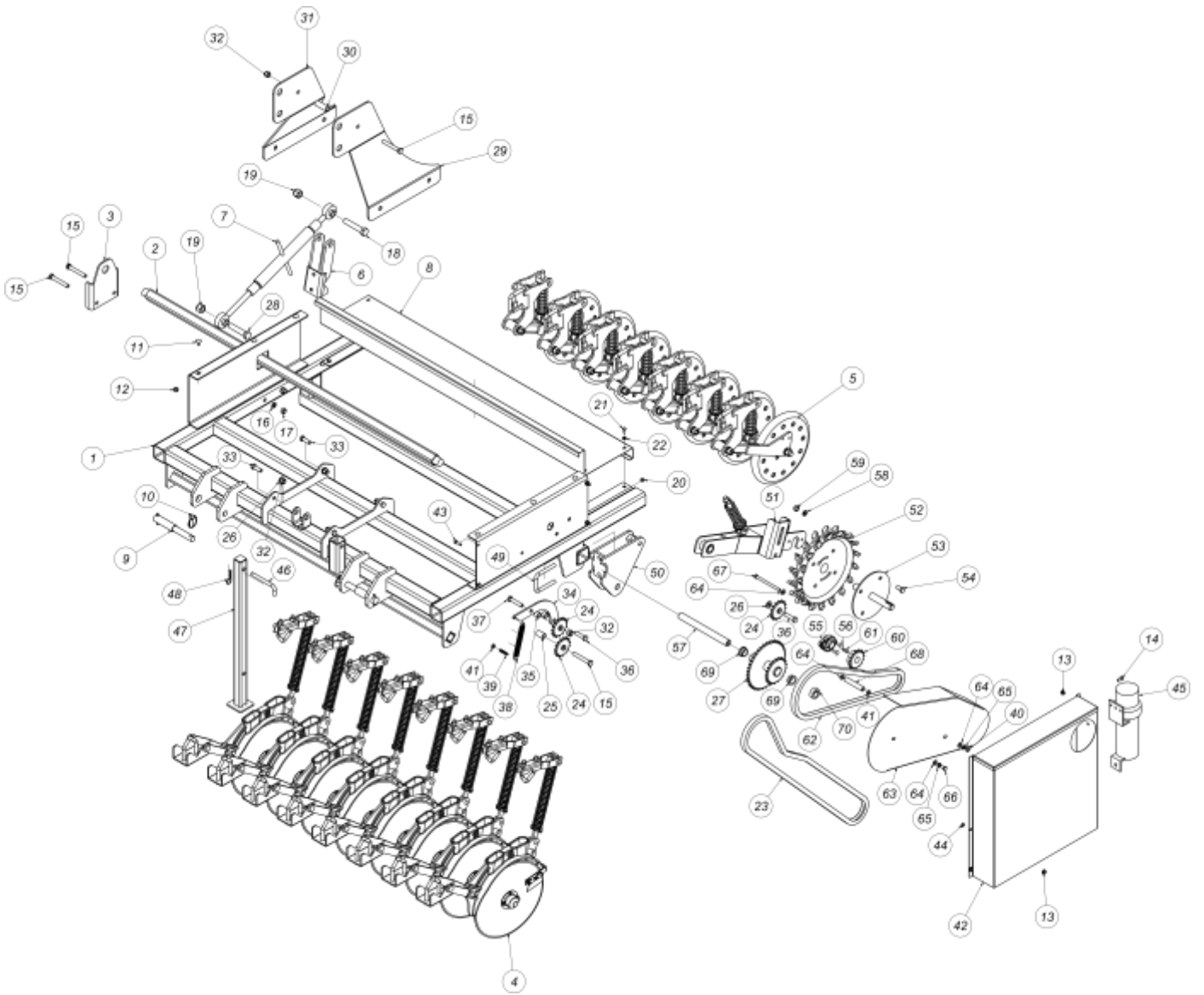

## Frame

Item	Part #	Description	Qty.
39	SB142782	Extension spring stud anchor 3/8	1
40	SB500115	Nut, hex 3/8-16 GR.2	2
41	SB500186	Nut, jam 3/8-16 GR. 2	2
42	SB142783	Top guard weldment	1
43	SB500207	Bolt, HH 5/16-18x1 GR. 5	4
44	SB500185	Nut, jam 5/16-18 GR.2	4
45	SB129210	Manual canister large	1
46	SB105122	Bent pin 1/2" x 4	1
47	SB143149	Jackstand weldment	1
48	SB105123	Hair clip pin	1
49	SB143430	Drive wheel assembly new style	1
50	SB143431	Rear drive wheel mounting plate weldment	1
51	SB143435	Wheel yoke weldment	1
52	SB143445	Cast closing wheel	1
53	SB143441	Drive wheel shaft weldment	1
54	SB500156	Bolt, HH 1/2-13x1 GR.5	1
55	SB100461	Bearing, 2 bolt flange 1" bore	1
56	SB500292	Bolt, carriage 5/16-18x1	1
57	SB143434	Pivot pin	1
58	SB500073	Washer, lock 1/2	1
59	SB500104	Nut, hex 1/2-13	1
60	SB109353	Sprocket 50BS15H (1" bore)	1
61	SB100693	Machine key square, 1/4" x 1/4" x 1"	1
62	SB142764	Wheel drive chain #50	1
63	SB143446	Drive wheel chain guard weldment	1
64	SB500053	Washer, flat 3/8"	4
65	SB500071	Washer, lock 3/8"	2
66	SB500217	Bolt, HH 3/8-16x3/4 GR. 5	1
67	SB500223	Bolt, HH 3/8-16x5 GR. 5	1
68	SB143449	Drive wheel chain guard spacer	1
69	SB100691	IGUS bearing MFI1620-10	2
70	SB100690	Shaft collar 1" bore	1

# Roller Chain

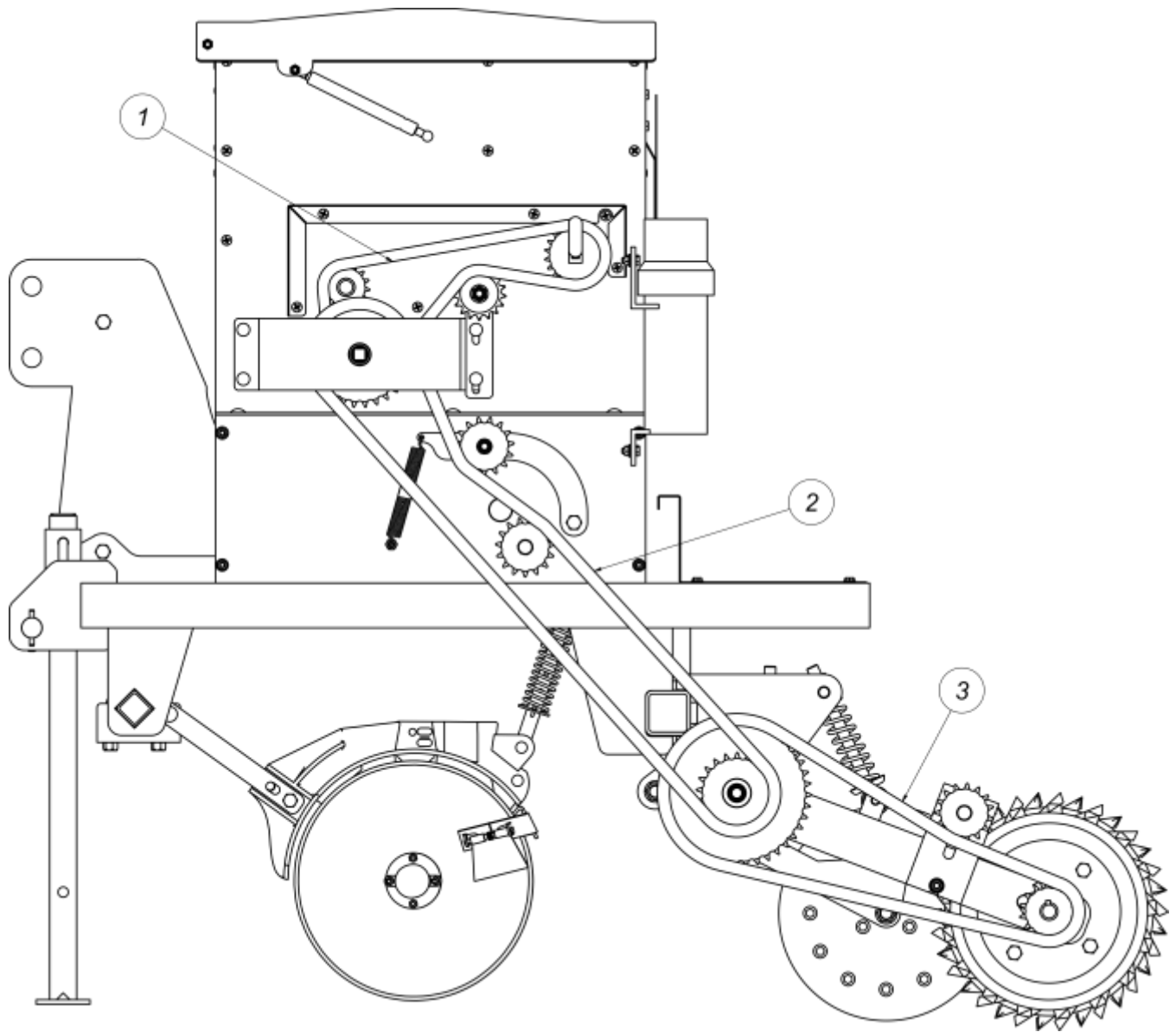

## Roller Chain

<b>Item</b>	<b>Part #</b>	<b>Description</b>	<b>Qty.</b>
1	SB142649	Small hopper drive chain #40	1
2	SB142765	Hopper drive chain #50	1
3	SB142764	Wheel drive chain #50	1



## Double Disc Opener Assembly

Item	Part #	Description	Qty.
1	SA7001F	Disc assembly complete, front	7
2	SA6002	Disc support bracket short, front	7
3	SA7003	V-bolt M12x1.75	14
4	SA6004	Disc, single	14
5	SA7006	Seed drill casting, front	7
6	SA3001	Seed tube retainer	7
7	DL6007	External scraper	7
8	DL6006	Internal scraper	7
9	SA6005	Disc support bearing	14
10	OS203207	Oil seal - M20 x 32 x 7	14
11	B60042RS	Bearing 6004 2RS	14
12	SRI-45	Snap ring - internal - M45	14
13	SA6009	Bearing grease cap	14
14	FW16	Washer flat M16	14/
15	BM061025	Bolt HH M06-1.0x25	84
16	NM0610	Nut HH M06-1.0	84
17	SA4027	Stud LH, disc assembly <i>*WARNING! See page 18 before removing/replacing Studs</i>	7
	SA4028	Stud RH, disc assembly <i>*WARNING! See page 18 before removing/replacing Studs</i>	7
18	TNM1620L	Thin hex nut M16-2.0 LH thread (for SA4027 LH stud only)	7
	TNM1620R	Thin hex nut M16-2.0 RH thread (for SA4028 RH stud only)	7
19	BM061012	Bolt HH M06-1.0x12	42
20	NM1420	Nut HH M14-2.0	28
21	NM12175	Nut HH M12-1.75	14
22	BM1217550	Bolt HH M12-1.75x50	14
23	FW08	Washer flat M08	14
24	BM0812510	Bolt HH M08-1.25x10	14
25	SA6003	Disc support	7
26	LW12	Washer lock M12	14
27	FW12	Washer flat M12	14
28	SA7004L	Top coulter support bracket, left	7
29	SA7004R	Top coulter support bracket, right	7
30	FNM08125	Flanged nut M08-1.25	28
31	BM0812520	Bolt HH M08-1.25x20	21
32	SA6011	Scraper mount bracket	7
33	SA4023	Damper rod	7
34	SA4024	Damper guide	7
35	SA4025	Star washer	7
36	SA4026	Retainer clip	7
37	SA7002	Disc spring	7
38	CP2.5x20	Cotter pinM2.5x20	7
39	SA6010	Pin, clevis M6x40	7

# Press Wheel Assembly

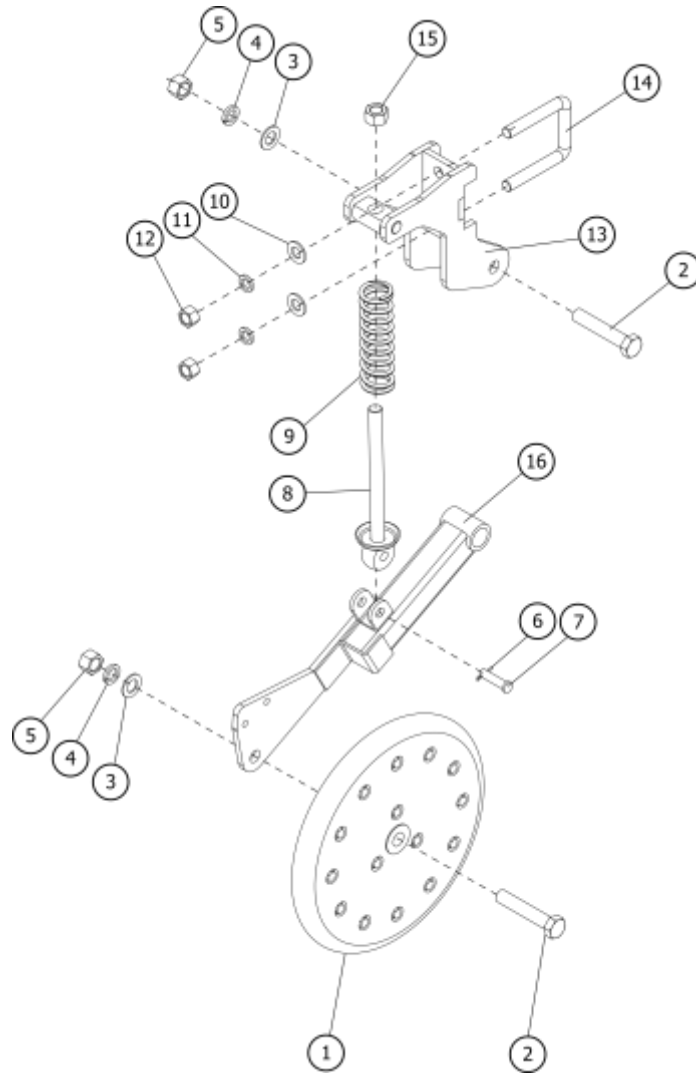

## Press Wheel Assembly

<b>Item</b>	<b>Part #</b>	<b>Description</b>	<b>Qty.</b>
1	SA4159	Press wheel	7
2	BM162085	Bolt HH M16-2.0x85	14
3	FW16	Washer flat M16	14
4	LW16	Washer lock M16	14
5	NM1620	Nut M16-2.0	14
6	SA4160	Clevis pin M10 x 40	7
7	CP2.5x20	Cotter pin M2.5x 20	7
8	SA4161	Press wheel rod	7
9	SA4162	Press wheel spring	7
10	FW14	Washer flat M14	14
11	LW14	Washer lock M14	14
12	NM1420	Nut HH M14-2.0	14
13	SA4163	Press wheel bracket	7
14	SA8006	U-Bolt	7
15	SNM1620	Nut stover M16-2.0	7
16	SA4164	Press wheel arm	7

# Decals

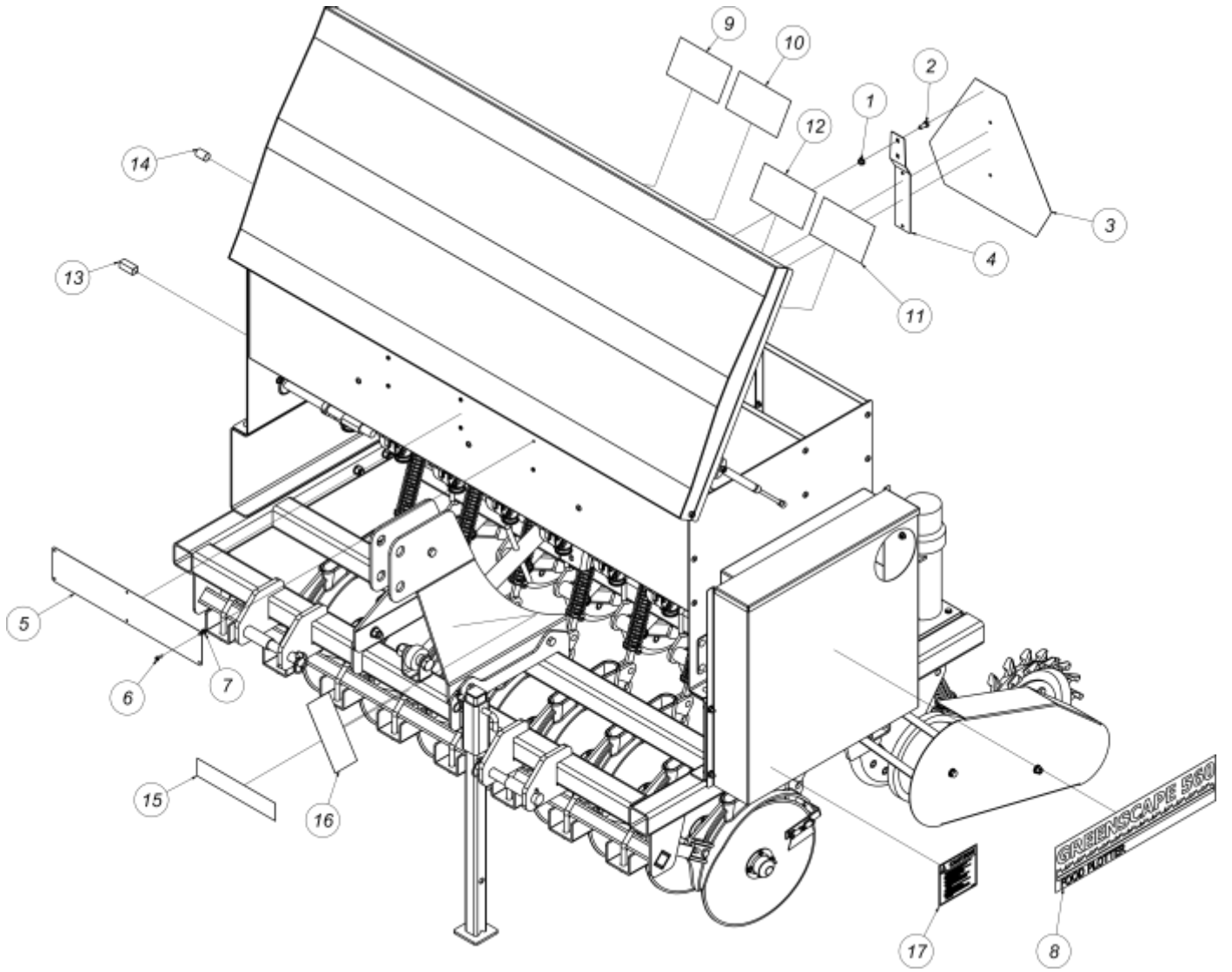

## Decals

Item	Part #	Description	Qty.
1	SB500121	Nut, flange 5/16-18 GR. 2	8
2	SB500169	Bolt, HH 5/16-18X3/4 GR. 5	4
3	SB101180	SMV emblem	1
4	SB101181	SMV offset bracket	1
5	SB143469	Greenscape placard	1
6	SB500122	Machine screw truss head Phillips 10-24x5/8 GR. 5	6
7	SB500123	Nut, flange #10-24 GR. 2	6
8	SB143129	Decal Greenscape 560 large	1
9	SB135714	Decal, Greenscape 560/750 Calibration Chart 2 large hopper	1
10	SB137055	Decal, Greenscape 560/750 Calibration Chart 6 large hopper	1
11	SB135715	Decal, Greenscape 560/750 Calibration Chart 3 small hopper	1
12	SB135716	Decal, Greenscape 560/750 Calibration Chart 4 small hopper	1
13	SB101177	Decal, scale large hopper	1
14	SB101178	Decal, scale small hopper	1
15	SB101400	Decal, warning falling off	1
16	SB101401	Decal, Warning Crushing"	1
17	SB100759	Caution decal	1

# Warranty

## LIMITED WARRANTY

Belco Resources Equipment warrants to the original purchaser of any new piece of machinery from Belco Resources Equipment, purchased from an authorized Belco Resources Equipment dealer, that the equipment be free from defects in material and workmanship for a period of one (1) year for non-commercial, state, and municipalities' use, ninety (90) days for commercial use from date of retail sale. Warranty for rental purposes is thirty (30) days. The obligation of Belco Resources Equipment to the purchaser under this warranty is limited to the repair or replacement of defective parts.

Replacement or repair parts installed in the equipment covered by this limited warranty are warranted for ninety (90) days from the date of purchase of such part or to the expiration of the applicable new equipment warranty period, whichever occurs later. Warranted parts shall be provided at no cost to the user at an authorized Belco Resources Equipment dealer during regular working hours. Belco Resources Equipment reserves the right to inspect any equipment or parts, which are claimed to have been defective in material or workmanship.

This limited warranty does not apply to and excludes wear items such as shear pins, tires, tubes knives, blades or other wear items. Oil or grease is not covered by this warranty.

All obligations of Belco Resources Equipment under this limited warranty shall be terminated if:

- Proper service is not performed on the machine.

- The machine is modified or altered in any way.

- The machine is being used or has been used for purposes other than those for which the machine was intended.

## DISCLAIMER OF IMPLIED WARRANTIES & CONSEQUENTIAL DAMAGES

Belco Resources Equipment obligation under this limited warranty, to the extent allowed by law, is in lieu of all warranties, implied or expressed, including implied warranties of merchantability and fitness for a particular purpose and any liability for incidental and consequential damages with respect to the sale or use of the items warranted. Such incidental and consequential damages shall include but not be limited to: transportation charges other than normal freight charges; cost of installation other than cost approved by Belco Resources Equipment; duty; taxes; charges for normal service or adjustment; loss of crops or any other loss of income; rental of substitute equipment, expenses due to loss, damage, detention or delay in the delivery.

## REGISTRATION

The online Warranty Registration must be completed in order to qualify for coverage on this Limited Warranty. Visit [br-equipment.com](http://br-equipment.com), click on "Warranty Registration" and completely fill out the form to register the new piece of equipment.

**Page left blank intentionally**



401 Jeffreys Road  
Rocky Mount, NC 27804  
[www.br-equipment.com](http://www.br-equipment.com)

Tel: 252-822-7140  
Fax: 252-787-5855  
[Sales@br-equipment.com](mailto:Sales@br-equipment.com)