

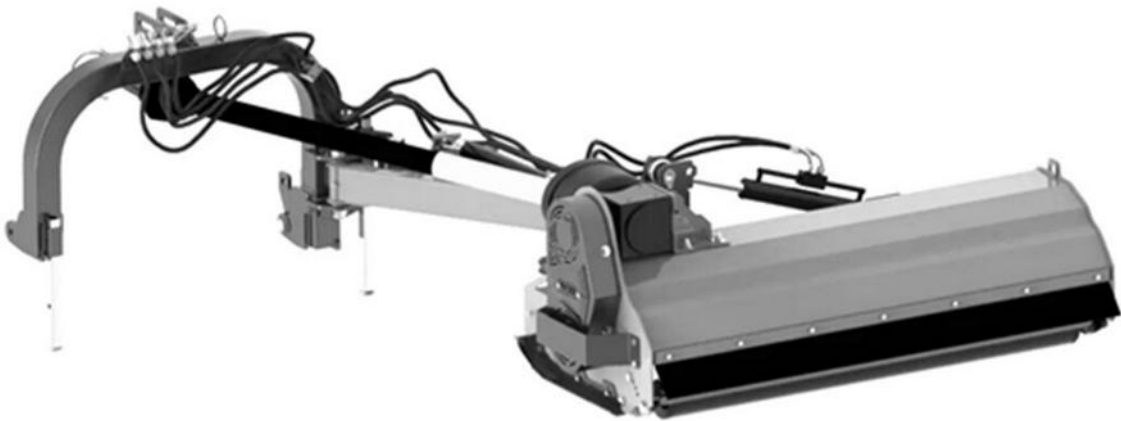

## Operator's & Parts Manual



FLAIL MOWER  
**Sabre 51**

**Sabre 61**

**Page left blank intentionally**

**Page left blank intentionally**



**CAUTION!**

Before using the machine, please read thoroughly this Instruction Manual and observe the safety instructions contained herein.

**The instructions manual is a part of the basic equipment of the machine!**

Keep the manual in a safe place, where it is available to the user and service technician through the entire life cycle of the machine.

In the event of its loss or damage, the user must acquire a new copy from the machine dealer or manufacturer.

In the event the machine is sold or made available to another user, the Instructions Manual must be attached with the declaration of conformity for the machine.

The manufacturer reserves its copyrights to the manual.

Copying, processing of the Instructions Manual and its parts without the manufacturer's permission is strictly prohibited

The manufacturer guarantees efficient operation of the machine, provided it is used in accordance with the technical and operating conditions specified in this INSTRUCTIONS MANUAL.

All faults revealed during the warranty period will be repaired by the Warranty Repairs Service. The expiration date of the warranty period is specified in the WARRANTY CARD.

The warranty does not cover parts and components of the machine subjected to wear and tear under normal operating conditions regardless of the warranty period, i.e.: bearings, cutting blades/hammers, aprons/protective covers, hydraulic hoses, etc.

The Warranty Service covers only instances such as: mechanical damage not caused by a fault of the user, production defects, etc.

If any damage results from:

- mechanical damage caused by a fault of the user or a traffic accident,
- improper use, adjustment and maintenance, use of the machine for a purpose other than intended,
- operating a damaged machine,
- repairs conducted by unauthorized persons or improper repairs,
- unauthorized changes to the machine structure,

the user may invalidate its rights to the In-Warranty Services.

The user is obliged to immediately report all identified faults and have them repaired, regardless of whether the damage is covered by the warranty or not. Special warranty terms and conditions are laid out in the WARRANTY CARD attached to the newly purchased machine.

**Table of Contents.**

- 1. Machine identification .....8
- 2. Introduction .....9
  - 2.1. Read the instructions manual .....9
  - 2.2. Intended use of the machine .....9
  - 2.3. Warranty ..... 10
- 3. Occupational health and safety technique ..... 10
  - 3.1. Basic safety principles ..... 10
  - 3.2. Safety signs on the machine..... 12
  - 3.3. Hazards in operating the flail mower ..... 14
  - 3.4. Transport ..... 16
  - 3.5. Working elements of the machine ..... 16
  - 3.6. Machine suspended on a three-point hitching system ..... 16
  - 3.7. Machine disconnected from the tractor ..... 16
  - 3.8. Work with jointed-telescopic shaft ..... 16
  - 3.9. Operation ..... 17
  - 3.10. Technical specification ..... 18
  - 3.11. Design and operation ..... 20
- 4. Operation ..... 21
  - 4.1. Working position. .... 23
  - 4.2. Transport position. .... 24
  - 4.3. Mowing height adjustment using the running shaft ..... 26
  - 4.4. Operation ..... 27
- 5. Recommended machine operation ..... 28
  - 5.1. Oil change points ..... 28
  - 5.2. Lubrication points ..... 28
  - 5.3. Tensioning of the V-belts ..... 29
  - 5.4. Changing cutting tools ..... 32
- 6. Technical inspections, storage, disposal ..... 33
  - 6.1. Storage ..... 34
  - 6.2. Dismantling and disposal ..... 34

6.3.	Stability .....	34
7.	Spare parts catalog .....	35
7.1.	General design .....	36
7.2.	Drive system .....	38
7.3.	Hitch suspension system .....	40
7.4.	Rear curtain .....	42
7.5.	Running gear .....	43
7.6.	Work assembly .....	44
7.7.	Right slider .....	45
7.8.	Left slider .....	46
7.9.	Hydraulic system .....	47
7.10.	Belt transmission shield .....	48
7.11.	Front curtain.....	50
7.12.	Other .....	51
7.12.1.	Turntable buffer .....	51
7.12.2.	Lubricator cover assembly .....	51
8.	Warranty .....	52

## 1. Machine identification

All the information required for identification is provided on a nameplate attached to the body of the machine. It contains information such as: the name and address of the manufacturer, the year of manufacture, the serial number, the weight of the machine.



**Figure 1.** Nameplate

If in doubt, any information about the machine and explanations of the instruction manual should be provided by the dealer or distributor.

### **Distributor Address**

#### **Belco Resources Equipment**

401 Jeffrey's Road  
Rocky Mount, NC27804  
Tel.: (252) 822-7140  
e-mail: [sales@br-equipment.com](mailto:sales@br-equipment.com),  
website: [www.br-equipment.com](http://www.br-equipment.com)

## 2. Introduction



### CAUTION!

This symbol warns of a hazard. The warning symbol indicates an important hazard information given in the Instructions Manual. Please read the notice, follow the instructions it specifies and take special caution.

### 2.1. *Read the instructions manual*



### CAUTION!

Read the instructions manual  
before use

**The Instructions Manual belongs is a part of the equipment of the machine. Make sure that you have become thoroughly familiar with its content before starting any works with the machine.**

This manual provides the user with information regarding operation, use and maintenance of the machine. It contains performance characteristics, requirements for safe and correct operation of the machine, allowing it to be used in the best possible way while retaining the maximum service life and reliability. Careful reading of the instructions manual will help to avoid accidents and enable long and trouble-free operation.

### 2.2. *Intended use of the machine*

The machine is designed for use in the vicinity of roads and for standard agricultural use, i.e. for mowing and shredding of short-stem plants (bushes, plant stems, etc.).

Using the mower for other purposes will be considered as unintended use,

which excludes the manufacturer's liability for the resulting damage.

- The machine can be operated only by persons who have been properly trained and made themselves familiar with the instructions manual and hold the required licence to drive the vehicle coupled with the machine.
- The mower should be used in accordance with its intended use and should be maintained and repaired correctly.
- Observe the safety regulations provided in this manual, general occupational health and safety rules and traffic regulations.

- Observe the occupational health and safety rules while operating and maintaining the machine.
- Any unauthorized modifications made to the machine exclude the manufacturer's liability for any resulting damage.

### 2.3. **Warranty**

The warranty terms are provided in the warranty card. The operator of the machine is obliged to get thoroughly familiar with this instructions manual. Failure to adhere to the correct operation rules leads to decreased efficiency of the mower, its breakdowns and loss of the warranty rights. The warranty rights will become invalid particularly if:

1. Mechanical damage caused by operation not in accordance with the instructions manual is found.
2. Repairs are carried out by workshops other than the seller's service station, the manufacturer's service station or service stations recommended by them.
3. Spare parts other than the genuine spare parts of the manufacturer have been used.
4. Unauthorized modifications of the design of the mower are prohibited.

## 3. Occupational health and safety technique







Most accidents which happen at work, during operation or transport result from failure to observe the basic safety principles. Therefore, it is important that every person in contact with the machine observes the basic safety rules referred to below in the strictest manner possible:

### 3.1. **Basic safety principles**

1. In addition to the recommendations contained in this manual, also observe the general occupational health and safety rules!
2. Follow the indications of warning inscriptions and symbols provided on the machine. This is for your safety!
3. Use of the machine without the required safety shields is prohibited; replace the damaged shields using genuine spare parts.
4. Before starting work using the mower, wait until the tractor's PTO reaches its rated speed. Do not exceed 540 rpm.
5. Any work on the machine while moving parts are rotating is prohibited, it is essential to wait until said parts have stopped. Never wear clothing which might become entangled in/by the rotating elements.
6. Never leave the mower running and unattended.
7. Before starting the mower or while operating it, make sure that there are no persons or animals within the hazard zone. **Operation of the mower with bystanders present within a distance smaller than 165 feet away is prohibited!**

8. It is forbidden to climb up the machine.
9. Fields, meadows and roadsides should be cleared of stones and hard objects – larger stones need to be removed.
10. Do not operate the mower while driving in reverse.
11. It is forbidden to step between the tractor and the machine before it has been secured against rolling away. This should be done by applying the parking brake on the tractor or by putting chocks under the running wheels.
12. The hydraulic lift lever of the tractor should be controlled only from the driver's seat position.
13. It is not permitted to operate the lifting and lowering lever from outside the vehicle.
14. It is forbidden to lift the machine on the hydraulic lift of the tractor with the drive turned on and the working shaft rotating.
15. Take special care when working on slopes and hillsides.
16. Do not use sagging, unbuttoned pieces of clothing during work, fitting, adjustments, dismantling. Keep such clothing elements away from components that can catch them.

### 3.2. Safety signs on the machine

 <p>Prior to using the machine, read the User Manual</p>	 <p>Switch off the engine and remove the key before carrying out maintenance or repair work</p>	 <p>Keep a safe distance from the machine. Do not allow bystanders to be within less than 165ft away</p>
 <p>Warning, belt transmission. Use extreme caution. Drawing-in of hand and arm.</p>	 <p>Warning, possibility of being drawn-in by the machine</p>	 <p>Keep a safe distance from the machine. Crushing of toes or foot – Force applied from above</p>



Do not travel on platforms or ladders.



Do not stand near tractor hitches while operating the lift.



Do not open or remove the guards with the engine running

**16 MPa**

Warning message about pressure in the hydraulic system.



Keep clear of pressurised liquid leaks



Caution - Mowing blades. Keep clear of the mower in operation





Mower handles for use during transport



Wear a protective suit



Wear safety goggles

 <p>Use hearing protectors</p>	 <p>Wear protective gloves</p>	 <p>Do not exceed the maximum speed</p>
 <p>Oil change point</p>	 <p>Lubrication point</p>	

### 3.3. Hazards in operating the flail mower

No.	Risk	Hazard source (cause)	Risk preventive measures
1	Overloading the loco motor system (physical load)	Working in a standing position, inclined-forced position, walking, moving objects	Read and understand the Instructions Manual; do workplace training in carrying weights standards for the manual handling, correct methods of lifting and carrying loads, getting other
2	Fall on the same level (tripping, slipping, etc.)	Uneven terrain, messy environment - objects lying and standing around, cables lying on communication roads, slippery	Suitable footwear, leveled surface, maintaining caution, maintaining order, familiarizing with the instruction manual
3	Hitting protruding parts of the machine	The machine and its surroundings	Proper positioning of a machine, safe space to move around, proper organization of work, paying attention, reading the
4	Struck by moving objects	Crushed plants, incidental part of the turf, stones thrown out by the machine	Instructions Manual Maintaining caution, marking out the danger zone, prohibiting walking around the working machine, prohibiting being at a distance of less than 50m from the working machine, use of personal protective equipment - helmet, safety glasses, reading Instructions Manual
5	Sharp, dangerous edges	Protruding parts of the machine structure, use of hand tools	Personal protective equipment – safety gloves, buttoned up work clothes, exercising special attention
6	Belt transmission systems	Fast moving transmission pulleys and belts, rotating jointed telescopic shaft, no covers on the movable parts	Prohibition of moving, approaching and making adjustments on the running machine, exercising caution, using shields of moving parts, reading the instructions manual
7	Oil-filled mechanical transmissions, hydraulic transmission systems	Fluids, hydraulic and lubricating oils, greases, temperature, leaks, slipping, burns, injections, sensitization, poisoning	Extreme caution, use of personal protective equipment - safety shoes, gloves and goggles, safe positioning of the machine. Familiarization with the user manual. Familiarization with the material safety data sheets for oils and lubricants used in the operation of the machine.
8	Weight of the suspended stationary machine	Improper mounting or coupling, wrong position of the machine, improper operation, leaving the suspended machine on a tractor	Exercising special attention, use of personal protective equipment - safety footwear, safety gloves, secure position of the machine, help of others, use of lifting jacks and hoists, reading the Instructions Manual
9	Micro climate - variable weather conditions	Work carried out in varied weather conditions	Suitable working clothes, beverages, creams with sun screens, proper rest, reading the Instruction Manual
10	Noise	Excessive rotational speed of the machine, damaged, loose, vibrating parts	Operation of the machine in good technical condition, inspections on a regular basis, proper rotational speed, reading the Instruction Manual
11	Thermal hazards	Contact with heat source radiation. Engine cooling systems, engine exhaust system. Temperature of the hydraulic system. Fire caused by sparks ejected upon collision with stones and other items encountered along the machine's path of operation	Use of personal protective equipment, familiarization with the instruction manual, special care. Temperature control of operating systems of the machine and the vehicle. Use of fire protection measures - essential vehicle/carrier equipment.

### 3.4. **Transport**

- Before the mower suspended on the tractor is set into the transport position, make sure that PTO is off and all rotating elements are at rest.
- Take special care while driving on public roads with the machine attached and follow the mandatory regulations of the highway code. In addition, a portable light-warning device and a warning triangle distinguishing slow-moving vehicles should be affixed during transport.
- Adjust your travel speed on the roads to current road conditions and according to common sense.
- Be aware that the machine extends beyond the outline of the tractor while traversing bends.

### 3.5. **Working elements of the machine**

- Before using the mower, pay attention to the condition of attachment of the cutting elements.
- Worn and damaged cutting elements and their attachments must be replaced immediately with original spare parts.

### 3.6. **Machine suspended on a three-point hitching system**

- Before suspending on or removing the mower from the three-point hitching system of the tractor, set the hydraulic lift lever in a position preventing unintended lifting or lowering of the machine.
- The categories of the tractor hitching system and that of the machine must be compatible.
- While the machine is in the transport position, always pay attention to the side stability of the connection between the tractor and the mower.
- While the machine is transported in the raised position, the hydraulic lift control lever must always be secured against lowering.

### 3.7. **Machine disconnected from the tractor**

Park the machine on a stable and even substrate, in a place protected from the weather and from outsiders.

### 3.8. **Work with jointed-telescopic shaft**

- Use only jointed-telescopic shafts supplied by the machine manufacturer or with similar characteristics.
- All installed shields of the jointed-telescopic shaft must be in good condition. Immediately replace the shaft shields when damaged.
- Install and remove the jointed-telescopic shaft only when the power transmission shaft is off, the motor is off and the key is removed from the ignition switch!

- Always make sure that the jointed-telescopic shaft halves overlap in the working position and the transport position as required by the regulations!
- Secure the shaft shield with a chain to prevent it from rotating with the shaft!
- Before turning on the power transmission shaft, make sure that the direction of rotations and the rotational speed of the power transmission shaft are compatible with the power take-off shaft rotations.
- Before turning on the power transmission shaft, make sure that no one is present nearby, within hazardous distance from the machine.
- Turn off the jointed-telescopic shaft when its operation is not necessary.
- After turning off the power transmission shaft, wait for the inertial rotation of the rotating weights to stop before anyone enters the hazardous zone.
- After disconnecting the jointed-telescopic shaft, slide on the shields again and put the shaft away in the designated location.
- If damage has occurred, it must be repaired immediately or the shaft replaced with a new one.

### 3.9. **Operation**

Carry out all repairs, maintenance and adjustments only with the drive disconnected, the engine switched off and the ignition key removed. Pay special attention to the hazards present while the machine is being switched from the working position to the transport position.



Use protective clothing and gloves while carrying out maintenance works - especially while replacing cutting elements!



It is forbidden to operate the machine on edges of streets, roads, public squares (parks, schools etc.) or stony terrain to avoid the hazard related to the stones and other objects being thrown.



All labels applied onto the machine must be legible. If any of the labels becomes damaged, the owner / user is obliged to replace it with a new one.

### 3.10. *Technical specification*

TYPE	Sabre-51	Sabre-61
Power requirement	min 20 HP, max 40 HP	min 25 HP, max 45 HP
TPH category	I	I
Weight	251 kg [553 lbs.]	266 kg [586 lbs.]
Number of hammers	32	40
Working speed	3-5 km/h [2-3 mph]	3-5 km/h [2-3 mph]
Transport speed	up to 20 km/h [12 mph]	up to 20 km/h [12 mph]
Power take-off speed of the vehicle	540 rpm	540 rpm
Operating width[A]	1300 mm [51"]	1550 mm [61"]
Dimension[B]	527 mm [21"]	
Dimension [C]	670 mm [26"]	
Dimension [D]	1556 mm [61"S]	1806 mm [71"]
Dimension [E]	1265 mm [50"]	
Dimension [F]	90°	
Dimension [G]	50°	
Dimension [H]	825 mm [32"]	
Dimension [I]	1160 mm-1195 mm [46"-47"]	
Dimension [J]	850 mm [33"]	
Dimension [X]	110 mm [4"]	

**\*The weight of the tractor coupled to the machine is important. In connection with this parameter follow Chapter 6.3 Stability.**

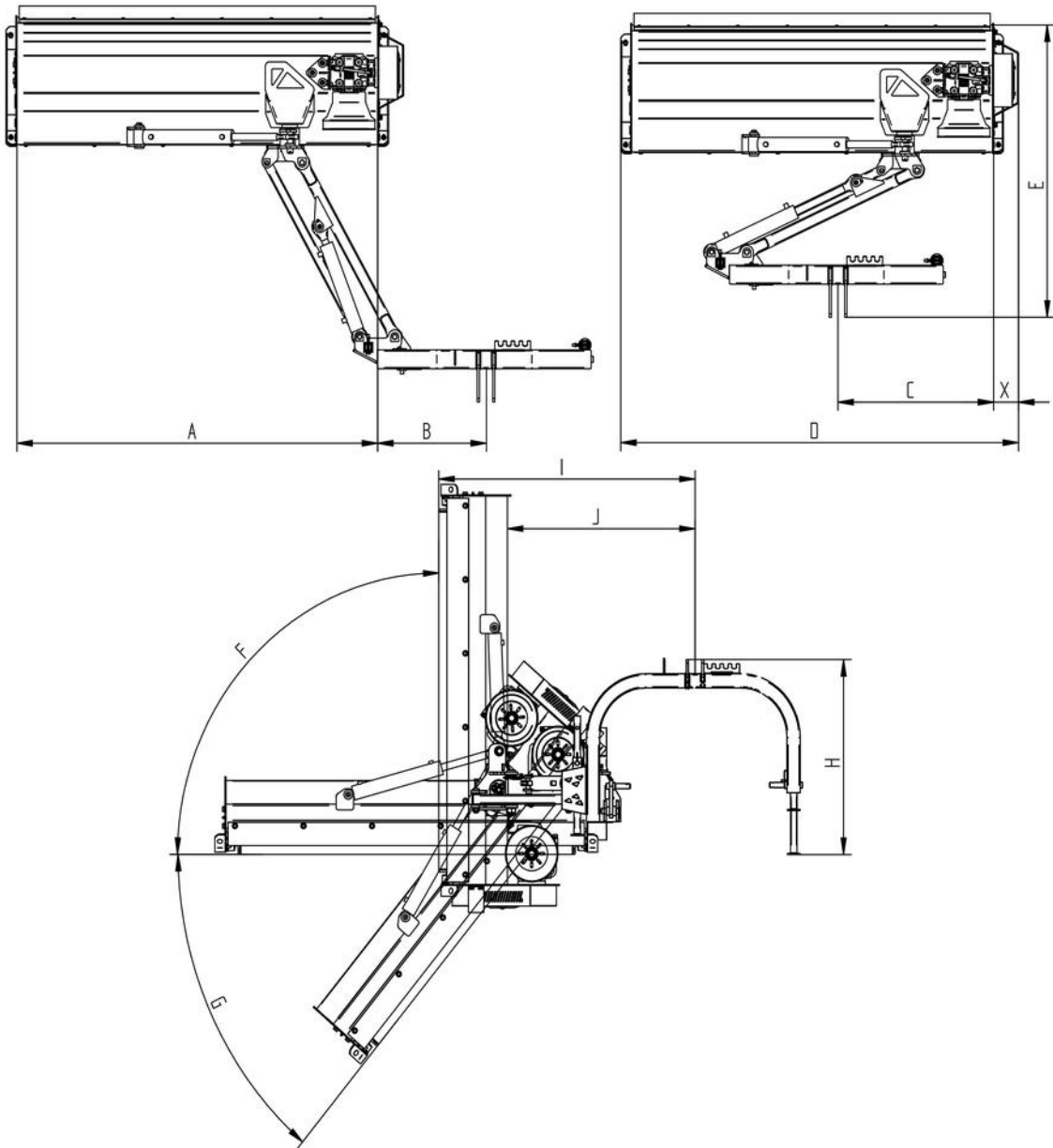

**Figure 2.** Basic dimensions

### 3.11. Design and operation

The machine shown allows work to be carried out on the rear of the tractor. A suspension system (3) allows the machine to be connected to the tractor. The jointed-telescopic shaft is responsible for transmitting the drive to the drive system (2). The main components of the drive system are the angular gearbox and belt transmission, which transmits the drive to the working shaft (6) embedded in the body (1). The entire machine travels on the ground on a jockey shaft (5), which is also referred to in the manual as a running shaft. In addition, sliders (7,8) have been incorporated for better protection of the machine during operation and more comfortable use. A front curtain (11) and rear curtain (4) protect against ejected objects during mowing. A hydraulic system (9) is responsible for tilting the machine on inclines and in hard-to-reach places.

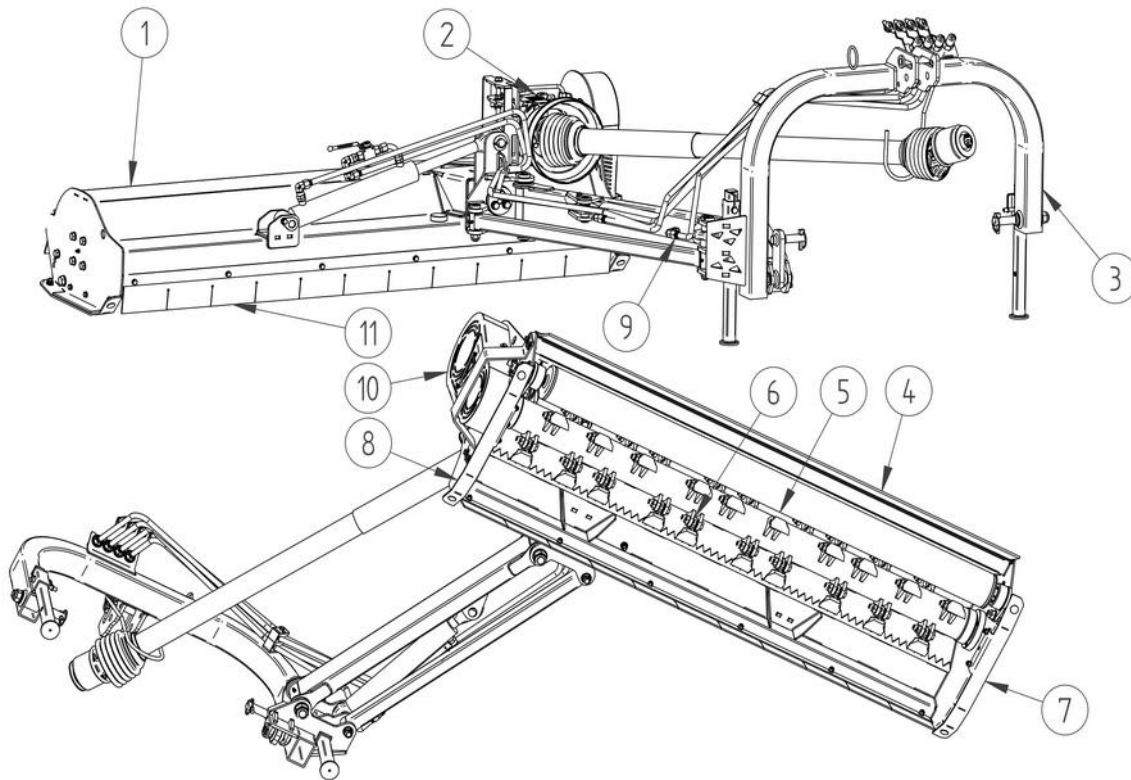
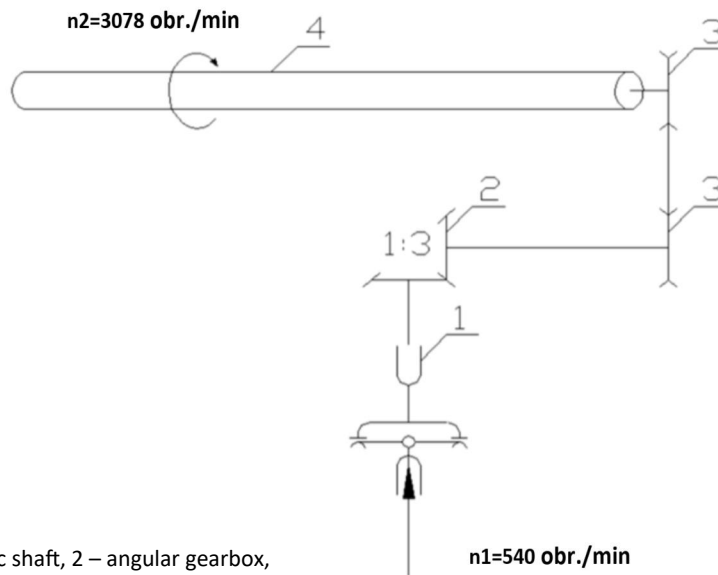

Figure 3. General design



1 - jointed-telescopic shaft, 2 – angular gearbox,  
3 – belt transmission, 4 – working shaft.

Figure 4. Drive diagram

## 4. Operation

The manufacturer guarantees that the machine is fully operational and has been checked in accordance with quality control procedures and approved for use. However, this does not relieve the user from the obligation to inspect the machine after its delivery.

**Before every time the mower is used, its mechanical condition needs to be checked, and especially the condition of cutting unit, drive transmission system, hydraulic system and guarding shields.**



**The machine can be started once it is supported on the ground. It is prohibited to engage the drive when the machine is raised above the working surface and not resting on the ground. It is prohibited to lift a running machine on a hoist. Disconnect the drive and wait until rotation stops before lifting the machine.**

## I. Coupling the suspension system of the vehicle and the machine.

- The machine is mounted on a three-point hitch suspension system of the tractor. Before coupling, position the lower attachment as shown in the drawing below. The component shown tilts the machine when it encounters an obstacle.

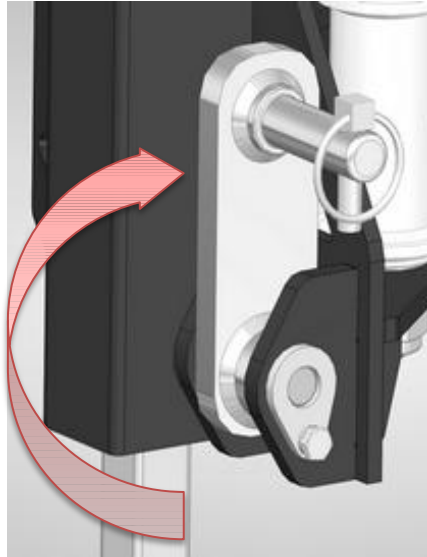

**Figure 5.** Positioning of the lower attachment during coupling.

- During operation, a correctly adjusted central link is important. This is indicated by the sliders, which should be parallel to the ground.
- Each time the mower is mounted on the vehicle, check the connecting elements, i.e. pins and plugs, for wear. In case of wearing out replace them with new ones.



**Take special care that no-one is in the area between the machines when coupling the machine and the tractor.**

## II. Connecting the drive shaft of the machine.

- Once the machine is mounted on the three-point linkage, the jointed-telescopic shaft must be fitted.

- Pay particular attention to the correct installation of the shaft and its securing. Follow the instructions supplied with the shaft. Carry out all operations such as correct cutting and lubrication in accordance with the instructions.

### III. Connecting the power hydraulic system.

- The machine is equipped with two double-acting cylinders.
- When connecting the hydraulic lines, make sure that the hydraulic system is not pressurized
- The hydraulic lines are marked with two colors Each color corresponds to one cylinder.
- Ensure that the cylinders are controlled correctly before proceeding.
- Each time before work, pay attention to the condition of the cables and connections. Replace all defective system components with new ones. If leaks occur, the condition of the connections should be checked.
- The hydraulic system is pressurized and should therefore be handled with extreme care.

#### 4.1. ***Working position.***

Before starting work, the machine must be properly prepared and set up:

- The central link (A) should be set in the middle position of the longitudinal hole, the machine should rest on the running shaft, while the sliders (B) should be set relatively parallel to the ground. Once adjusted, raise both support feet (C,D).

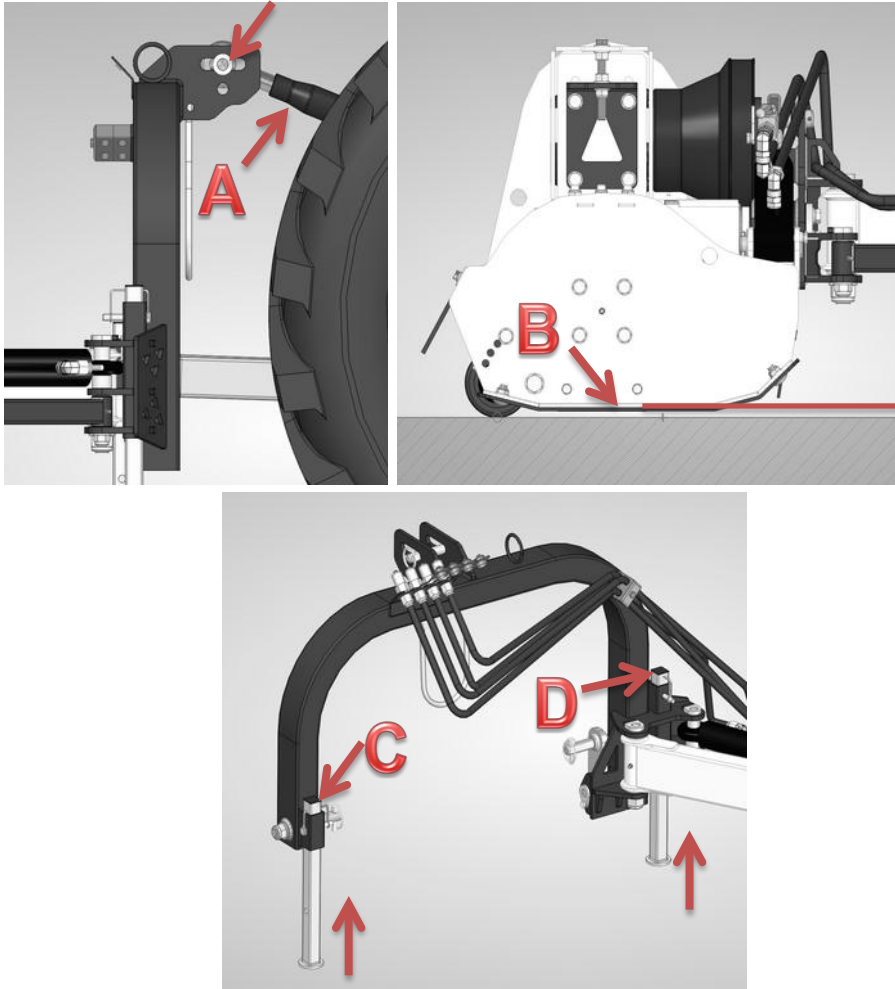

**Figure 6.** Working position

It is also important to ensure that the ball valve is correctly positioned on the actuator during operation and transport of the machine. The correct valve setting is shown in Figure 8.

It is vital that the PTO shaft length is correctly selected. If the shaft is too long, it should be shortened according to the instructions supplied with it.

#### 4.2. ***Transport position.***

Before transporting the machine, the following actions must be performed:

- If the machine has been used, it is necessary to wait until the rotation of the working shaft due to its inertia has stopped.

- Place the central coupling pin (A) in the transport hole shown in Figure 7. In addition, fold the machine into the position shown in the view below.

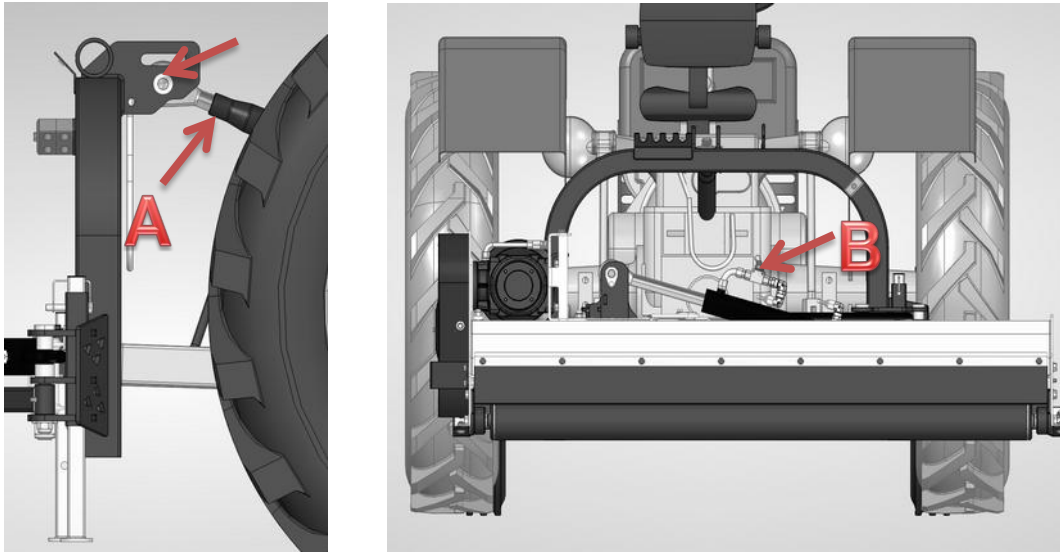

**Figure 7.** Setting the machine for transport

- If the mower has been fitted with a ball valve on the cylinder, it is important to ensure that it is correctly adjusted during transport and operation. During transport, the valve must always be in the closed (OFF) position and during operation in the open (ON) position, as shown in Figure 8. A ball valve actuator is shown in Figure 7(B).

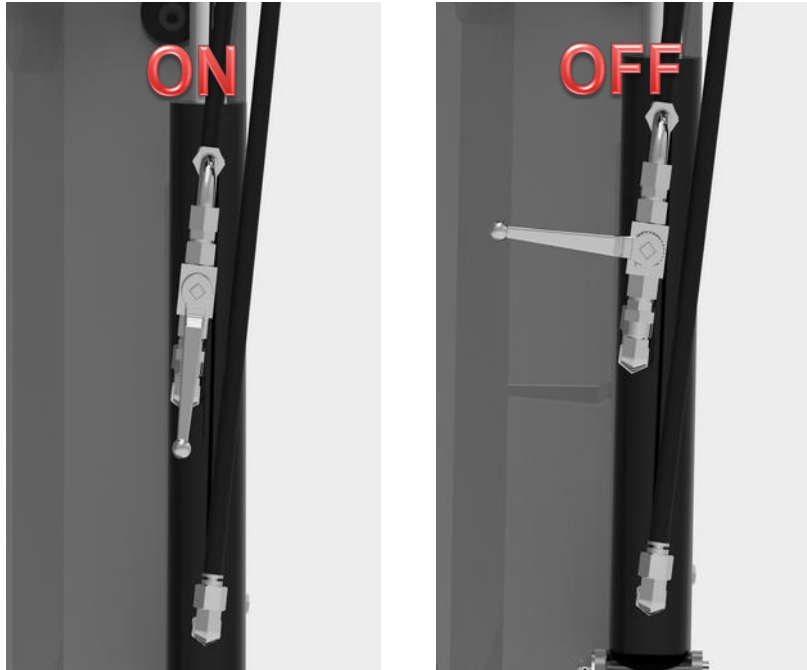

**Figure 8.** Position of ball valve during operation and transport

#### **4.3. *Mowing height adjustment using the running shaft***

Changing the cutting height requires a change to the position of the running shaft. In order to do this, lift the machine, secure it against falling and moving. The cutting height ranges from approximately 1.0" to 1.5". The shaft can be adjusted 4 stages by turning an M16 screw in 1 of the 4 holes. Start the adjustment by loosening the M16 screw marked "A" in Figure 9. The screw marked "B" must be unscrewed and inserted into the appropriate hole. The operations must be carried out on both sides of the shaft using the coaxial holes in both sides. When repositioning the screws, remember that the shaft will fall down under its own weight and that it is necessary to support it to ensure safe handling. Repositioning the screw by 1 hole results in a cutting height change of approximately 11 mm.

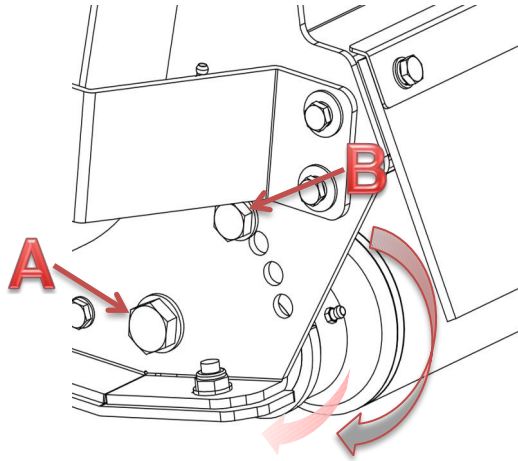

**Figure 9.** Driving shaft adjustment

-While switching the machine from the transport position to the working position and back, no one is allowed to stay in the zone of moving elements.



-When adjusting the machine, the tractor must be switched off, the ignition key removed and the parking brake applied.

#### 4.4. **Operation**



The machine can be started once it is supported on the ground. It is prohibited to engage the drive when the machine is raised above the working surface and not resting on the ground. It is prohibited to lift a running machine on a hoist. Disconnect the drive and wait until rotation stops before lifting the machine.

The operation speed depends on the field conditions and should be adapted to them to ensure satisfactory work quality.

It is also necessary to do the following each time before the work is carried out:

- Check the general condition of the machine
- Check the condition of the connections.
- Check the power hydraulic system for damage or leaks.

## 5. Recommended machine operation

### 5.1. Oil change points

Change the oil in the angular gearbox at least once a year. The quantity of oil to be changed and its specifications are shown below:

	Oil quantity	Oil specifications
Gearbox	1.5L	GL-4 80W90

The oil change points are marked in Figure 9, where “A” indicates the oil filling inlet and “B” the drain plug.

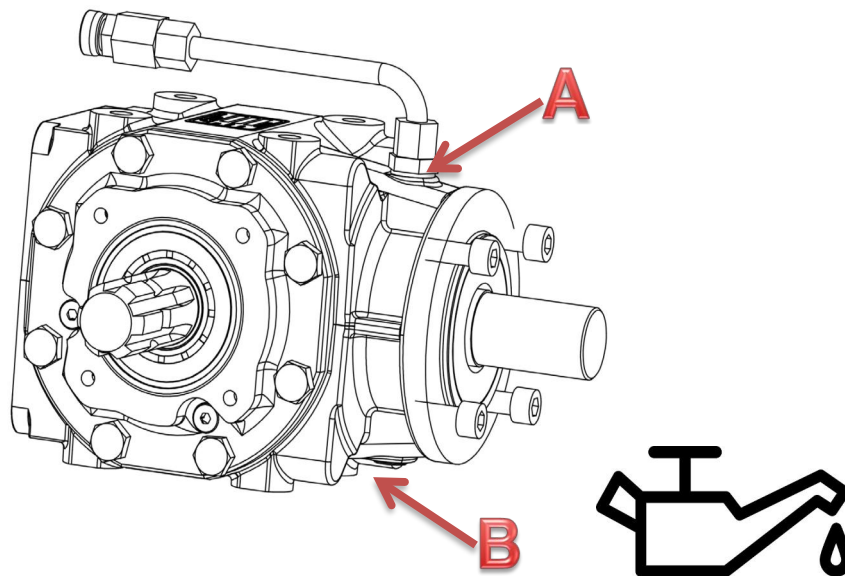

Figure 10. Oil change points

### 5.2. Lubrication points

To ensure the correct performance of the machine, it must be thoroughly and properly lubricated according to the lubrication diagram.

All points indicated in Figure 10, equipped with ball type grease fittings, should be filled with solid grease  $\epsilon$ T43 using of a lubricating gun. Lubricate the jointed-telescopic shaft after removing it from the machine. Lubricate the telescopic part of the shaft at least after 8 hours of operation – when the shaft is entirely moved apart and impurities have already been cleaned. Details of PTO shaft operation are contained in a separate manual supplied with it.

The figure 10 presents the location and recommended operating time after which the indicated components should be lubricated.

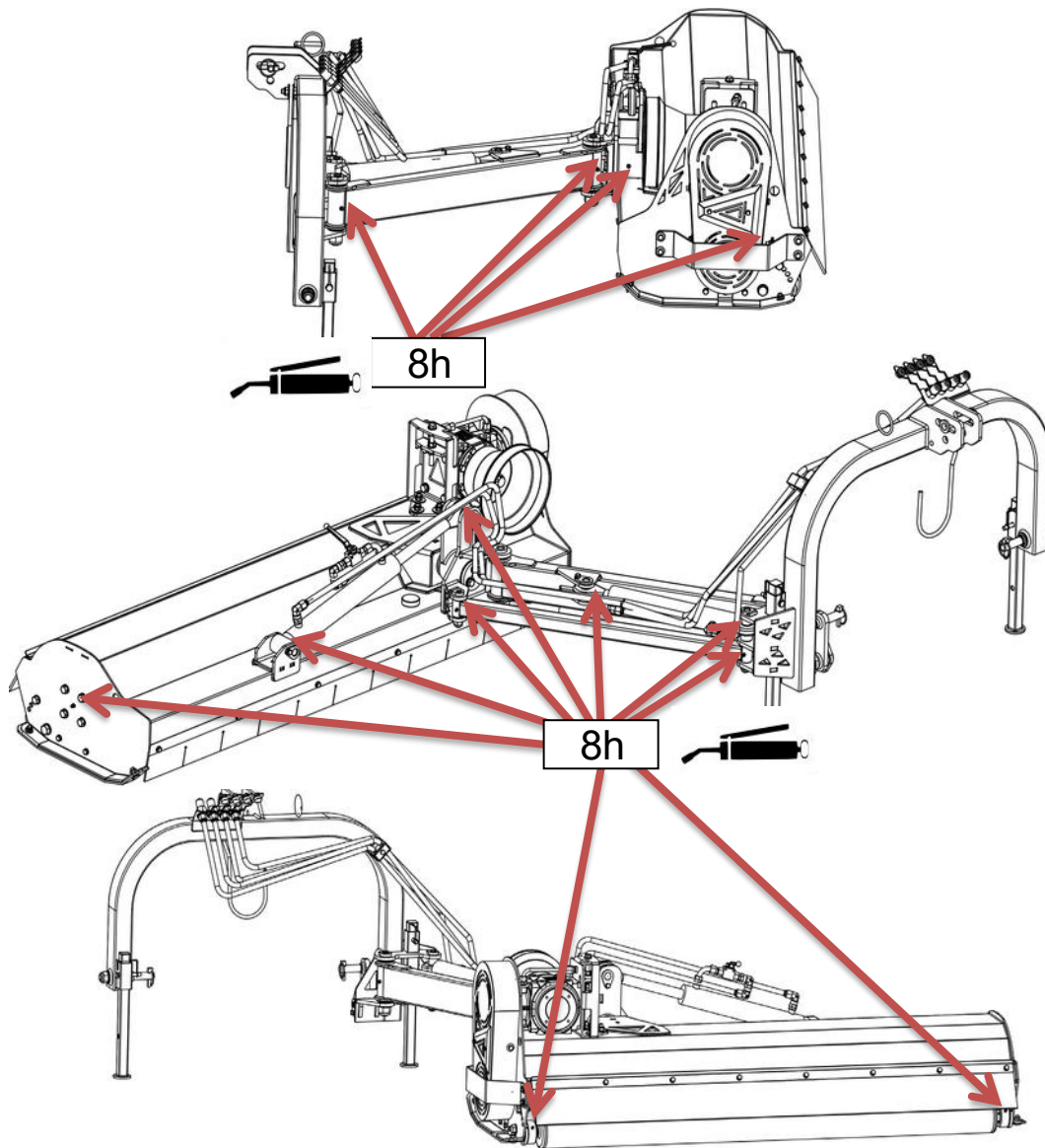

Figure 11. Lubrication diagram

### 5.3. *Tensioning of the V-belts*

To verify the belts, first remove the belt transmission shield (A), which is fixed with three M8 screws (C), or at least the sight glass (B) in the shield, fixed with two M6 screws (D). Correctly tensioned belts yield approximately 0.5" at a 5 kg (50 N) pressure, which is roughly equivalent to thumb pressure used if specialist belt tension gauges are not available.

If it is necessary to tighten the belts:

1. Remove the shield (A) and side slide (E). To do this, the M8 screws (D) holding the shield and the side slide must be removed.
2. The next step is to loosen the four M10 screws (F) holding the gearbox.
3. After loosening the gearbox bolts, loosen the M12 lock nuts (G,I) and the four M12 bolts (H) – remember to only loosen them, not unscrew them all the way. The belts are tensioned by turning the 13mm key-adjusted screw (K) and the M12 nut (J).
4. The direction of tension is indicated by a large arrow. It is important to remember the correct level of belt tension.
5. After verification of belt tension, inspect the alignment of the pulleys with a spirit level or other similar gauge and adjust if necessary.
6. Only after this is done can all bolts and nuts be tightened and the belt shield and slide be fitted.

Figure 12. Belt tensioning diagram

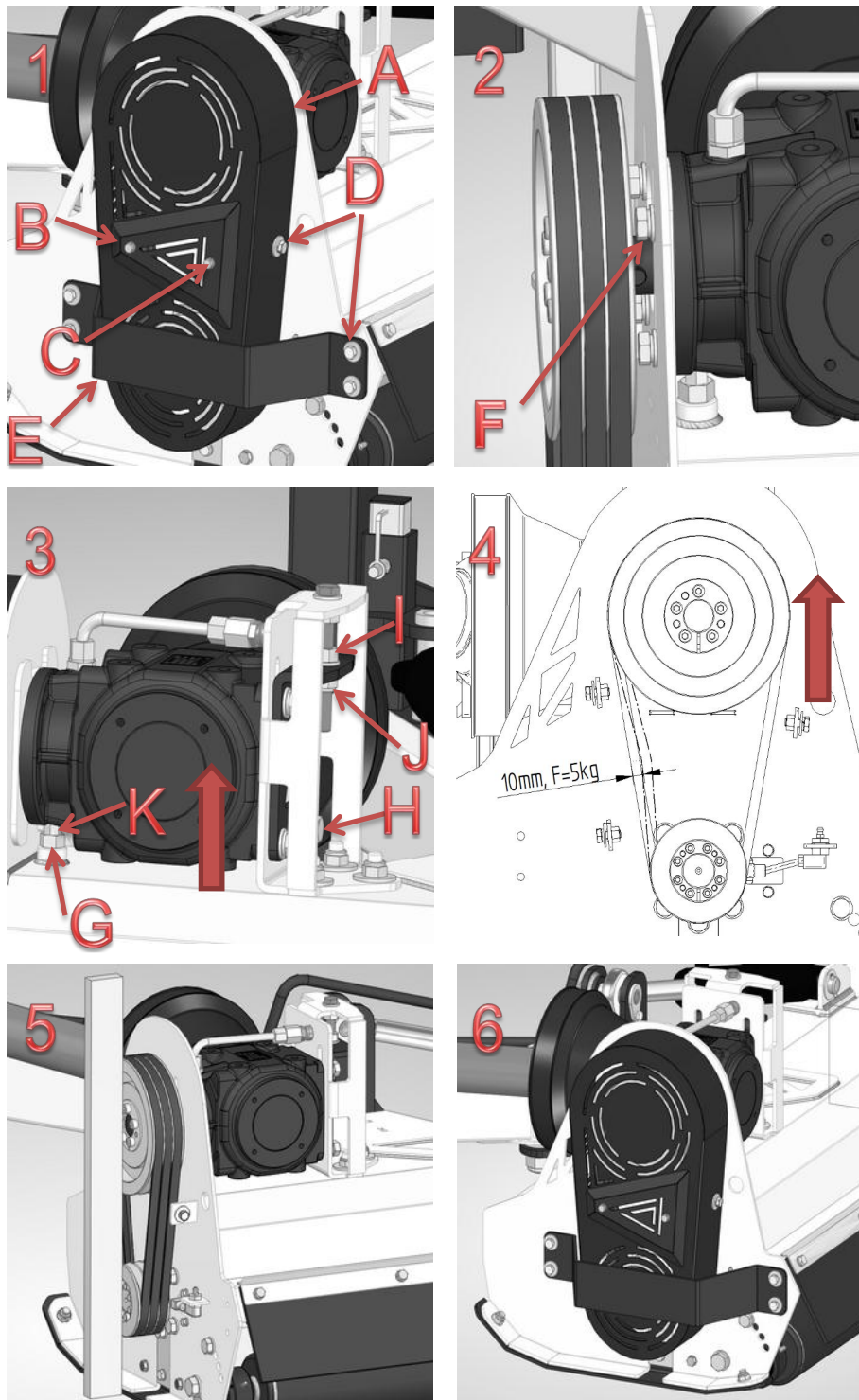

#### 5.4. Changing cutting tools

The working shaft is fitted with the appropriate cutting tools. These tools are shown in Figure 13, where the individual components are numbered:

- 1-Mounting on the working shaft welded to the shaft tube (non-replaceable part, only available as a whole shaft).
- 2-M14 self-locking nut (part no.: M1415)
- 3-washer (part no.: FZ10067)
- 4-M14x60 special bolt (part no.: FZ10066)
- 5-hammer (part no.: FZ10068)

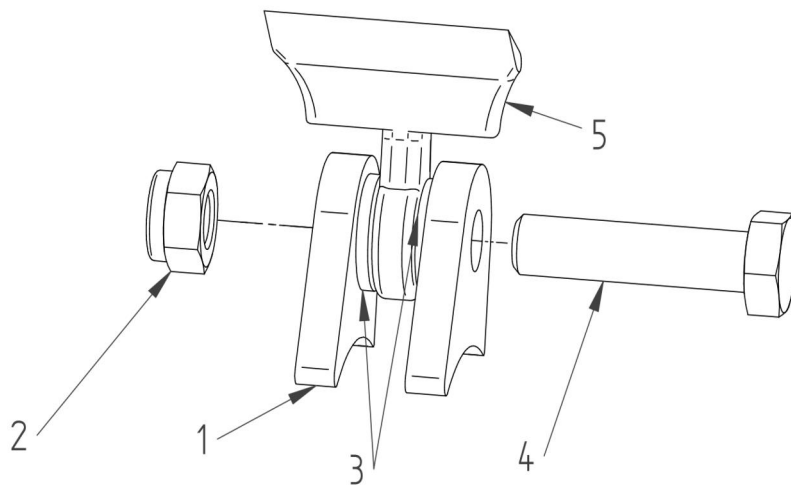

**Figure 13.** Cutting tool assembly

The cutting tools must be replaced if defects, noticeable signs of wear, blunting of the cutting edges, missing blades or flails, or excessive play of the mounted tools are identified.



#### Maximum cutting tool play

Play	Nominal [mm]	Permissible [mm]
	Flail	Flail
Transverse axial	0.5	1
Longitudinal axial	0.2	0.6

The cutting tools must be replaced in compliance with the specific safety rules.

1. Use only the original and functional parts for the cutting units.
2. Always replace full sets of tools. You must remember about the uniform distribution of the rotating masses, to ensure the uniform wear of the tools.
3. The bolted connections need to be replaced with new ones each time the tools are replaced, paying attention to the resistance class of the bolt and the self-locking nut.
4. When tightening the bolt connection, pay attention to the free (without excessive play) rotation of the cutting tool in relation to the bolt axis.

In addition, as part of the overall service:



- V-belts and hydraulic lines should be replaced every 5 years.
- Check the condition of the belts and bolted connections after approximately 5 initial hours of operation. Check the condition of the bolted connections every 10 hours of operation.
- Clean the machine after each working day, especially the lubrication points.

## 6. Technical inspections, storage, disposal

Every day, at the end of work, clean the mower carefully and check its technical condition. Pay special attention to the condition of the flails and knives. Damaged or worn parts must be replaced with new ones. Check all the bolted connections and tighten loose connections, according to the table of tightening torque values for bolts and nuts. In addition, use bolt glue to secure the working shaft to the body. If coating defects are identified, they should be remedied with a new coat of paint.

**Tightening torque values for bolts and nuts**

Strength Bolt class	6.8	8.8	10.9	12.9
Metric thread	Tightening torque [Nm]			
M6	7.2	9.5	14	16.5
M8	17.5	23	34	40
M10	35	46	68	79
M12	60	79	117	135
M14	95	125	185	215
M16	147	195	280	330
M18	202	280	390	460
M20	284	390	560	650
M22	385	530	750	880
M24	490	670	960	1120
M27	725	1000	1400	1650
M30	990	1300	1830	2200

COMMENTS:

## COMMENTS:

1. The table gives the maximum tightening torques (according to ISO 898/1) that bolts and screws should be able to withstand. No plastic unscrewing.
2. In the case of the use of lubricants or coatings that reduce the friction coefficient on the thread and under the bolt head, a tightening torque of 70% of that given in the table should be used.

### After the end of the operating season:

- carefully clean the machine,
- carry out technical inspection and replace the damaged parts with new ones available from the manufacturer,
- lubricate the machine according to the lubrication diagram (Fig. 11),
- remedy defects in the protective coating.



All repairs and replacements of parts of the mower drive system should be carried out by a proper workshop equipped with appropriate tools and instruments.

### 6.1. **Storage**

Store the mower in a dry place, sheltered from the weather.

The machine should be placed on a stable, level surface and protected against uncontrolled movement.

### 6.2. **Dismantling and disposal**

If the machine becomes worn to the extent which prevents its further use, it should be disposed of. This also applies to regular repairs and replacement of damaged parts. To do this, the machine must be thoroughly cleaned, its operating fluids removed and sent for disposal. Next, disassemble the machine by segregating its parts according to the materials used in them. The segregated parts should be taken to a recycling or a disposal center

### 6.3. **Stability**

In order to verify the overall stability, the following formula may be used to calculate the minimum additional front load  $f_{min}$  expressed in kg, enabling the front axle load equal to 20% of the tractor weight to be achieved.

$$I_{F,min} = \frac{[I_R \times (c+d)] - (T_F \times b) + (0,2 \times T_E \times b)}{a+b}$$

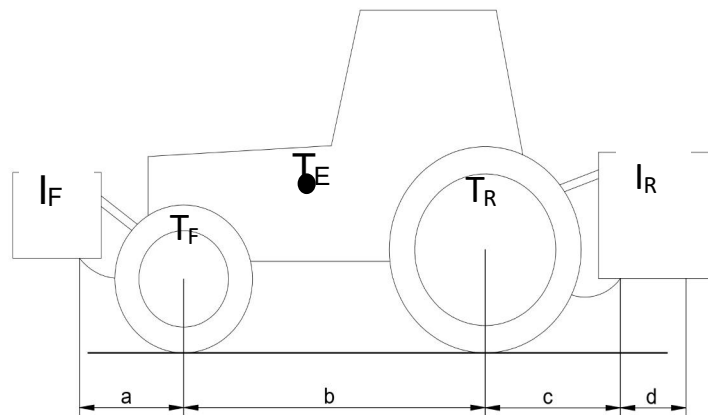

Explanations:

T<sub>E</sub>-empty tractor weight [kg]

T<sub>F</sub>-front axle pressure, empty tractor [kg]

T<sub>R</sub>-rear axle pressure, empty tractor [kg]

I<sub>F</sub>-weight of the machine hitched in the front/front weights[kg]

I<sub>R</sub>-weight of the machine hitched in the rear/rear weights[kg]

a-distance between the center of gravity of the front-hitched machine/front weights and the center of the front axle [m]

b-tractor wheelbase [m]

c-distance between the center of the rear axle and the centre of ball joints of the rear suspension [m]

d-distance between the center of the rear suspension ball joints and the center of gravity of the rear-hitched machine/rear weights [m]

## 7. Spare parts catalog

### SPARE PARTS ORDERING PROCEDURE

Each order form should include the following:

- address of the buyer;
- exact shipping address (place where machine is located or other means for delivery collection);
- terms of payment;
- serial number of the machine and the year of manufacture (acc. to the nameplate on the machine);
- spare part number;
- spare part name;
- number of parts ordered.

## 7. Spare parts catalog

### SPARE PARTS ORDERING PROCEDURE

Each order form should include the following:

- address of the buyer;
- exact shipping address (place where machine is located or other means for delivery collection);
- terms of payment;
- serial number of the machine and the year of manufacture (acc. to the nameplate on the machine);
- spare part number;
- spare part name;
- number of parts ordered.



Spare parts must be ordered at the points of sale of the machines or from the manufacturer. Use only the original spare parts provided by the manufacturer, to guarantee safe and reliable operation of the machine. The use of not original spare parts or parts, which have been repaired, will render the warranty void.

The manufacturer reserves the right to introduce changes to the design of parts presented in the particular assembly drawings in this spare parts catalog. Such changes may not always be updated in the manual and the spare parts catalog. Individual drawings may differ from the actual look of the parts.

### **Distributor Address**

#### **Belco Resources Equipment**

401 Jeffrey's Road

Rocky Mount, NC27804

tel.: (252) 822-7140

e-mail: [sales@br-equipment.com](mailto:sales@br-equipment.com),

website: [www.br-equipment.com](http://www.br-equipment.com)

## 7.1. General design

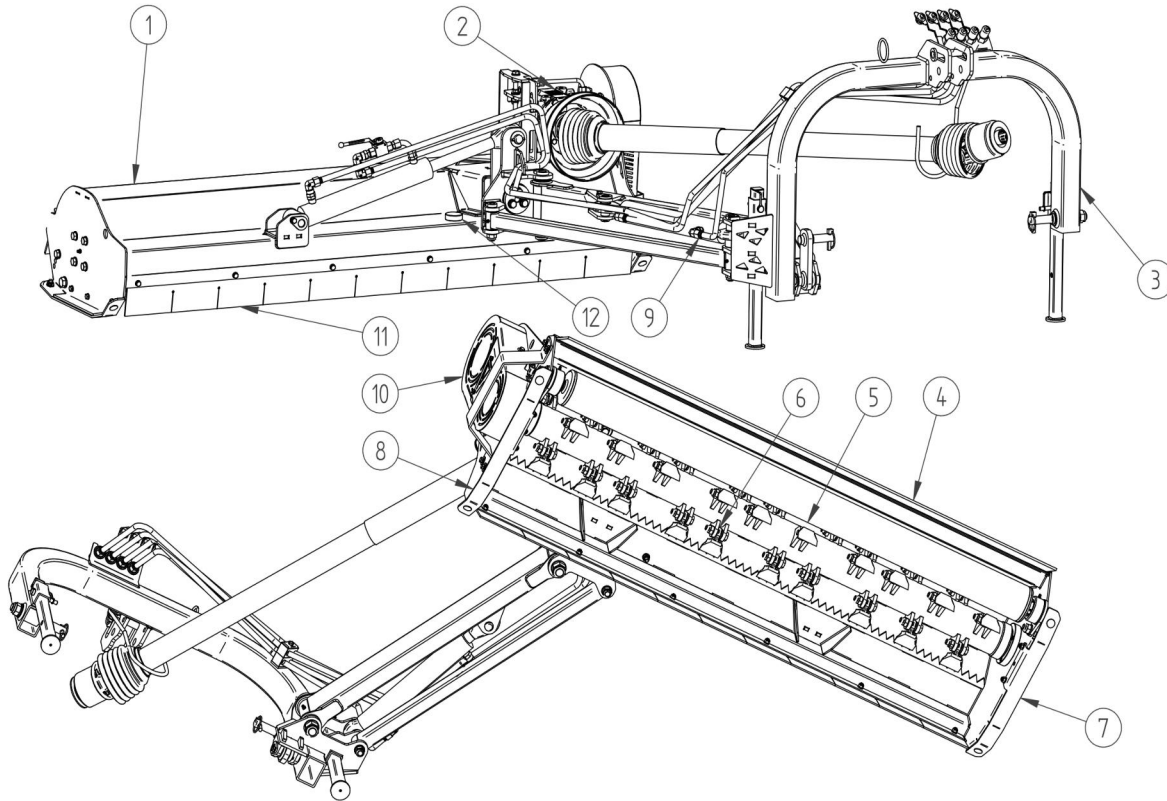

Item	Name	Index/Section	Qty	
1.	Body; Sabre-51	Sabre-51	FZ10001	1
	Body; Sabre-61	Sabre-61	FZ10002	1
2.	Drive system	Section 7.2	1	
3.	Hitch suspension system	Section 7.3	1	
4.	Rear curtain	Section 7.4	1	
5.	Running gear	Section 7.5	1	
6.	Work assembly	Section 7.6	1	
7.	Right slider	Section 7.7	1	
8.	Left slider	Section 7.8	1	
9.	Hydraulic system	Section 7.9	1	
10.	Belt transmission shield and side slide	Section 7.10	1	
11.	Front curtain	Section 7.11	1	
12.	Other	Section 7.12	1	

## 7.2. Drive system

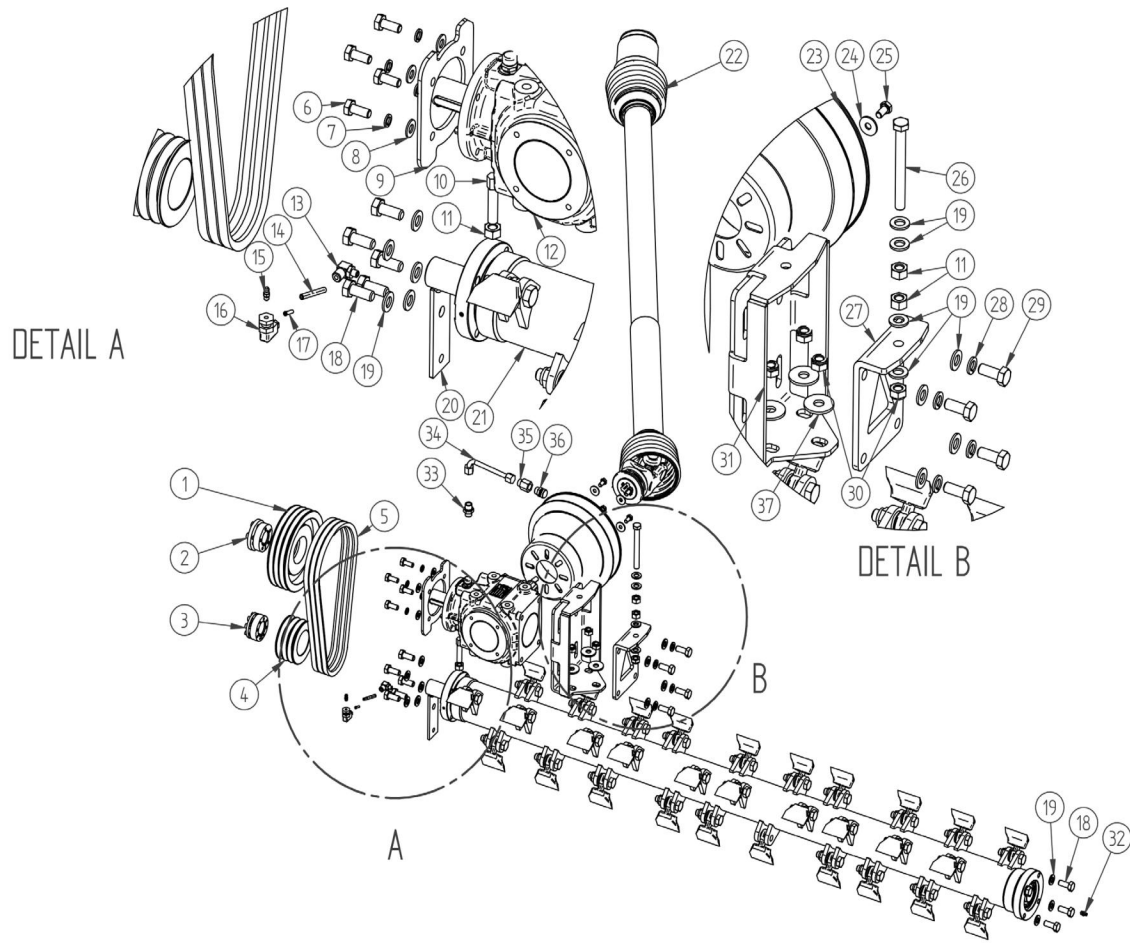

Item	Name	Index/Section	Qty
1.	SPA pulley, large	FZ10003	1
2.	RCK 15 33/65 coupling	FZ10004	1
3.	RCK 13 35/60 coupling	FZ10005	1
4.	SPA pulley, small	FZ10006	1
5.	XPA V-belt	FZ10007	3
6.	Bolt M10x30-8.8	BM1012530	4
7.	Spring washer M10	LW10	4
8.	M10 regular washer	FW10	4
9.	Gearbox cover	FZ10008	1
10.	Lifting bolt RBL	FZ10009	1
11.	Nut M12	NM12125	3
12.	Gearbox	FZ10010	1
13.	WEDK-6-M8x1 angle swivel coupling	FZ10011	1
14.	Polyamide cable 6x4	FZ10012	0.1
15.	Grease nipple M6x1	GN0610S	1
16.	Angled bulkhead connector	FZ10013	1
17.	6/4 brass sleeve	FZ10014	1
18.	Bolt M12x30-8.8	BM1212530	9
19.	M12 regular washer	FW12	17
20.	Working shaft cover	FZ10015	1
21.	Work assembly	NA	1
22.	Standard PTO shaft	FZ10016	1
23.	PTO guard	FZ10017	1
24.	Extensional washer M8	LFW08	4
25.	Bolt M8x16-8.8	BM0812590	4
26.	Bolt M12x90-8.8	BM1212590	1
27.	Gearbox tensioner	FZ10018	1
28.	Spring washer M12	LW12	4
29.	Bolt M12x35-8.8	BM1212535	4
30.	M12 self-locking nut	LN12125	4
31.	Gearbox base	FZ10019	1
32.	Grease nipple M8x1	GN081S	1
33.	Connector G3/8-M16x1.5 / connector M16x1.5 - M16x1.5 ED/10L	Straight FZ10020 FZ10021*	1
34.	Gearbox vent pipe	FZ10022	1
35.	Reduction M16x1.5-G3/8	FZ10023	1
36.	Air vent	FZ10024	1
37.	Extensional washer M12	LFW12	3

\*depends on the gearbox type used

### 7.3. Hitch suspension system

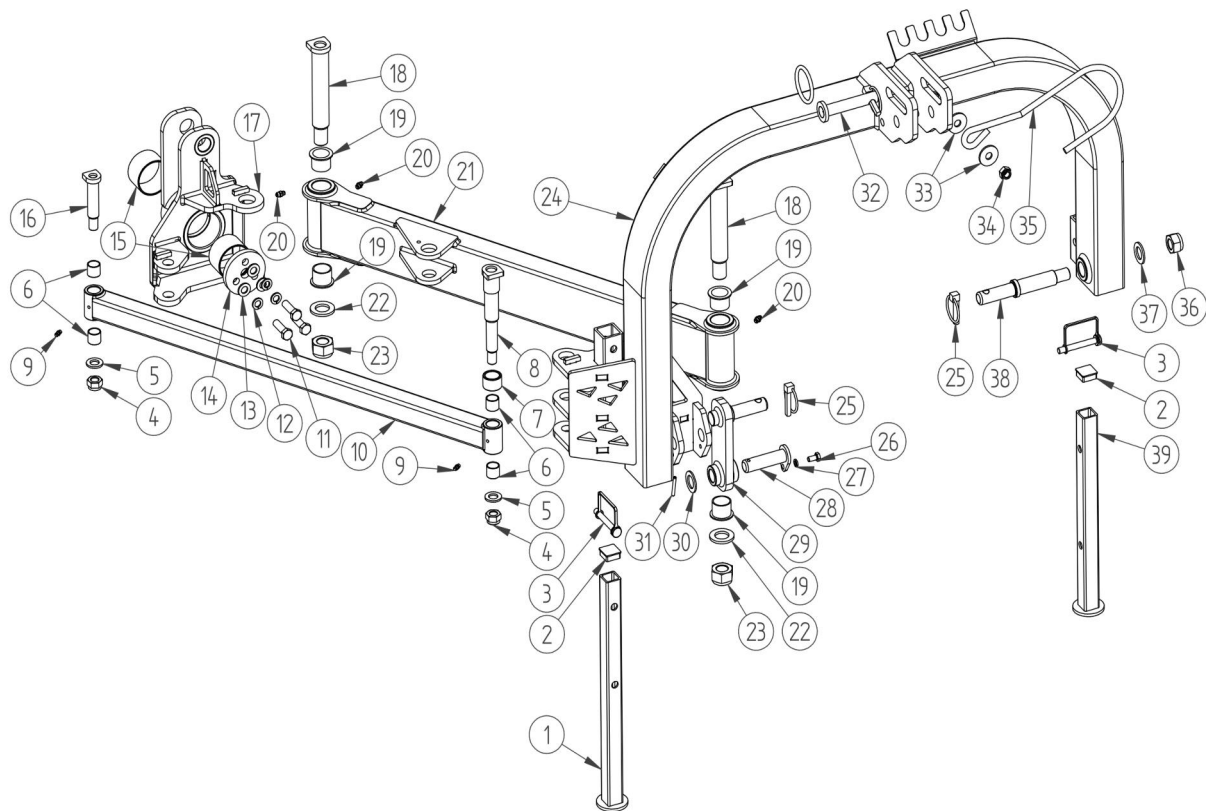

Item	Name	Index	Qty
1.	High support foot RBL	FZ10025	1
2.	Cap 30x30	FZ10026	2
3.	Folding pin LPS1267GP	FZ10027	2
4.	M16 self-locking nut	LNLM1615	2
5.	M16 regular washer	FW16	2
6.	Sliding sleeve 20X20	FZ10028	4
7.	Spacer bushing	FZ10029	1
8.	Composite pin	FZ10030	1
9.	Grease nipple M6x1	FZ10031	2
10.	Low arm	FZ10032	1
11.	Bolt M12x40-8.8	BM1212540	3

12.	Spring washer M12	LW12	3
13.	M12 regular washer	FW12	3
14.	RBL turntable safeties	FZ10033	1
15.	Bushing 60X40	FZ10034	2
16.	Low arm pin	FZ10035	1
17.	RBL turntable	FZ10036	1
18.	High arm pin	FZ10037	2
19.	30260 sliding sleeve	FZ10038	4
20.	Grease nipple M8x1	GN081S	3
21.	High arm	FZ10039	1
22.	M24 regular washer	FW24	2
23.	M24 self-locking nut	LN2415	2
24.	Suspension	FZ10040	1
25.	Folding pin	FZ10041	2
26.	Bolt M8x20-8.8	BM0812520	1
27.	Spring washer M8	LW08	1
28.	Suspension fuse pin	FZ10042	1
29.	Suspension fuse	FZ10043	1
30.	M22 regular washer	FW22	1
31.	Spring-type straight pin 5x40	FZ10044	1
32.	Suspension top pin	FZ10045	1
33.	Washer M12, large	LFW12	2
34.	M12 self-locking nut	LN12125	1
35.	PTO shaft hanger	FZ10046	1
36.	M20 self-locking nut	LN2015	1
37.	M20 regular washer	FW20	1
38.	Lower suspension pin	FZ10047	1
39.	Support foot	FZ10048	1

#### 7.4. Rear curtain

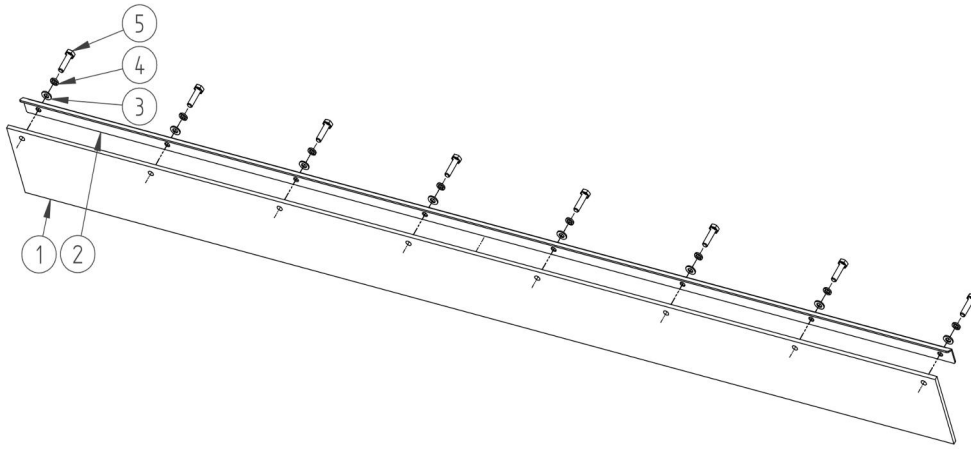

Item	Name		Index	Qty
1.	Rear rubber shield Sabre-51	Rear Sabre-51	FZ10049	1
	rubber shield Sabre-61	Sabre-61	FZ10050	1
2.	Rear curtain angle profile; Sabre-51	Rear Sabre-51	FZ10051	1
	curtains angle profile; Sabre-61	Sabre-61	FZ10052	1
3.	M8 regular washer	Sabre-51	FW08	7
		Sabre-61		8
4.	Spring washer M8	Sabre-51	LW08	7
		Sabre-61		8
5.	Bolt M8x30-8.8	Sabre-51	BM0812530	7
		Sabre-61		8

## 7.5. Running gear

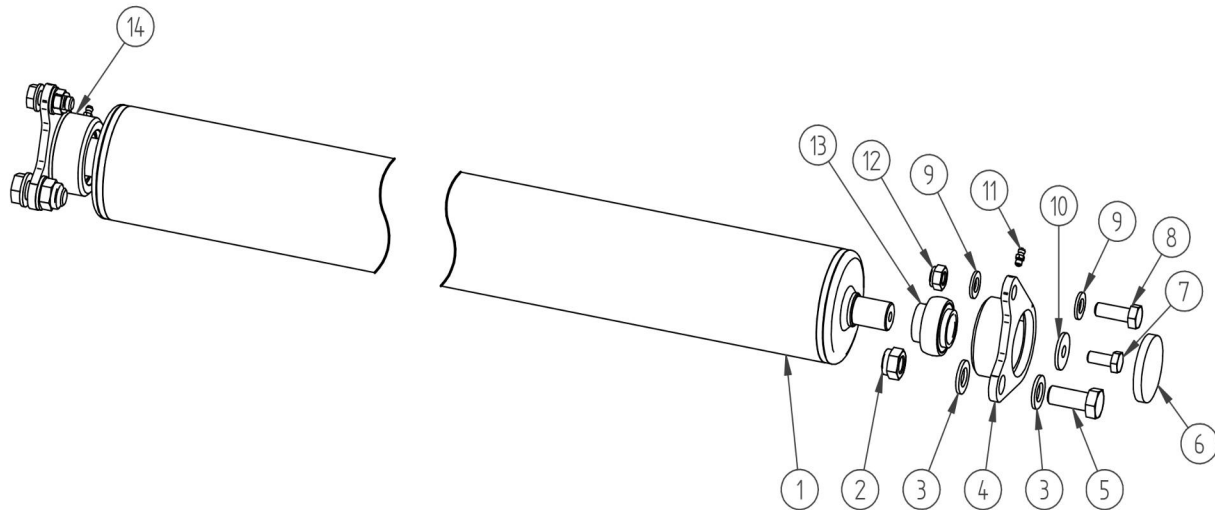

Item	Name	Index	Qty
1.	Drive shaft; Sabre-51	Sabre-51 FZ10053	1
	Drive shaft; Sabre-61	Sabre-61 FZ10054	1
2.	M16 self-locking nut	LNM1615	2
3.	M16 regular washer	FW16	4
4.	Shaft left mount	FZ10055	1
5.	Bolt M16x40-8.8	BM161540	2
6.	EC blind cap	FZ10056	2
7.	Bolt M10x25-8.8	BM1012525	1
8.	Bolt M12x35-8.8	M1212535	2
9.	M12 regular washer	FW12	4
10.	Locking washer	FZ10057	1
11.	Grease nipple M6x1	GN0610S	2
12.	M12 self-locking nut	LNM12125	2
13.	Bearing UC 205	FZ10058	2
14.	Shaft right mount	FZ10059	1

## 7.6. Work assembly

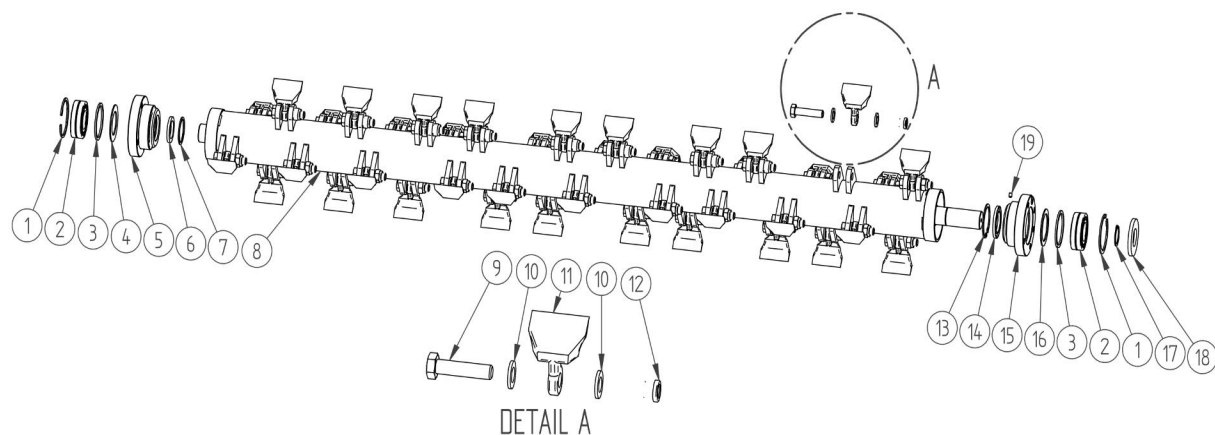

Item	Name	Index	Qty	
1.	Snap ring, straight cut W72	SRI-72	2	
2.	Bearing 22207	FZ10060	2	
3.	Bearing washer RBL	FZ10061	2	
4.	Bearing ring RBL int. d=46mm	FZ10062	1	
5.	Right housing	FZ10063	1	
6.	Seal 35x50x5	OS355005	1	
7.	Snap ring W50	SRI-50	1	
8.	Working shaft; Sabre-51	Sabre-51	FZ10064	1
	Working shaft; Sabre-61	Sabre-61	FZ10065	1
9.	Special bolt M14x60-10.9	Sabre-51	FZ10066	32
		Sabre-61		40
10.	Washer	Sabre-51	FZ10067	64
		Sabre-61		80
11.	Hammer	Sabre-51	FZ10068	32
		Sabre-61		40
12.	M14 self-locking nut	Sabre-51	LNM1415	32
		Sabre-61		40
13.	Snap ring W62	SRI-62	1	
14.	Seal 40x62x5	OS406205	1	
15.	Left housing	FZ10069	1	
16.	Bearing ring RBL int. d=54mm	FZ10070	1	
17.	Snap ring Z35	SRI-35	1	
18.	Seal 35x72x7	OS357207	1	

### 7.7. Right slider

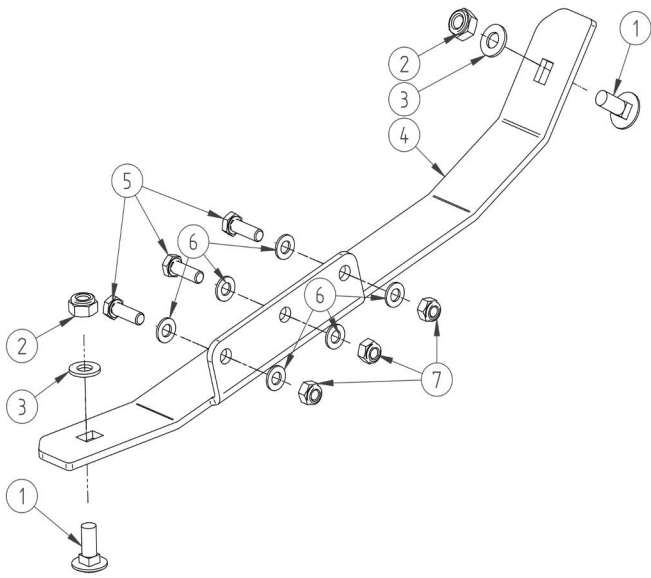

### 7.8. Left slider

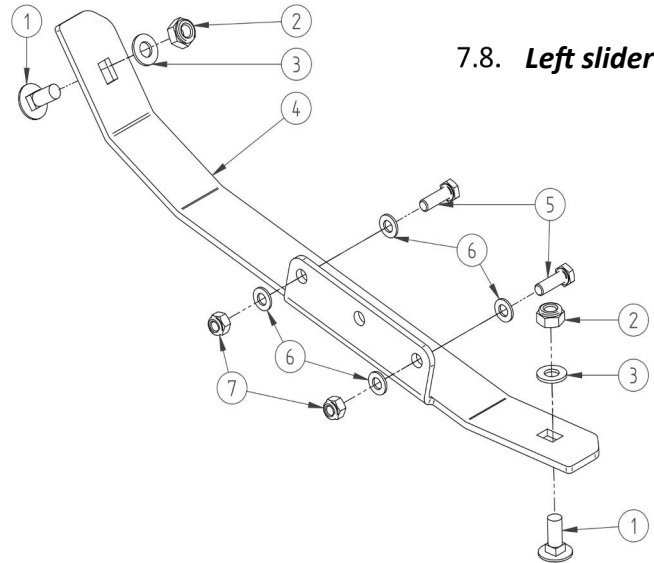

Item	Name	Index	Qty
1.	M10x25 carriage bolt	CBM101525	2
2.	M10 self-locking nut	LN1015	2
3.	M10 regular washer	FW10	2
4.	Right slider; Sabre	FZ10071	1
	Left slider; Sabre	FZ10072	1
5.	Bolt M8x25-8.8	BM0812525	2
6.	M8 regular washer	FW08	4
7.	M8 self-locking nut	LN08125	2

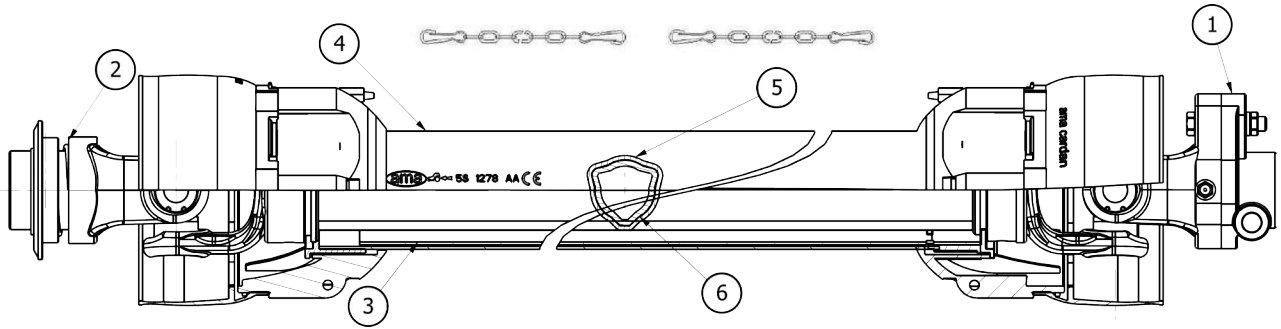

PTO Driveline

Item	Name	Index	Qty
1.	Yoke assembly (implement end) - FZ10016, PTO complete	FZ10131	1
2.	Yoke assembly (tractor end) - FZ10016, PTO complete	FZ10132	1
3.	Inner guard tube - FZ10016, PTO complete	FZ10133	1
4.	Outer guard tube - FZ10016, PTO complete	FZ10336	1
5.	Outer tube - FZ10016, PTO complete	FZ10037	1
6.	Inner tube - FZ10016, PTO complete	FZ10038	1
-	Locking collar, for PTO FZ10016	FZ10339	1
-	PTO complete 620Nm L=1500 w/shear bolt	FZ10016	1

### 7.9. Hydraulic system

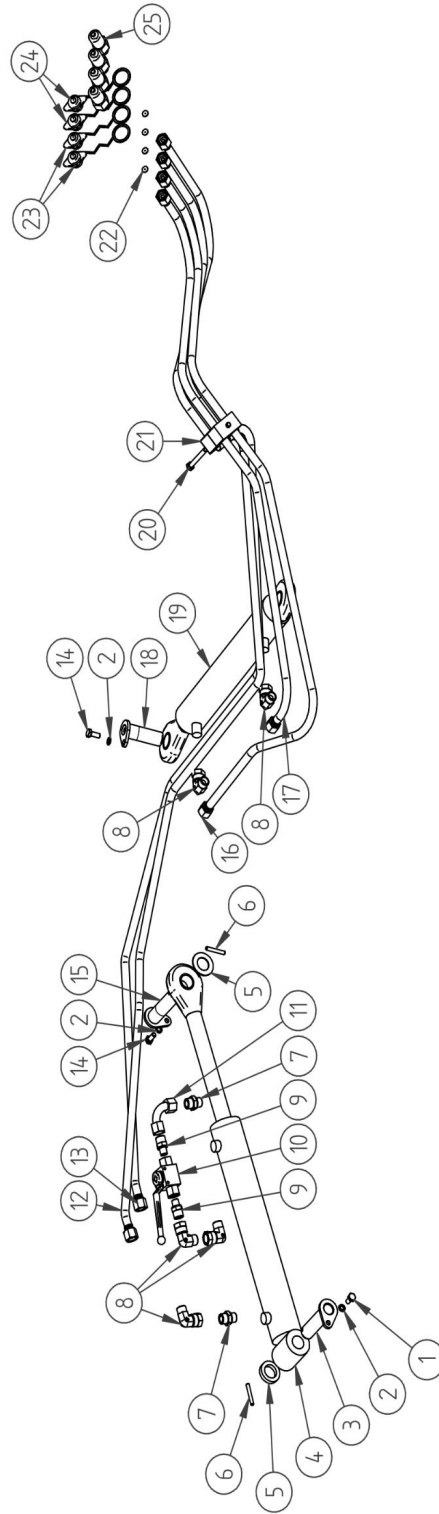

Item	Name	Index	Qty
1.	Bolt M8x16-8.8	BM0812516	1
2.	Spring washer M8	LW08	3
3.	Cylinder-body pin	FZ10073	1
4.	Body positioning cylinder	FZ10074	1
5.	Washer M25	FW25	2
6.	Spring-type straight pin 6x40	FZ10075	2
7.	Straight connector G3/8"/M18x1.5 ED/12L	FZ10076	2
8.	Elbow fitting AB	FZ10077	5
9.	Straight connector G1/4-M18x1.5	FZ10078	2
10.	Ball valve 2/2-1/4	FZ10079	1
11.	Arc fitting AA	FZ10080	1
12.	Cable 1/2/P51 L-3625	FZ10081	1
13.	Cable 1/2/P51 L-3375	FZ10082	1
14.	Bolt M8x20-8.8	BM0812520	2
15.	Cylinder-turntable pin	FZ10083	1
16.	Cable 1/2/P51 L- 2300	FZ10084	1
17.	Cable 1/2/P51 L- 2000	FZ10085	1
18.	Cylinder-arm pin	FZ10086	1
19.	Arm positioning actuator	FZ10087	1
20.	Bolt M8x60 -8.8 GALV	BM0812560	1
21.	Bracket 2x15	FZ10088	2
22.*	Choke 9.8x1	FZ10089	4
23.	Yellow dust cap	FZ10090	2
24.	Black dust cap	FZ10091	2
25.**	1/2 quick fit coupling plug	FZ10092	4

\*in some models may be located on the cylinder side

\*\*the quick fit couplers come complete with a washer(T004392)

7.10. **Belt transmission shield**

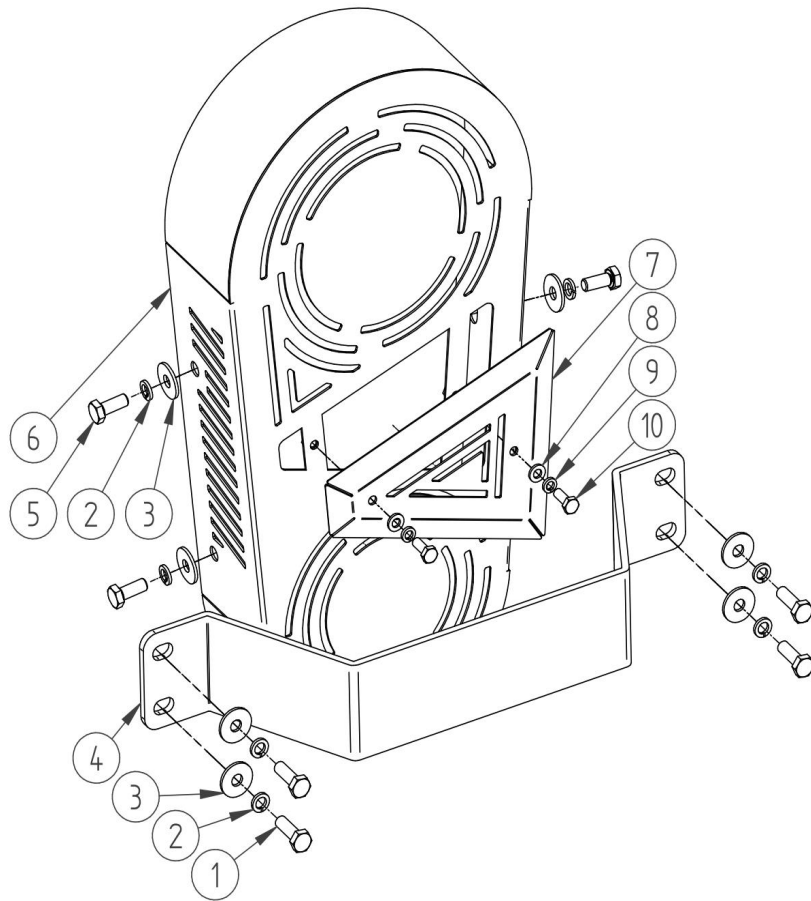

Item	Name	Index	Qty
1.	Bolt M8x25-8.8	BM0812525	4
2.	Spring washer M8	LW08	7
3.	Extensional washer M8	LFW08	7
4.	Side slide	FZ10093	1
5.	Bolt M8x20-8.8	BM0812520	3
6.	Belt shield; Sabre	FZ10094	1
7.	Shield sight glass	FZ10095	1
8.	M6 regular washer	FW06	2
9.	Spring washer M6	LW06	2
10.	Bolt M6x16-8.8	BM061016	2

7.11. **Front curtain**

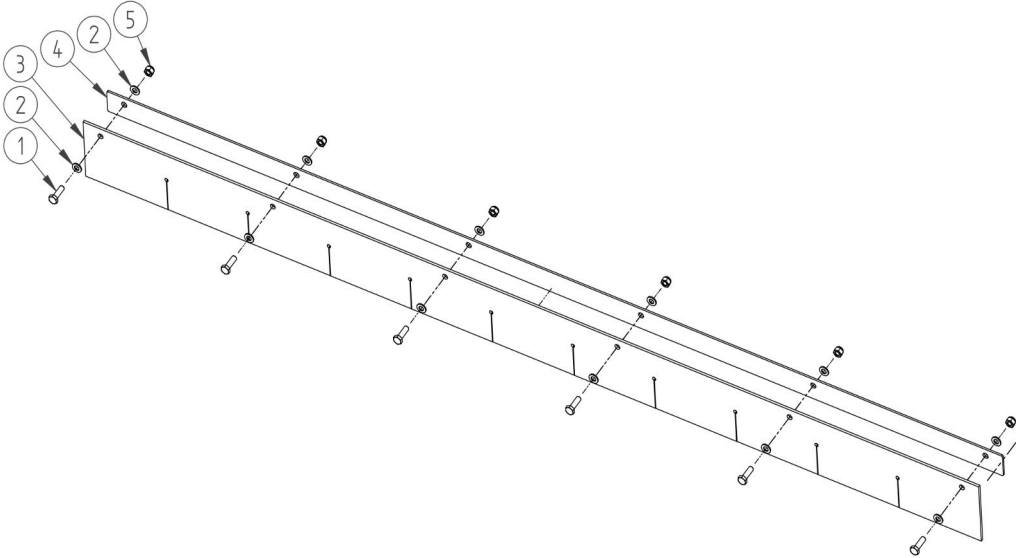

Item	Name		Index	Qty
1.	Bolt M8x25-8.8	Sabre-51	BM0812525	5
		Sabre-61		6
2.	M8 regular washer	Sabre-51	FW08	10
		Sabre-61		12
3.	Front curtain rubber shield; Sabre-51	Sabre-51	FZ10096	1
	Front curtain rubber shield; Sabre-61	Sabre-61	FZ10097	1
4.	Front curtain panel; Sabre-51	Sabre-51	FZ10098	1
	Front curtain panel; Sabre-61	Sabre-61	FZ10099	1
5.	M8 self-locking nut	Sabre-51	LNM08125	5
		Sabre-61		6

7.12. *Other*

7.12.1. Turntable buffer

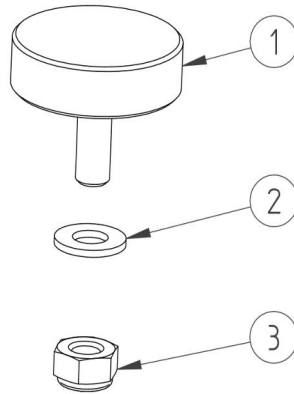

Item	Name	Index	Qty
1.	Bumper D5015M10X28	FZ10100	1
2.	M10 regular washer	FW10	1
3.	M10 self-locking nut	LN10125	1

7.12.2. Lubricator cover assembly

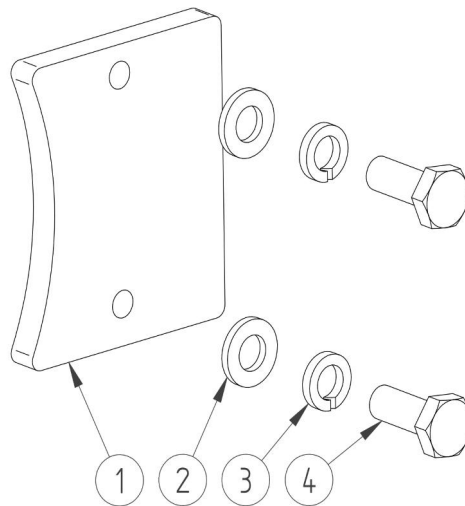

Item	Name	Index	Qty
1.	Lubricator cover	FZ10101	1
2.	M6 regular washer	FW06	2
3.	Spring washer M6	LW06	2
4.	Bolt M6x16-8.8	BM061016	2

## **8. LIMITED WARRANTY**

Belco Resources Equipment warrants to the original purchaser of any new piece of machinery from Belco Resources Equipment, purchased from an authorized Belco Resources Equipment dealer, that the equipment be free from defects in material and workmanship for a period of one (1) year for non-commercial, state, and municipalities' use, ninety (90) days for commercial use from date of retail sale. Warranty for rental purposes is thirty (30) days. The obligation of Belco Resources Equipment to the purchaser under this warranty is limited to the repair or replacement of defective parts.

**Replacement or repair parts installed in the equipment covered by this limited warranty are warranted for ninety (90) days from the date of purchase of such part or to the expiration of the applicable new equipment warranty period, whichever occurs later. Warranted parts shall be provided at no cost to the user at an authorized Belco Resources Equipment dealer during regular working hours. Belco Resources Equipment reserves the right to inspect any equipment or parts, which are claimed to have been defective in material or workmanship.**

**This limited warranty does not apply to and excludes wear items such as shear pins, tires, tubes knives, blades or other wear items. Oil or grease is not covered by this warranty.**

**All obligations of Belco Resources Equipment under this limited warranty shall be terminated if:**

**Proper service is not performed on the machine.**

**The machine is modified or altered in any way.**

**The machine is being used or has been used for purposes other than those for which the machine was intended.**

## **DISCLAIMER OF IMPLIED WARRANTIES & CONSEQUENTIAL DAMAGES**

**Belco Resources Equipment obligation under this limited warranty, to the extent allowed by law, is in lieu of all warranties, implied or expressed, including implied warranties of merchantability and fitness for a particular purpose and any liability for incidental and consequential damages with respect to the sale or use of the items warranted. Such incidental and consequential damages shall include but not be limited to: transportation charges other than normal freight charges; cost of installation other than cost approved by Belco Resources Equipment; duty; taxes; charges for normal service or adjustment; loss of crops or any other loss of income; rental of substitute equipment, expenses due to loss, damage, detention or delay in the delivery.**

## **REGISTRATION**

**The online Warranty Registration must be completed in order to qualify for coverage on this Limited Warranty. Visit [br-equipment.com](http://br-equipment.com), click on "Warranty Registration" and completely fill out the form to register the new piece of equipment.**

**Page left blank intentionally**

**Page left blank intentionally**

**Page left blank intentionally**



Belco Resources Equipment  
401 Jeffrey's Road  
Rocky Mount, NC 27804  
Tel:(252) 822-7140  
Email:[sales@br-equipment.com](mailto:sales@br-equipment.com)  
[www.br-equipment.com](http://www.br-equipment.com)