

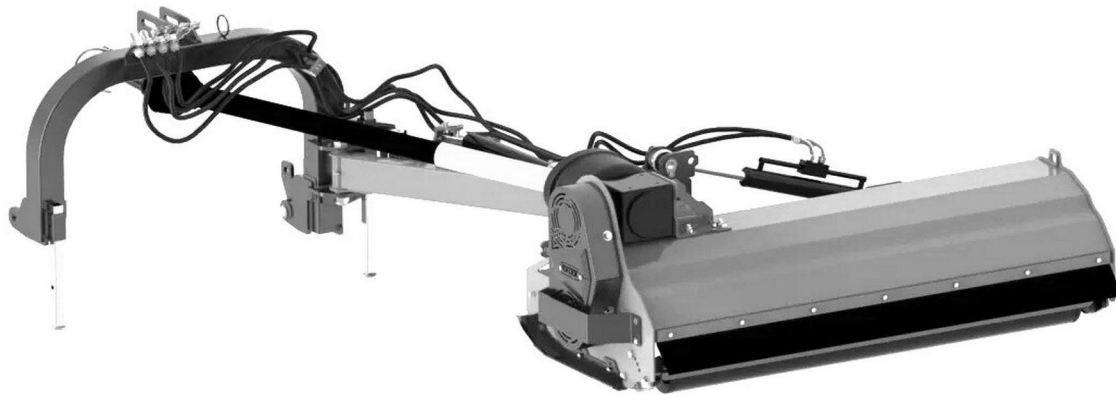

## Operator's & Parts Manual



**FLAIL MOWER**

**Katana**



## **CAUTION!**

Before using the machine, please read thoroughly this Instruction Manual and observe the safety instructions contained herein.

### **The instructions manual is a part of the basic equipment of the machine!**

Keep the manual in a safe place, where it is available to the user and service technician through the entire life cycle of the machine.

In the event of its loss or damage, the user must acquire a new copy from the machine dealer or manufacturer.

In the event the machine is sold or made available to another user, the Instructions Manual must be attached with the declaration of conformity for the machine.

The manufacturer reserves its copyrights to the Instructions Manual.

Copying, processing of the Instructions Manual and its parts without the manufacturer's permission is strictly prohibited

Belco guarantees efficient operation of the machine, provided it is used in accordance with the technical and operating conditions specified in this INSTRUCTIONS MANUAL.

All faults revealed during the warranty period will be repaired by the Warranty Repairs Service. The expiration date of the warranty period is specified in the WARRANTY CARD.

The warranty does not cover parts and components of the machine subjected to wear and tear under normal operating conditions regardless of the warranty period, i.e.: bearings, cutting blades/hammers, aprons/protective covers, hydraulic hoses, etc.

The Warranty Service covers only instances such as mechanical damage not caused by a fault of the user, production defects, etc.

If any damage results from:

- mechanical damage caused by a fault of the user or a traffic accident,
- improper use, adjustment and maintenance, use of the machine for a purpose other than intended,
- operating a damaged machine,
- repairs conducted by unauthorized persons or improper repairs,
- unauthorized changes to the machine structure,

the user may invalidate its rights to the In-Warranty Services.

The user is obliged to immediately report all identified faults and have them repaired, regardless of whether the damage is covered by the warranty or not. Special warranty terms and conditions are laid out in the WARRANTY CARD attached to the newly purchased machine.

## Table of Contents.

1.	Machine Identification .....	6
2.	Introduction .....	7
2.1.	Read the instructions manual .....	7
2.2.	Intended use of the machine .....	7
2.3.	Warranty .....	8
3.	Occupational health and safety technique .....	8
3.1.	Basic safety principles .....	8
3.2.	Safety signs on the machine.....	10
3.3.	Hazards in operating the flail mower .....	12
3.4.	Transport .....	13
3.5.	Working elements of the machine .....	13
3.6.	Machine suspended on a three-point hitching system .....	13
3.7.	Machine disconnected from the tractor .....	13
3.8.	Work with jointed-telescopic shaft .....	13
3.9.	Operation .....	14
3.10.	Technical specification .....	15
3.11.	Design and operation .....	17
4.	Operation .....	18
4.1.	Working position. ....	20
4.2.	Transport position. ....	23
4.3.	Mowing height adjustment using the running shaft .....	27
4.4.	Cylinder extension speed adjustment. ....	27
4.5.	Operation .....	28
5.	Recommended machine operation .....	28
5.1.	Oil change points .....	28
5.2.	Lubrication points .....	29
5.3.	Tensioning of the V-belts .....	30
5.4.	Changing cutting tools .....	31
6.	Technical inspections, storage, disposal .....	33
6.1.	Storage .....	34
6.2.	Dismantling and disposal .....	34
6.3.	Stability .....	34
7.	Spare parts catalog .....	36

- 7.1. General design ..... 37
- 7.2. Drive system ..... 38
  - 7.2.1. Belt tensioner ..... 40
- 7.3. Hitch suspension system ..... 41
- 7.4. Rear curtain ..... 43
- 7.5. Running gear ..... 44
- 7.6. Work assembly ..... 45
- 7.7. Right slider ..... 46
- 7.8. Left slider ..... 47
- 7.9. Hydraulic system ..... 48
- 7.10. Belt transmission shield ..... 49
- 7.11. Front curtain..... 51
- 7.12. Other ..... 52
  - 7.12.1. Turntable buffer ..... 52
  - 7.12.2. Knife ..... 52
  - 7.12.3. Bumper set ..... 53
- 8. Warranty ..... 54

## 1. Machine identification

All the information required for identification is provided on a nameplate attached to the body of the machine. It contains information such as: the name and address of the manufacturer, the year of manufacture, the serial number, the weight of the machine.



Figure 1. Nameplate

If in doubt, any information about the machine and explanations of the instruction manual should be provided by the dealer or distributor.

### **Distributor Address**

#### **Belco Resources Equipment**

401 Jeffrey's Road

Rocky Mount, NC27804

Tel.: (252) 822-7140

e-mail: [sales@br-equipment.com](mailto:sales@br-equipment.com),

website: [www.br-equipment.com](http://www.br-equipment.com)

## 2. Introduction



### CAUTION!

This symbol warns of a hazard. The warning symbol indicates an important hazard information given in the Instructions Manual. Please read the notice, follow the instructions it specifies and take special caution.

### 2.1. *Read the instructions manual*



### CAUTION!

Read the instructions manual  
before use

**The Instructions Manual belongs is a part of the equipment of the machine. Make sure that you have become thoroughly familiar with its content before starting any works with the machine.**

This manual provides the user with information regarding operation, use and maintenance of the machine. It contains performance characteristics, requirements for safe and correct operation of the machine, allowing it to be used in the best possible way while retaining the maximum service life and reliability. Careful reading of the instructions manual will help to avoid accidents and enable long and trouble-free operation.

### 2.2. *Intended use of the machine*

The machine is designed for side of the road and standard agricultural use, i.e. for mowing and shredding of short-stem plants (bushes, plant stems, etc.).

Using the mower for other purposes will be considered as unintended use, which excludes the manufacturer's liability for the resulting damage.

- The machine can be operated only by persons who have been properly trained and made themselves familiar with the instructions manual and hold the required license to drive the vehicle coupled with the machine.
- The mower should be used in accordance with its intended use and should be maintained and repaired correctly.
- Observe the safety regulations provided in this manual, general occupational health and safety rules and traffic regulations.
- Observe the occupational health and safety rules while operating and maintaining the machine.
- Any unauthorized modifications made to the machine exclude the manufacturer's liability for any resulting damage.

### 2.3. **Warranty**

The warranty terms are provided in the warranty card. The operator of the machine is obliged to get thoroughly familiar with this instructions manual. Failure to adhere to the correct operation rules leads to decreased efficiency of the mower, its breakdowns and loss of the warranty rights. The warranty rights will become invalid particularly if:

1. Mechanical damage caused by operation not in accordance with the instructions manual is found.
2. Repairs are carried out by workshops other than the seller's service station, the manufacturer's service station or service stations recommended by them.
3. Spare parts other than the genuine spare parts of the manufacturer have been used.
4. Unauthorized modifications of the design of the mower are prohibited.

## 3. Occupational health and safety technique



Most accidents which happen at work, during operation or transport result from failure to observe the basic safety principles. Therefore, it is important that every person in contact with the machine observes the basic safety rules referred to below in the strictest manner possible:

### 3.1. **Basic safety principles**

1. In addition to the recommendations contained in this manual, also observe the general occupational health and safety rules!
2. Follow the indications of warning inscriptions and symbols provided on the machine. This is for your safety!
3. Use of the machine without the required safety shields is prohibited; replace the damaged shields using genuine spare parts.
4. Before starting work using the mower, wait until the tractor's PTO reaches its rated speed. Do not exceed 540 rpm.
5. Any work on the machine while moving parts are rotating is prohibited, it is essential to wait until said parts have stopped. Never wear clothing which might become entangled in/by the rotating elements.
6. Never leave the mower running and unattended.
7. Before starting the mower or while operating it, make sure that there are no persons or animals within the hazard zone. **Operation of the mower with bystanders present within a distance smaller than 165 feet away is prohibited!**
8. It is forbidden to climb up the machine.
9. Fields, meadows and roadsides should be cleared of stones and hard objects – larger stones need to be removed.
10. Do not operate the mower while driving in reverse.
11. It is forbidden to step between the tractor and the machine before it has been secured against rolling away. This should be done by applying the parking brake on the tractor or by putting chocks under the running wheels.
12. The hydraulic lift lever of the tractor should be controlled only from the driver's seat position.

13. It is not permitted to operate the lifting and lowering lever from outside the vehicle.
14. It is forbidden to lift the machine on the hydraulic lift of the tractor with the drive turned on and the working shaft rotating.
15. Take special care when working on slopes and hillsides.
16. Do not use sagging, unbuttoned pieces of clothing during work, fitting, adjustments, dismantling. Keep such clothing elements away from components that can catch them.

3.2. *Safety signs on the machine*

 <p>Prior to using the machine, read the User Manual</p>	 <p>Switch off the engine and remove the key before carrying out maintenance or repair work</p>	 <p>Keep a safe distance from the machine. Do not allow bystanders to be within less than 165ft away</p>
 <p>Warning, belt transmission. Use extreme caution. Drawing-in of hand and arm.</p>	 <p>Warning, possibility of being drawn-in by the machine</p>	 <p>Keep a safe distance from the machine. Crushing of toes or foot – Force applied from above</p>
 <p>Do not ride on platforms or ladders</p>	 <p>Do not stand near the lift strands when controlling the lift</p>	 <p>Do not open or remove safety guards when the engine is running</p>

**16 MPa**

Warning message about pressure in the hydraulic system.



Keep clear of pressurised liquid leaks

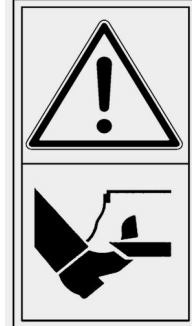

Caution - Mowing blades. Keep clear of the mower in operation



Mower handles for use during transport



Wear a protective suit



Wear safety goggles



Use hearing protectors



Wear protective gloves



Do not exceed the maximum speed

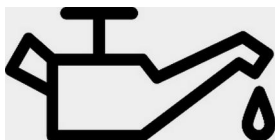

Oil change point



Lubrication point



Transport lock

### 3.3. Hazards in operating the flail mower

No.	Risk	Hazard source (cause)	Risk preventive measures
1	Overloading the locomotor system (physical load)	Working in a standing position, inclined-forced position, walking, moving objects	Read and understand the Instructions Manual; do workplace training in carrying weights standards for the manual handling, correct methods of lifting and carrying loads, getting other persons' help, and the use of handling devices such as jacks and winches.
2	Fall on the same level (tripping, slipping, etc.)	Uneven terrain, messy environment – items lying and standing around, cables lying on communication routes, slippery surfaces	Suitable working footwear, levelled terrain, paying attention, maintaining order, reading the Instructions Manual
3	Hitting protruding parts of the machine	The machine and its surroundings	Proper positioning of the machine, safe space to move around, proper work organisation, paying attention, knowledge of the instructions manual
4	Struck by moving objects	Crushed plants, incidental part of the turf, stones thrown out by the machine	Maintaining caution, marking the danger zone, prohibition of walking in the immediate surrounding of the working machine, prohibition of staying under a suspended load – suspended machine, use of personal protective equipment (helmet, safety glasses), reading the instructions manual
5	Sharp, dangerous edges	Protruding parts of the machine structure, use of hand tools	Personal protective equipment – safety gloves, buttoned up work clothes, exercising special attention
6	Belt transmission systems	Fast moving transmission pulleys and belts, rotating jointed telescopic shaft, no covers on the movable parts	Prohibition of moving, approaching and making adjustments on the running machine, exercising caution, using shields of moving parts, reading the instructions manual
7	Oil-filled mechanical transmissions, hydraulic transmission systems	Fluids, hydraulic and lubricating oils, greases, temperature, leaks, slipping, burns, injections, sensitisation, poisoning	Extreme caution, use of personal protective equipment - safety shoes, gloves and goggles, safe positioning of the machine. Familiarisation with the user manual. Familiarisation with the material safety data sheets for oils and lubricants used in the operation of the machine.
8	Weight of the suspended stationary machine	Improper mounting or coupling, wrong position of the machine, improper operation, leaving the suspended machine on a tractor	Exercising special attention, use of personal protective equipment - safety footwear, safety gloves, secure position of the machine, help of others, use of lifting jacks and hoists, reading the Instructions Manual
9	Micro climate - variable weather conditions	Work carried out in different weather conditions	Suitable working clothes, drinks, sun screen creams, proper rest, knowledge of the instructions manual
10	Noise	Excessive rotational speed of the machine, damaged, loose, vibrating parts	Work only with the machine in good mechanical condition, regular inspections, correct rotation speed, knowledge of the instructions manual
11	Thermal hazards	Contact with heat source radiation. Engine cooling systems, engine exhaust system. Temperature of the hydraulic system. Fire caused by sparks ejected upon collision with stones and other items encountered along the machine's path of operation	Use of personal protective equipment, familiarisation with the instructions manual, special care. Temperature control of operating systems of the machine and the vehicle. Use of fire protection measures - essential vehicle/carrier equipment.

### 3.4. **Transport**

- Before the mower suspended on the tractor is set into the transport position, make sure that PTO is off and all rotating elements are at rest.
- Take special care while driving on public roads with the machine attached and follow the mandatory regulations of the highway code. In addition, a portable light-warning device and a warning triangle distinguishing slow-moving vehicles should be affixed during transport.
- Adjust your travel speed on the roads to current road conditions and according to common sense.
- Be aware that the machine extends beyond the outline of the tractor while traversing bends.

### 3.5. **Working elements of the machine**

- Before using the mower, pay attention to the condition of attachment of the cutting elements.
- Worn and damaged cutting elements and their attachments must be replaced immediately with original spare parts.

### 3.6. **Machine suspended on a three-point hitching system**

- Before suspending on or removing the mower from the three-point hitching system of the tractor, set the hydraulic lift lever in a position preventing unintended lifting or lowering of the machine.
- The categories of the tractor hitching system and that of the machine must be compatible.
- While the machine is in the transport position, always pay attention to the side stability of the connection between the tractor and the mower.
- While the machine is transported in the raised position, the hydraulic lift control lever must always be secured against lowering.

### 3.7. **Machine disconnected from the tractor**

Park the machine on a stable and even substrate, in a place protected from the weather and from outsiders.

### 3.8. **Work with jointed-telescopic shaft**

- Use only jointed-telescopic shafts supplied by the machine manufacturer or with similar characteristics.
- All installed shields of the jointed-telescopic shaft must be in good condition. Immediately replace the shaft shields when damaged.
- Install and remove the jointed-telescopic shaft only when the power transmission shaft is off, the motor is off and the key is removed from the ignition switch!
- Always make sure that the jointed-telescopic shaft halves overlap in the working position and the transport position as required by the regulations!
- Secure the shaft shield with a chain to prevent it from rotating with the shaft!
- Before turning on the power transmission shaft, make sure that the direction of rotations and the rotational speed of the power transmission shaft are compatible with the power take-off shaft rotations.

- Before turning on the power transmission shaft, make sure that no one is present nearby, within hazardous distance from the machine.
- Turn off the jointed-telescopic shaft when its operation is not necessary.
- After turning off the power transmission shaft, wait for the inertial rotation of the rotating weights to stop before anyone enters the hazardous zone.
- After disconnecting the jointed-telescopic shaft, slide on the shields again and put the shaft away in the designated location.
- If damage has occurred, it must be repaired immediately or the shaft replaced with a new one.

### 3.9. **Operation**

Carry out all repairs, maintenance and adjustments only with the drive disconnected, the engine switched off and the ignition key removed. Pay special attention to the hazards present while the machine is being switched from the working position to the transport position.



Use protective clothing and gloves while carrying out maintenance works - especially while replacing cutting elements!



It is forbidden to operate the machine on edges of streets, roads, public squares (parks, schools etc.) or stony terrain to avoid the hazard related to the stones and other objects being thrown.



All labels applied onto the machine must be legible. If any of the labels becomes damaged, the owner / user is obliged to replace it with a new one.

### 3.10. Technical specification

TYPE		Katana-65
Power requirement		min 40 HP, max 70 HP
3-point hitch category		I/II
Weight		370 kg [816 lbs.]
Number of flails/knives		26/52
Working speed		3-5 km/h [2-3 mph]
Transport speed		up to 20 km/h [12 mph]
Power take-off speed of the vehicle		540 rpm
Operating width[A]		1650mm [65"]
Dimension[B]		585mm [23"]
Dimension[C]		810mm [32"]
Dimension[D]		1910mm [75"]
Dimension[E]		1485mm [58"]
Dimension[F]		90°
Dimension[G]		50°
Dimension[H]		850mm [33"]
The level of noise emitted by the machine	$L_{pA}$	$89,3 \frac{+2,1}{+0}$ dB
	$L_{Amax}$	$97,0 \frac{+2,6}{+0}$ dB
	$L_{Cpeak}$	$125,8 \frac{+2,6}{+0}$ dB

$L_{pA}$  – The level of exposure to noise related to the 8-hour daily working time.

$L_{Amax}$  – Maximum sound measurement value.

$L_{Cmax}$  – Peak sound level.

**\*The weight of the tractor coupled to the machine is important. In connection with this parameter follow Chapter 6.3 Stability.**

Figure 1. Basic dimensions

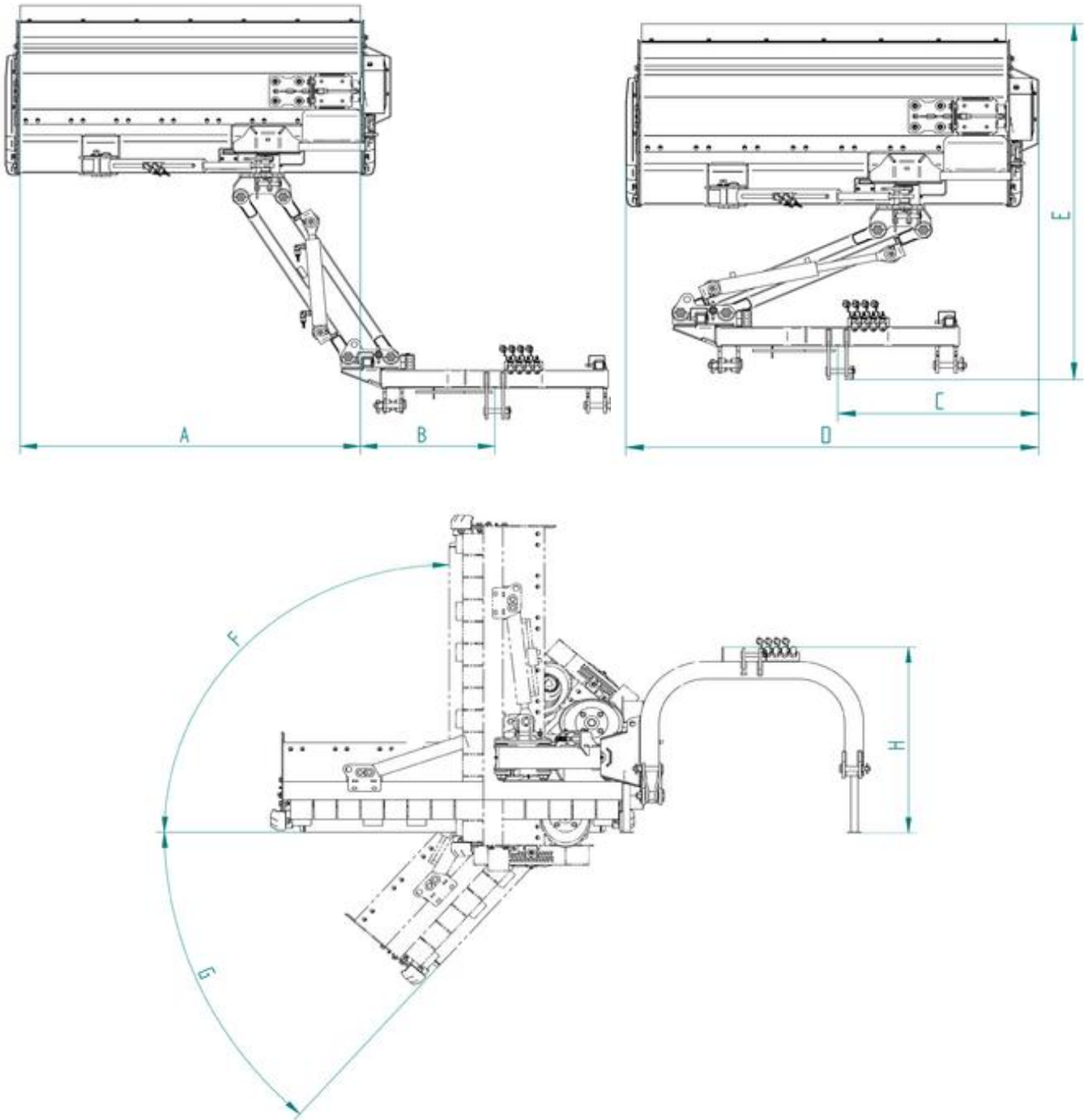

### 3.11. *Design and operation*

The Katana flail mower is a machine that allows work to be carried out at the rear of the tractor. A suspension system (3) allows the machine to be connected to the tractor. The jointed-telescopic shaft is responsible for transmitting the drive to the drive system (2). The main components of the drive system are the angular gearbox and belt transmission, which transmits the drive to the working shaft (6) embedded in the body (1). The entire machine travels on the ground on a jockey shaft (5), which is also referred to in the manual as a running shaft. In addition, sliders (7,8) and a bumper (12) have been incorporated for better protection of the machine during operation and more comfortable use. A front curtain (11) and rear curtain (4) protect against ejected objects during mowing. A hydraulic system (9) is responsible for tilting the machine on inclines and in hard-to-reach places.

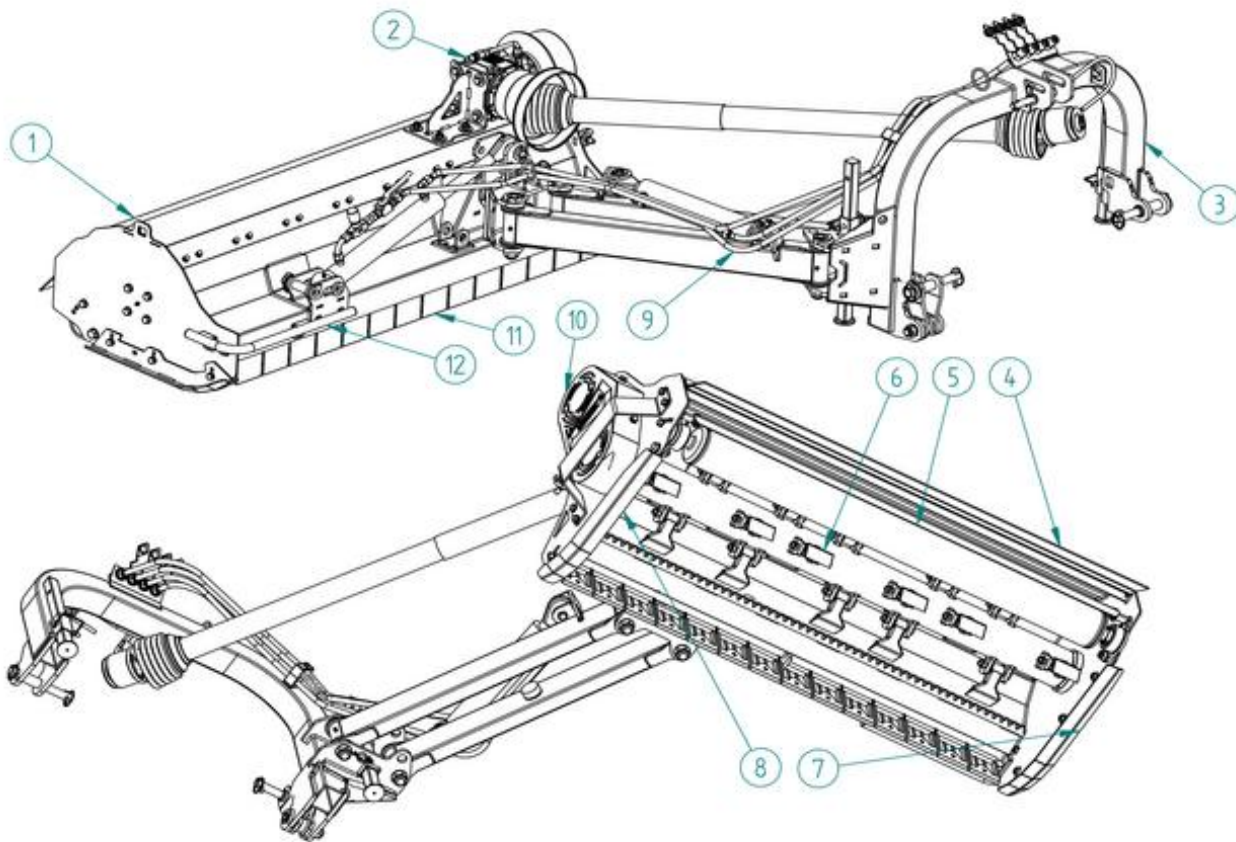

**Figure 2.** General design

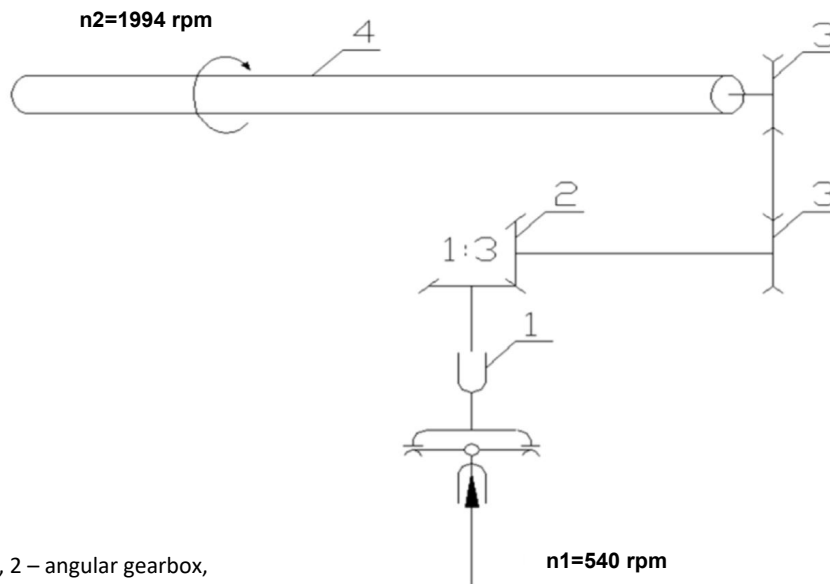

1 - jointed-telescopic shaft, 2 – angular gearbox,  
3 – belt transmission, 4 – working shaft.

Figure 3. Drive diagram

## 4. Operation

The manufacturer guarantees that the machine is fully operational and has been checked in accordance with quality control procedures and approved for use. However, this does not relieve the user from the obligation to inspect the machine after its delivery.

**Before every time the mower is used, its mechanical condition needs to be checked, and especially the condition of cutting unit, drive transmission system, hydraulic system and guarding shields.**



**The machine can be started once it is supported on the ground. It is prohibited to engage the drive when the machine is raised above the working surface and not resting on the ground. It is prohibited to lift a running machine on a hoist. Disconnect the drive and wait until rotation stops before lifting the machine.**

### I. Coupling the suspension system of the vehicle and the machine.

- The machine is mounted on a three-point hitch suspension system of the tractor. Before coupling, position the lower attachment as shown in the drawing below. The component shown tilts the machine when it encounters an obstacle.

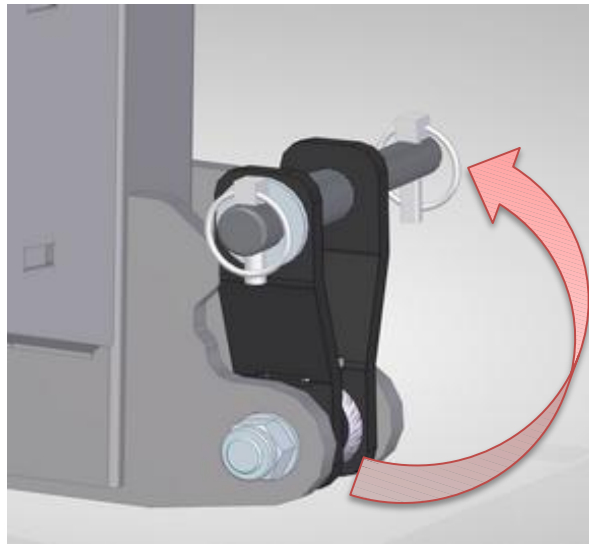

**Figure 4.** Positioning of the lower attachment during coupling.

- During operation, a correctly adjusted central link is important. This is indicated by the sliders, which should be parallel to the ground.
- Each time the mower is mounted on the vehicle, check the connecting elements, i.e. pins and plugs, for wear. In case of wearing out replace them with new ones.



**Take special care that no-one is in the area between the machines when coupling the machine and the tractor.**

### II. Connecting the drive shaft of the machine.

- Once the machine is mounted on the three-point linkage, the jointed-telescopic shaft must be fitted.
- Pay particular attention to the correct installation of the shaft and its securing. Follow the instructions supplied with the shaft. Carry out all operations such as correct cutting and lubrication in accordance with the instructions.

### III. Connecting the power hydraulic system.

- The machine is equipped with two double-acting cylinders.
- When connecting the hydraulic lines, make sure that the hydraulic system is not pressurized
- The hydraulic lines are marked with two colors Each color corresponds to one cylinder.
- Ensure that the cylinders are controlled correctly before proceeding.
- Each time before work, pay attention to the condition of the cables and connections. Replace all defective system components with new ones. If leaks occur, the condition of the connections should be checked.
- The hydraulic system is pressurized and should therefore be handled with extreme care.

#### 4.1. ***Working position.***

Before starting work, the machine must be properly prepared and set up:

- The central link (A) should be set in the middle position of the longitudinal hole, the machine should rest on the running shaft, while the sliders (B) should be set relatively parallel to the ground. Once adjusted, raise both support feet (C,D).

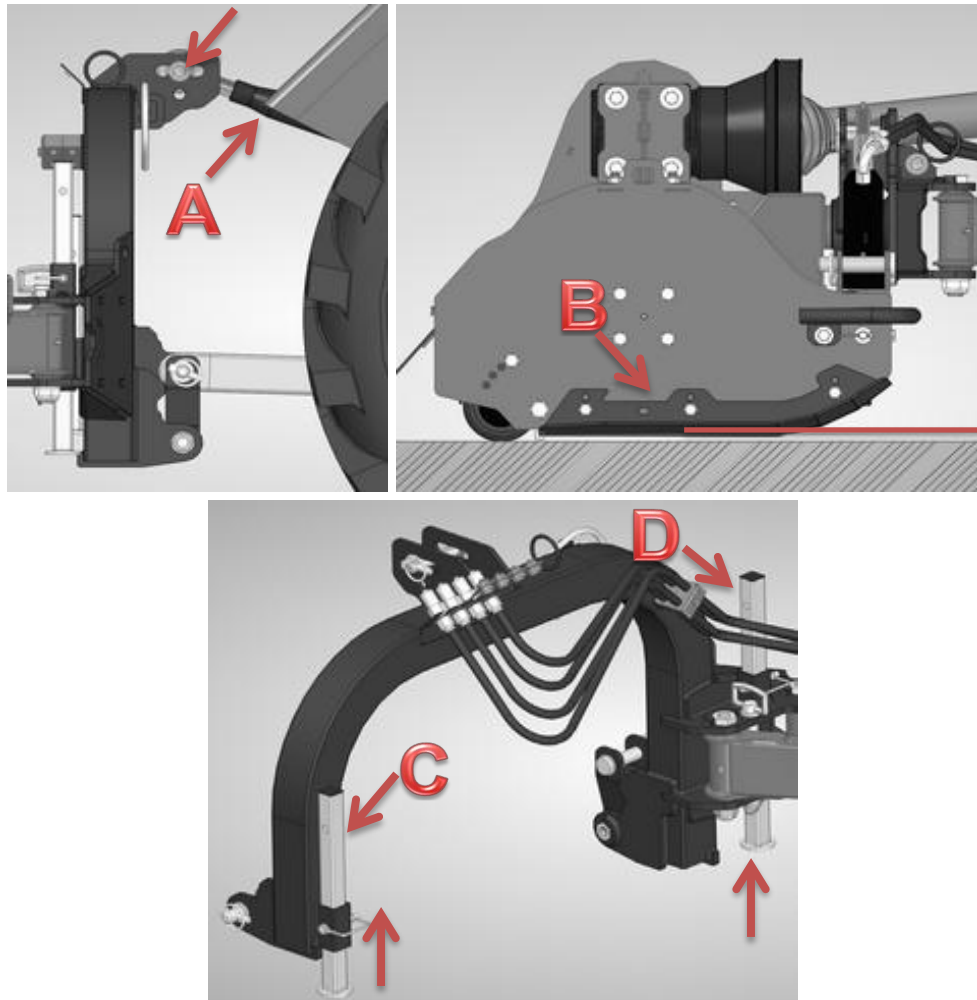

Figure 5. Working position

- The next step is to reposition the transport locks at the locations indicated in Figure 6.



**Removal of the transport locks is necessary to allow free movement of the cylinder and arms.**

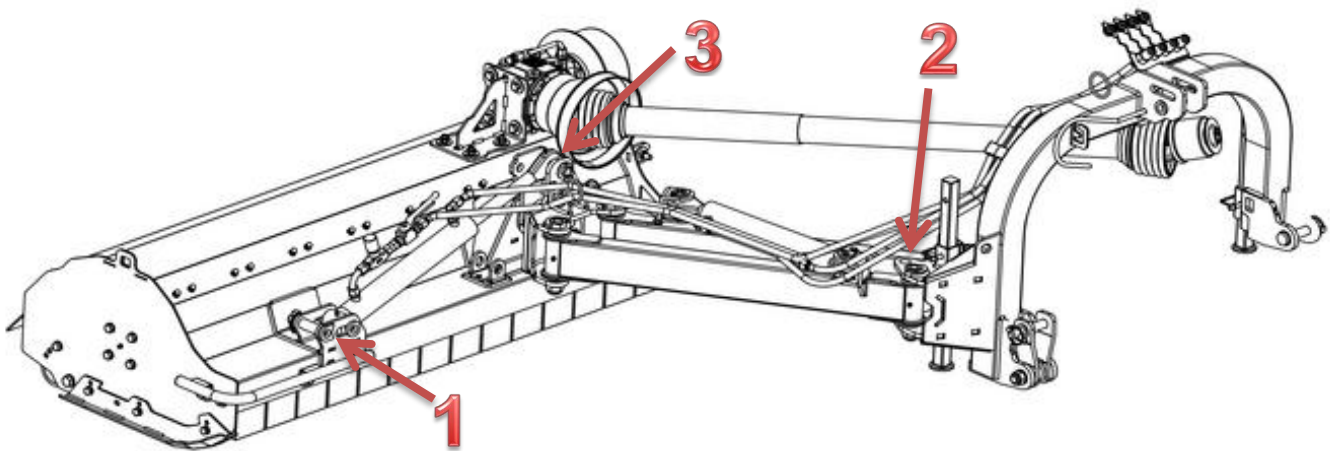
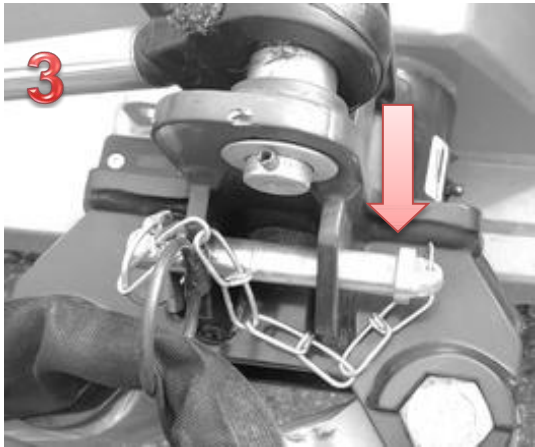
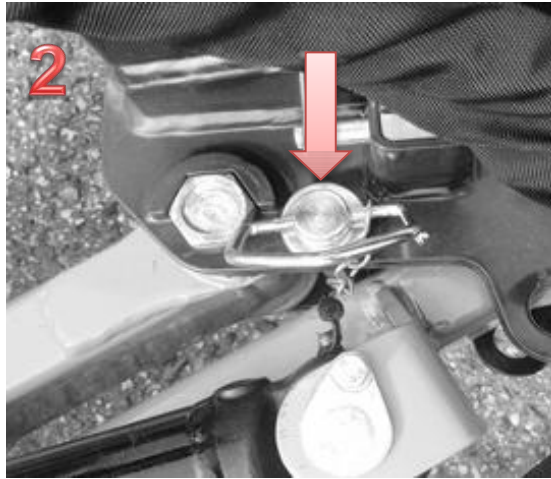
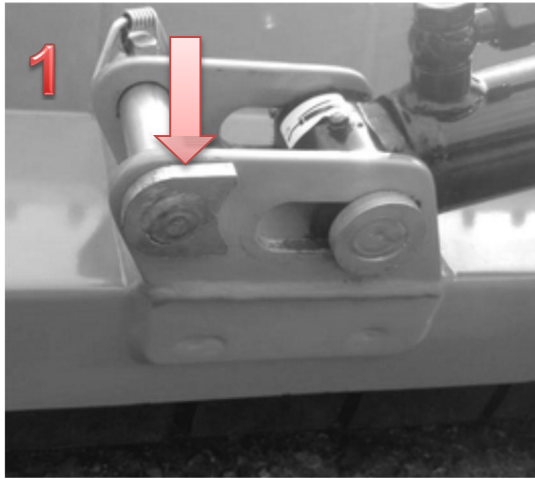

Figure 6. Position of transport locks during operation

- It is vital that the PTO shaft length is correctly selected. If the shaft is too long, it should be shortened according to the instructions supplied with it.

#### 4.2. *Transport position.*

Before transporting the machine, the following actions must be performed:

- If the machine has been used, it is necessary to wait until the rotation of the working shaft due to its inertia has stopped.
- Place the central coupling pin (A) in the transport hole shown in Figure 7. Position the arms (B) so that they rest against each other. To do this, the arm cylinder (C) must be fully extended.

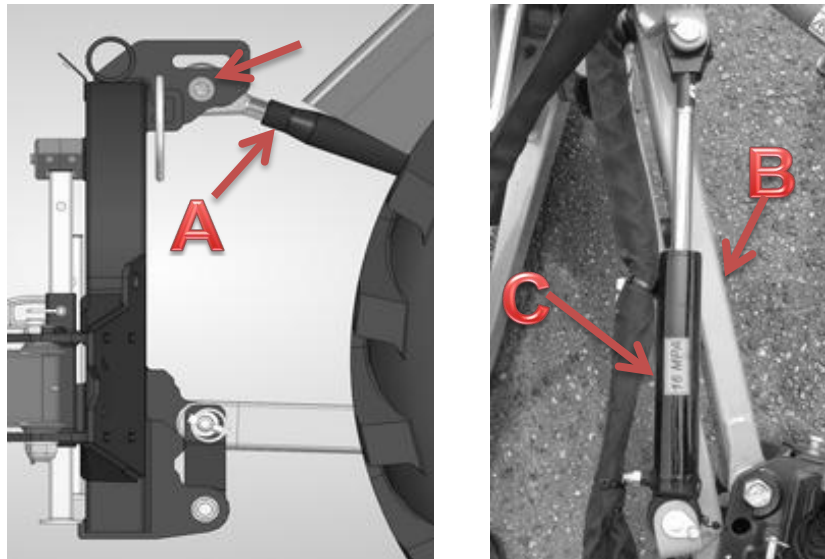

**Figure 7. Adjustment of arms and suspension for transport**

- The next step is to secure the arms and cylinders with transport pins by repositioning them in the locations indicated in Figure 8. Location similar to Figure 6.

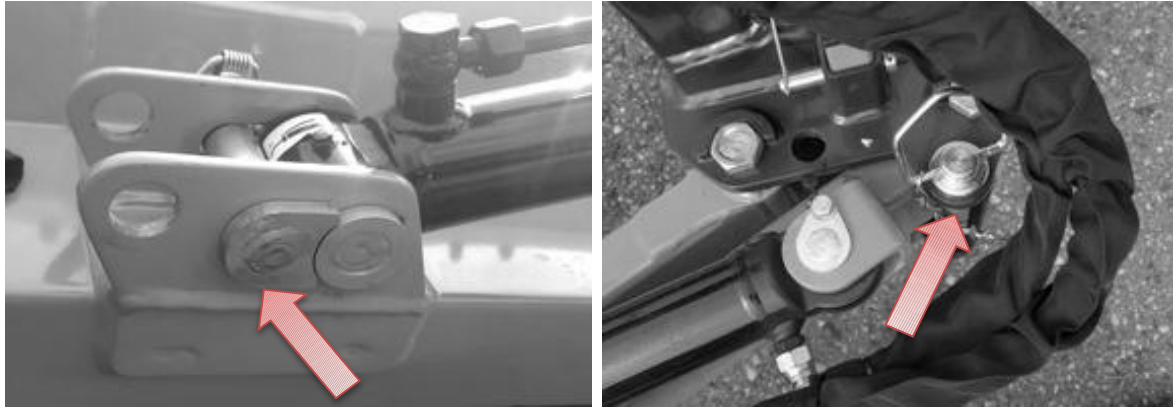

**Figure 8. Transport pins**

- In order to transport the machine in the vertical position shown in Figure 9, the machine must be lifted and, by folding the cylinder on the body, placed in this position. The machine in this position must be at

a minimum of 8.00" from the ground. It is also necessary to reposition the transport lock pin to the location marked with the arrow in Figure 9.

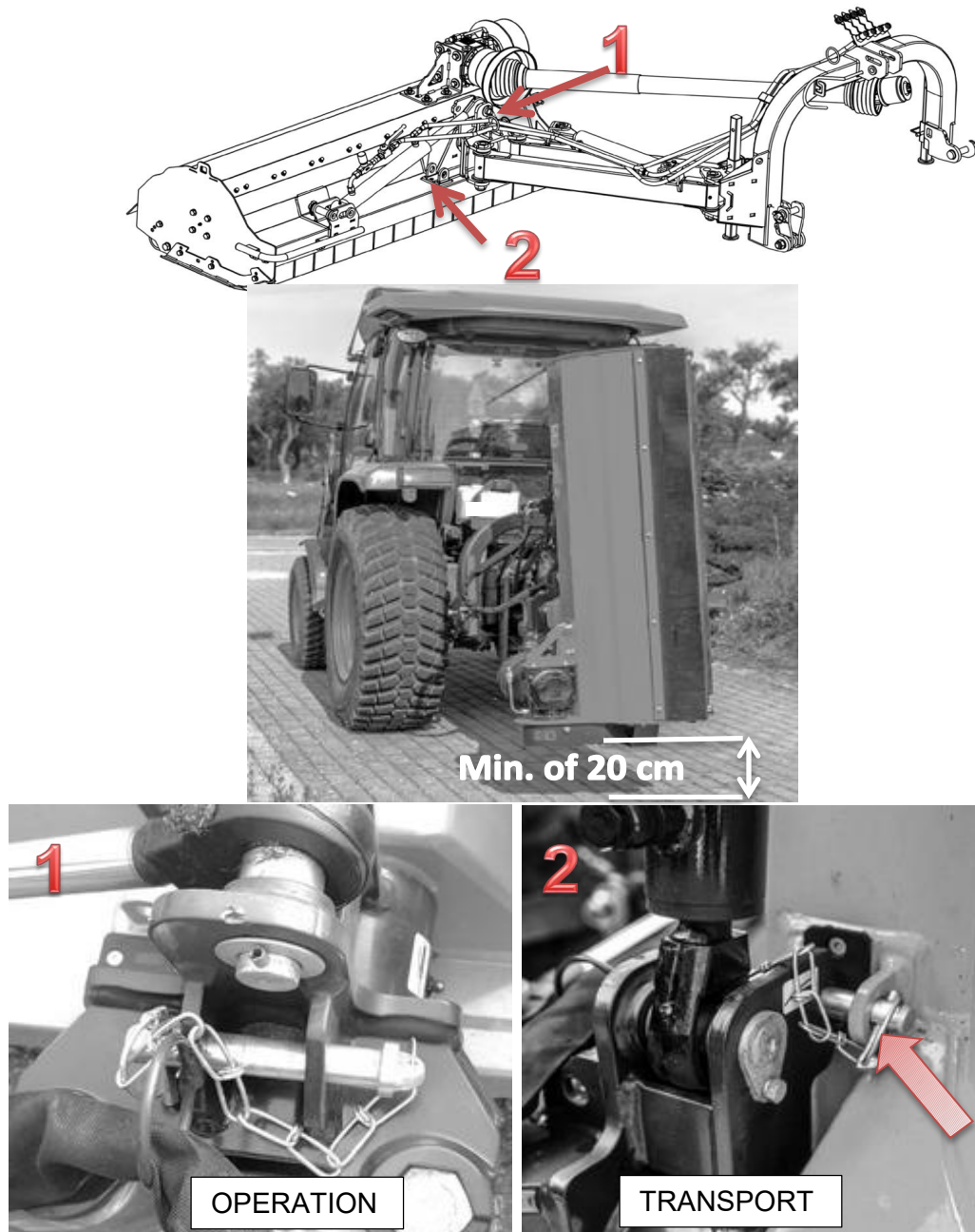
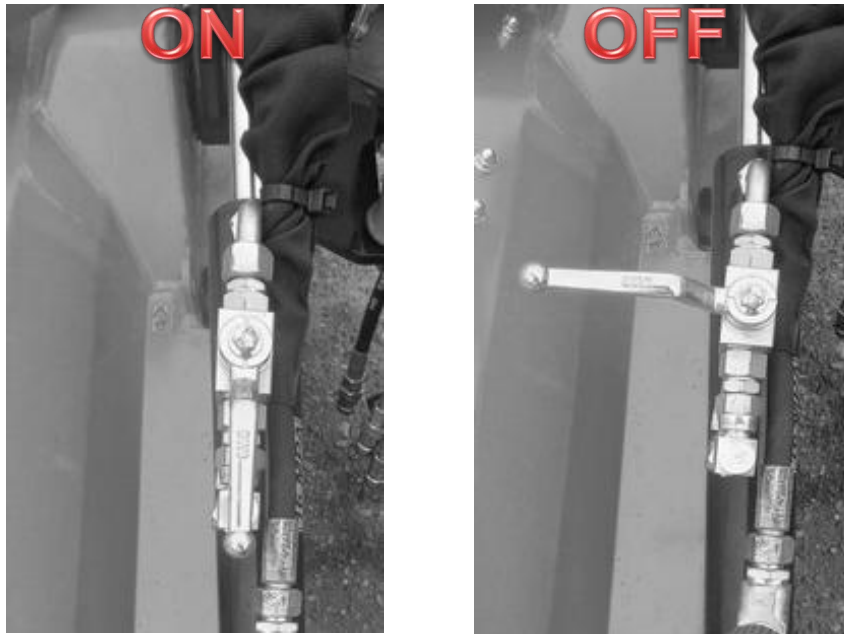

Figure 9. Vertical transport position

- If the mower has been fitted with a ball valve on the cylinder, it is important to ensure that it is correctly adjusted during transport and operation. During transport, the valve must always be in the closed (OFF) position and during operation in the open (ON) position, as shown in Figure 10.



**Figure 10. Position of ball valve during operation and transport**

#### 4.3. **Mowing height adjustment using the running shaft**

Changing the cutting height requires a change to the position of the running shaft. In order to do this, lift the machine, secure it against falling and moving. The cutting height ranges from approximately 0.75" to 2.00". The shaft can be adjusted 4 stages by turning an M16 screw in 1 of the 4 holes. Start the adjustment by loosening the M16 screw marked "A" in Figure 11. The screw marked "B" must be unscrewed and inserted into the appropriate hole. The operations must be carried out on both sides of the shaft using the coaxial holes in both sides. When repositioning the screws, remember that the shaft will fall down under its own weight and that it is necessary to support it to ensure safe handling. Repositioning the screw by 1 hole results in a cutting height change of approximately 0.50".

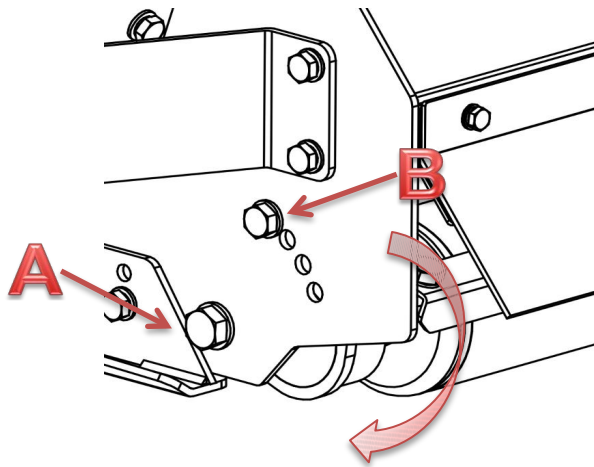

Figure 11. Driving shaft adjustment

-While switching the machine from the transport position to the working position and back, no one is allowed to stay in the zone of moving elements.



-When adjusting the machine, the tractor must be switched off, the ignition key removed and the parking brake applied.

#### 4.4. **Cylinder extension speed adjustment.**

If the machine has been fitted with a throttle valve, it is possible to adjust the speed of the cylinder extension on the body. The movement of the cylinder when lowering the machine should be slow enough not to damage the bearings on the jockey/running shaft when it hits the ground. To adjust, turn the valve knob according to the markings. After adjustment, tighten the locking screw on the valve.

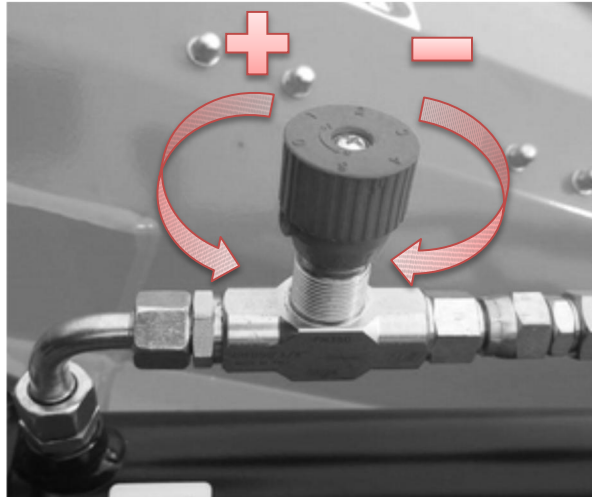

Figure 12. Cylinder extension speed adjustment

#### 4.5. Operation



The machine can be started once it is supported on the ground. It is prohibited to engage the drive when the machine is raised above the working surface and not resting on the ground. It is prohibited to lift a running machine on a hoist. Disconnect the drive and wait until rotation stops before lifting the machine.

The operation speed depends on the field conditions and should be adapted to them to ensure satisfactory work quality.

It is also necessary to do the following each time before the work is carried out:

- Check the general condition of the machine
- Check the condition of the connections.
- Check the power hydraulic system for damage or leaks.

### 5. Recommended machine operation

#### 5.1. Oil change points

Change the oil in the angular gearbox at least once a year. The quantity of oil to be changed and its specifications are shown below:

	Oil quantity	Oil specifications
Gearbox	1.5L	GL-4 80W90

The oil change points are marked in Figure 13, where “A” indicates the oil filling inlet and “B” the drain plug.

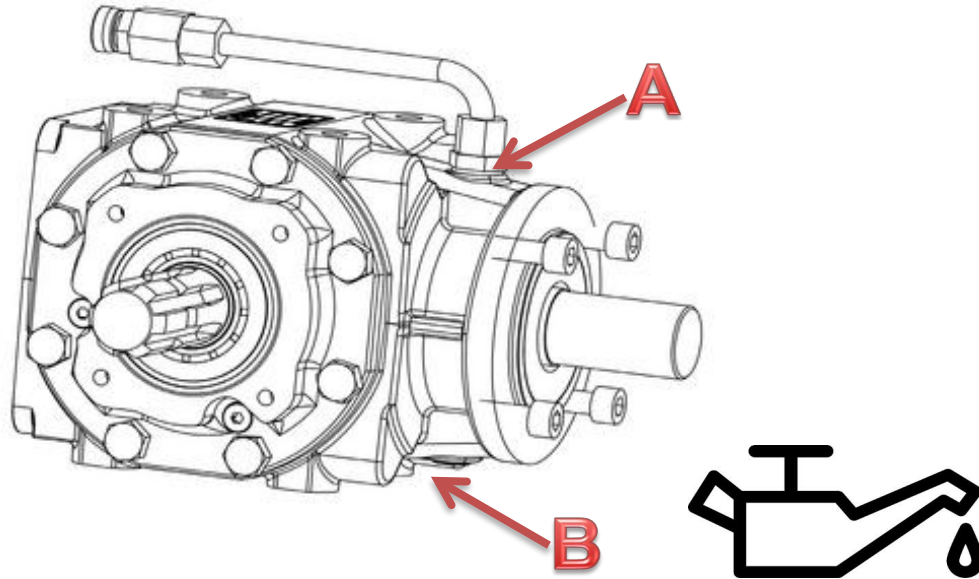

Figure 13. Oil change points

## 5.2. *Lubrication points*

To ensure the correct performance of the machine, it must be thoroughly and properly lubricated according to the lubrication diagram.

All points indicated in Figure 14, equipped with ball type grease fittings, should be filled with solid grease  $\text{LT43}$  using of a lubricating gun. Lubricate the jointed-telescopic shaft after removing it from the machine. Lubricate the telescopic part of the shaft at least after 8 hours of operation – when the shaft is entirely moved apart and impurities have already been cleaned. Details of PTO shaft operation are contained in a separate manual supplied with it.

The figure 14 presents the location and recommended operating time after which the indicated components should be lubricated.

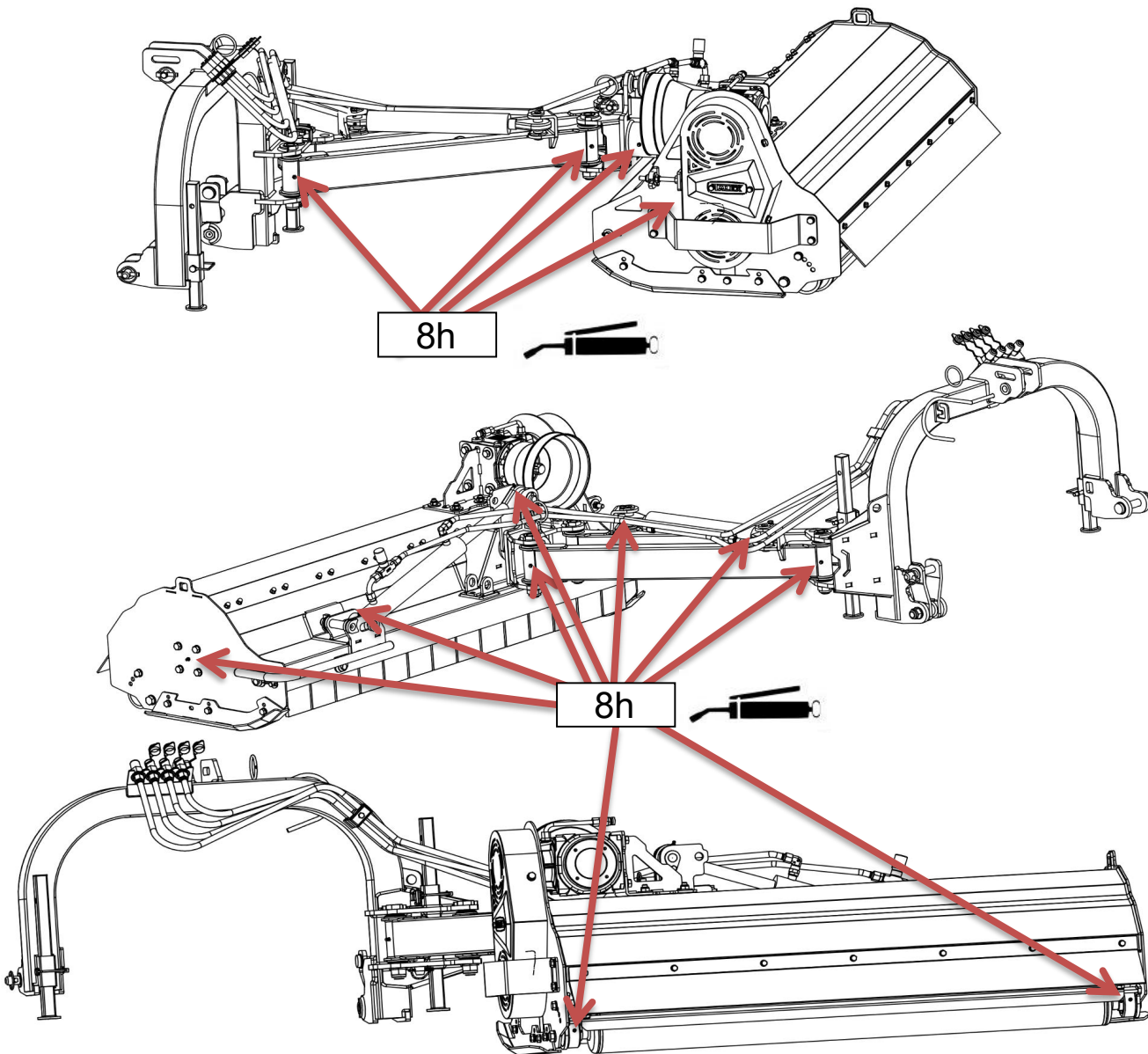

Figure 14. Lubrication diagram

### 5.3. *Tensioning of the V-belts*

To check the belts, the belt cover or at least the visor in the cover must first be removed. Correctly tensioned belts yield approximately 0.50" pressure, which is roughly equivalent to thumb pressure used if specialist belt tension gauges are not available.

To tension the belts, loosen the M12 nut marked "A" and the M14 bolt marked "B" in Figure 15. Then, using the M12 nut marked "C", tighten the belts as indicated by the arrow. Once the outlined actions have been performed, tighten both nuts and the bolt and finally replace the cover.

When replacing the belts, check their general condition, in addition to verifying with a spirit level or other flat object that the upper and lower belt pulleys are flush. If the belts are found to be damaged, they must be replaced with new ones.

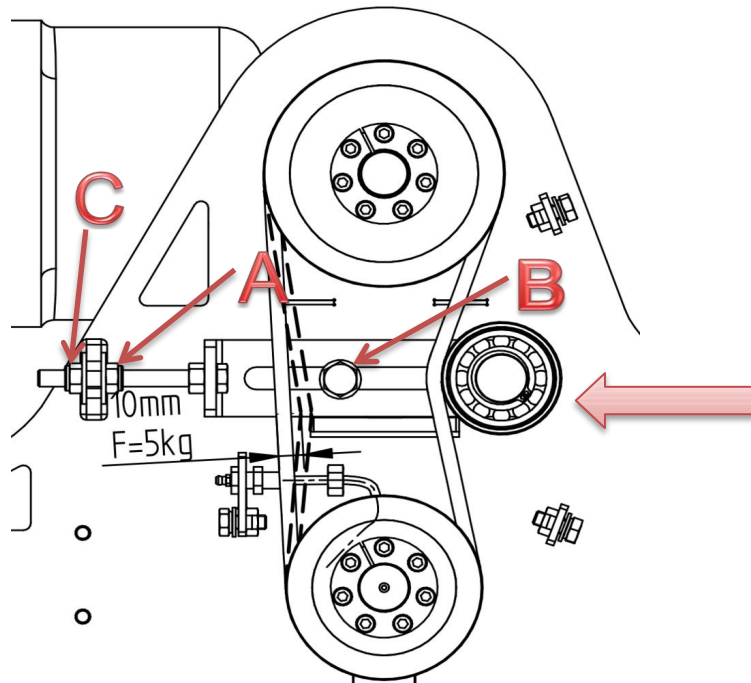
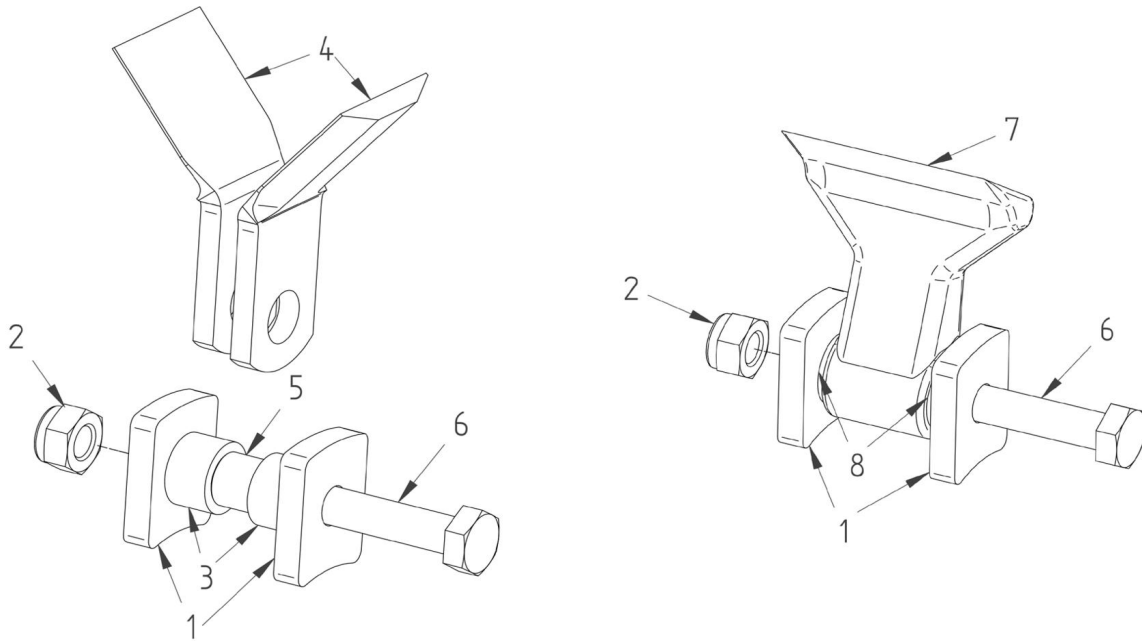

Figure 15. Belt tensioning diagram

#### 5.4. **Changing cutting tools**

Depending on the customer's requirements, the working shaft is equipped with the appropriate equipment in the form of cutting tools. These tools are shown in Figure 16, where the individual components are numbered:

- 1-Mounting on the working shaft welded to the shaft tube (non-replaceable part, only available as a whole shaft).
- 2-M14 self-locking nut (part no.: LNM1415)
- 3-knife spacer bushing (part no.: FZ10148)
- 4-knife (part no.: FZ10146)
- 5-Sleeve (part no.: FZ10147)
- 6-M14x90 special bolt (part no.: FZ10141)
- 7-hammer (part no.: FZ10143)
- 8-washer (part no.: FZ10142)



**Figure 16.** Cutting tool assembly

The cutting tools must be replaced if defects, noticeable signs of wear, blunting of the cutting edges, missing blades or flails, or excessive play of the mounted tools are identified.



**Maximum cutting tool play**

Play	Nominal [mm]		Permissible [mm]	
	Knife	Flail	Knife	Flail
Transverse axial	0.2	0.3	0.5	0.6
Longitudinal axial	0.1	0.2	0.4	0.6

The cutting tools must be replaced in compliance with the specific safety rules.

1. Use only the original and functional parts for the cutting units.
2. Always replace full sets of tools. You must remember about the uniform distribution of the rotating masses, to ensure the uniform wear of the tools.
3. The bolted connections need to be replaced with new ones each time the tools are replaced, paying attention to the resistance class of the bolt and the self-locking nut.
4. When tightening the bolt connection, pay attention to the free (without excessive play) rotation of the cutting tool in relation to the bolt axis.

In addition, as part of the overall service:



- V-belts and hydraulic lines should be replaced every 5 years.
- Check the condition of the belts and bolted connections after approximately 5 initial hours of operation. Check the condition of the bolted connections every 10 hours of operation.
- Clean the machine after each working day, especially the lubrication points.

## 6. Technical inspections, storage, disposal

Every day, at the end of work, clean the mower carefully and check its technical condition. Pay special attention to the condition of the flails and knives. Damaged or worn parts must be replaced with new ones. Check all the bolted connections and tighten loose connections, according to the table of tightening torque values for bolts and nuts. If coating defects are identified, they should be remedied with a new coat of paint.

**Tightening torque values for bolts and nuts**

Property class	6.8	8.8	10.9	12.9
Metric thread	Tightening torque [Nm]			
M6	7,2	9,5	14	16,5
M8	17,5	23	34	40
M10	35	46	68	79
M12	60	79	117	135
M14	95	125	185	215
M16	147	195	280	330
M18	202	280	390	460
M20	284	390	560	650
M22	385	530	750	880
M24	490	670	960	1120
M27	725	1000	1400	1650
M30	990	1300	1830	2200

Comments:

1. The table shows the maximum tightening torques (in accordance with ISO 898/1) that bolts and screws should withstand without plastic deformation upon loosening.
2. In the case of using lubricants or coatings that reduce the friction coefficient on the thread and under the bolt head, a tightening torque of 70% of the values given in the table should be used.

After the end of the operating season:

- carefully clean the machine,
- carry out technical inspection and replace the damaged parts with new ones available from the manufacturer,
- lubricate the machine according to the lubrication diagram (Fig. 14),
- remedy defects in the protective coating.



All repairs and replacements of parts of the mower drive system should be carried out by a proper workshop equipped with appropriate tools and instruments.

### 6.1. Storage

Store the mower in a dry place, sheltered from the weather.

The machine should be placed on a stable, level surface and protected against uncontrolled movement.

### 6.2. Dismantling and disposal

If the machine becomes worn to the extent which prevents its further use, it should be disposed of. This also applies to regular repairs and replacement of damaged parts. To do this, the machine must be thoroughly cleaned, its operating fluids removed and sent for disposal. Next, disassemble the machine by segregating its parts according to the materials used in them. The segregated parts should be taken to a recycling or a disposal center

### 6.3. Stability

In order to verify the overall stability, the following formula may be used to calculate the minimum additional front load  $I_{F,min}$  expressed in kg, enabling the front axle load equal to 20% of the tractor weight to be achieved.

$$I_{F,min} = \frac{[I_R \times (c+d)] - (T_F \times b) + (0,2 \times T_E \times b)}{a+b}$$

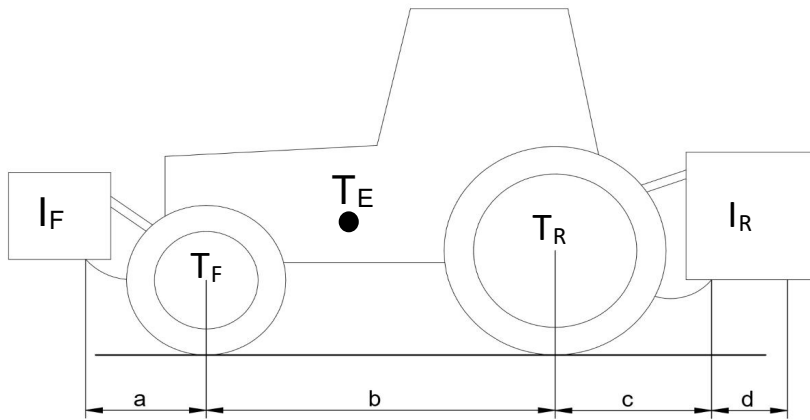

Explanations:

$T_E$ -empty tractor weight [kg]

$T_F$ -front axle pressure, empty tractor [kg]

$T_R$ -rear axle pressure, empty tractor [kg]

$I_F$ -weight of the machine hitched in the front/front weights[kg]

$I_R$ -weight of the machine hitched in the rear/rear weights[kg]

$a$ -distance between the center of gravity of the front-hitched machine/front weights and the center of the front axle [m]

$b$ -tractor wheelbase [m]

c-distance between the center of the rear axle and the center of ball joints of the rear suspension [m]

d-distance between the center of the rear suspension ball joints and the centre of gravity of the rear-hitched machine/rear weights [m]

## 7. Spare parts catalog

### SPARE PARTS ORDERING PROCEDURE

Each order form should include the following:

- address of the buyer;
- exact shipping address (place where machine is located or other means for delivery collection);
- terms of payment;
- serial number of the machine and the year of manufacture (acc. to the nameplate on the machine);
- spare part number;
- spare part name;
- number of parts ordered.



Spare parts must be ordered at the points of sale of the machines or from the manufacturer. Use only the original spare parts provided by the manufacturer, to guarantee safe and reliable operation of the machine. The use of not original spare parts or parts, which have been repaired, will render the warranty void.

The manufacturer reserves the right to introduce changes to the design of parts presented in the particular assembly drawings in this spare parts catalog. Such changes may not always be updated in the manual and the spare parts catalog. Individual drawings may differ from the actual look of the parts.

### **Distributor Address**

### **Belco Resources Equipment**

401 Jeffrey's Road

Rocky Mount, NC27804

tel.: (252) 822-7140

e-mail: [sales@br-equipment.com](mailto:sales@br-equipment.com),  
or [www.br-equipment.com](http://www.br-equipment.com)

## 7.1. General design

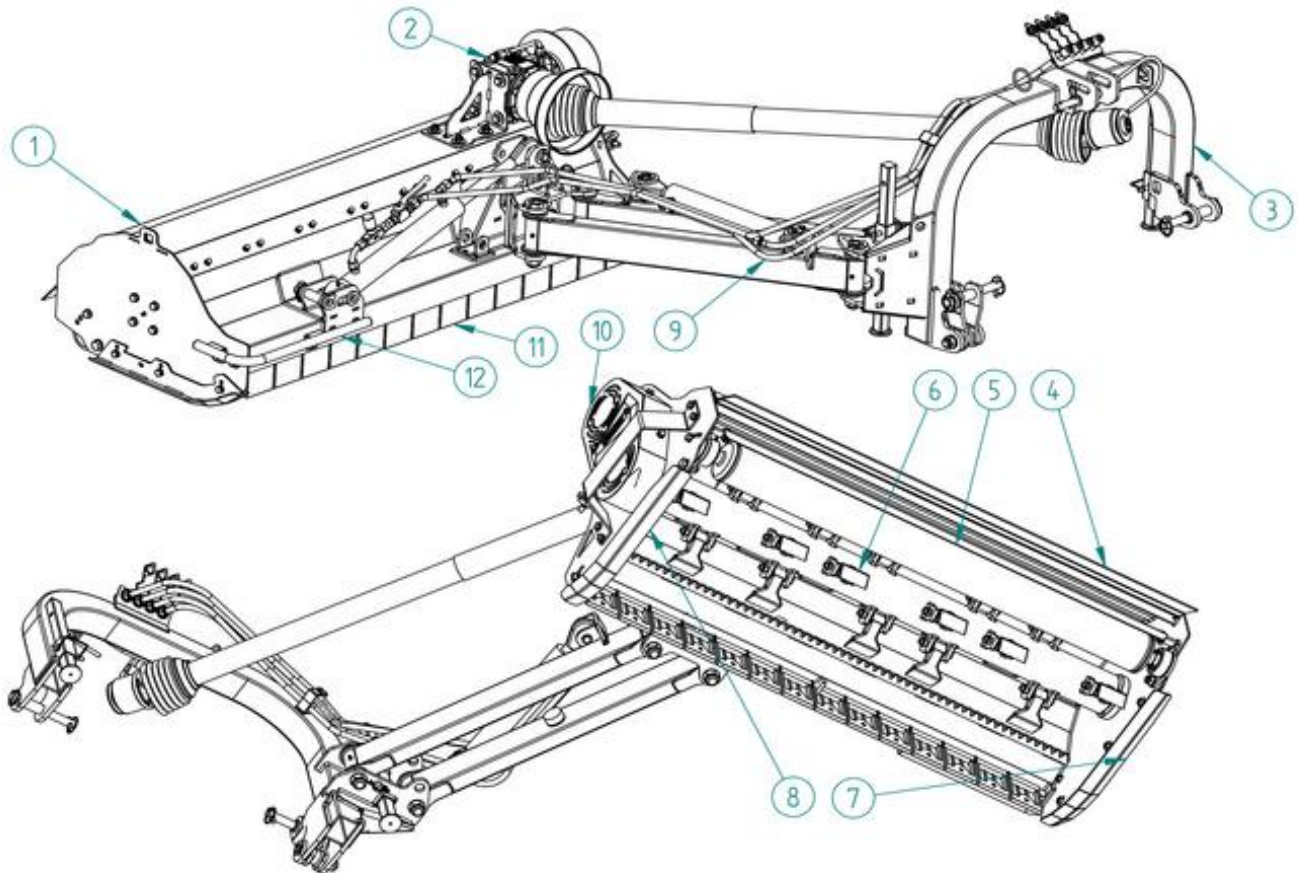

Item	Name	Index/Section	Qty
1.	Body; Katana-65	FZ10102	1
2.	Drive system	Section 7.2	1
3.	Hitch suspension system	Section 7.3	1
4.	Rear curtain	Section 7.4	1
5.	Running gear	Section 7.5	1
6.	Work assembly	Section 7.6	1
7.	Right slider	Section 7.7	1
8.	Left slider	Section 7.8	1
9.	Hydraulic system	Section 7.9	1
10.	Belt transmission shield	Section 7.10	1
11.	Front curtain	Section 7.11	1
12.	Other	Section 7.12	1

## 7.2. Drive system

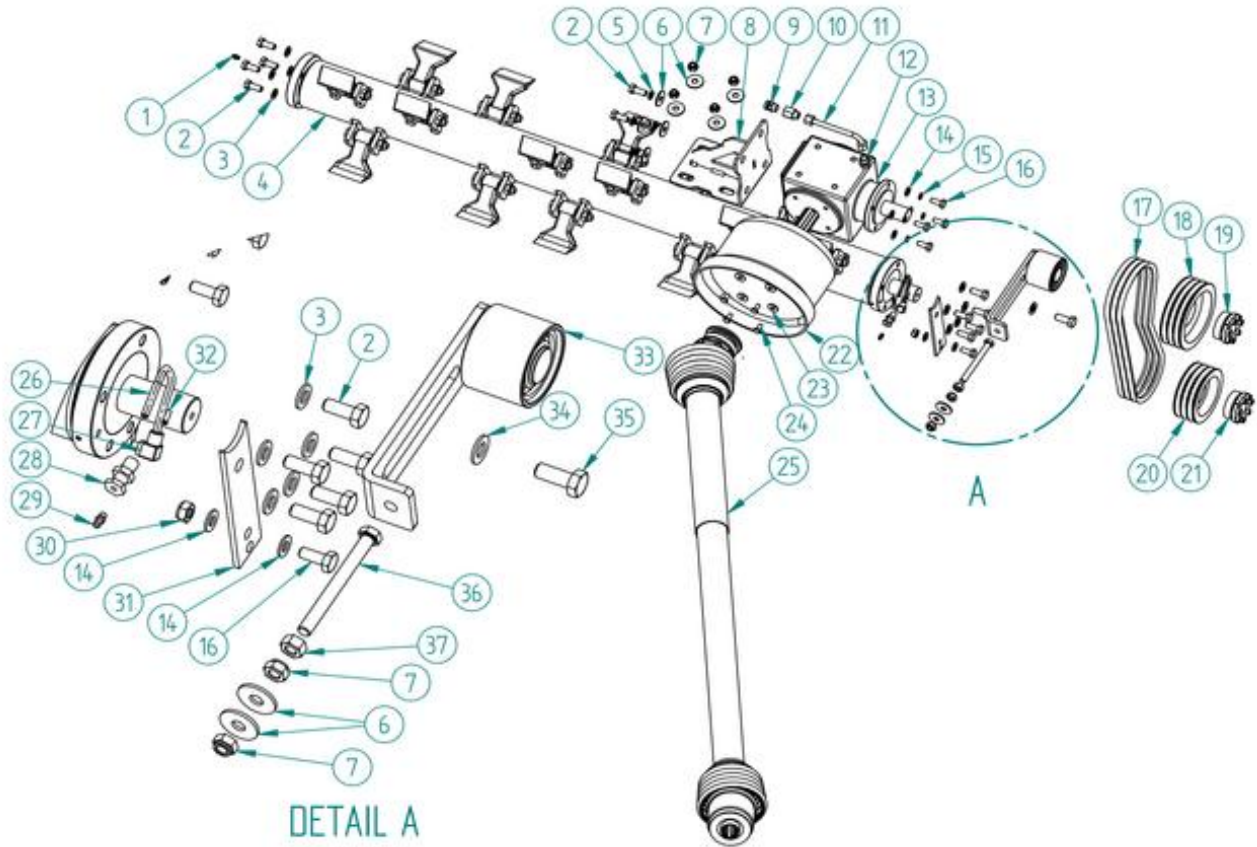

Item	Name	Index/Section	Qty
1.	Grease nipple M8x1	GN081S	1
2.	Bolt M12x30-8.8	BM1212530	9
3.	M12 regular washer	FW12	9
4.	Work assembly	Section 7.6	
		Katana-65	1
5.	Spring washer M12	LW12	4
6.	Extensional washer M12	LFW12	10
7.	M12 self-locking nut	LNM12125	6
8.	Gearbox base	FZ10103	1

9.	Air vent	FZ10024	1
10.	Reduction M16x1.5-G3/8	FZ10023	1
11.	Gearbox vent pipe	FZ10022	1
12.	Connector G3/8-M16x1.5 Straight connector M16x1.5 - M16x1.5 ED/10L	FZ10020 FZ10021 *	1
13.	Gearbox	FZ10010	1
14.	M10 regular washer	FW10	4
15.	Spring washer M10	LW10	4
16.	Bolt M10x25-8.8	BM1012525	4
17.	Belt; Katana-65		
		Katana-65	FZ10104
18.	Pulley 160; Katana-65		
		Katana-65	FZ10105
19.	Clutch D33; Katana-65		
		Katana-65	FZ10106
20.	Pulley 130; Katana-65		
		Katana-65	FZ10107
21.	Clutch D35; Katana-65		
		Katana-65	FZ10108
22.	PTO guard	FZ10017	1
23.	Extensional washer M8	LFW08	4
24.	Bolt M8x16-8.8	BM0812516	4
25.	PTO shaft; Katana-65		
		Katana-65	FZ10016
26.	Polyamide hose	FZ10012	0.16 m
27.	M8x1 rotary quick-coupling	FZ10011	1
28.	Bulkhead connection	FZ10110	1
29.	Grease nipple M6x1	GN061S	1
30.	M10 self-locking nut	LNM10125	1
31.	Working shaft plug	FZ10111	1
32.	Insert sleeve	FZ10014	1
33.	Belt tensioner; Katana-65		
		Katana-65	FZ10112
34.	M14 regular washer	FW14	1
35.	Bolt M14x35-8.8	BM141535	1
36.	Bolt M12x110-8.8	BM12125110	1
37.	Nut M12	NM12125	1

\*depends on the gear box type used

### 7.2.1. Belt tensioner

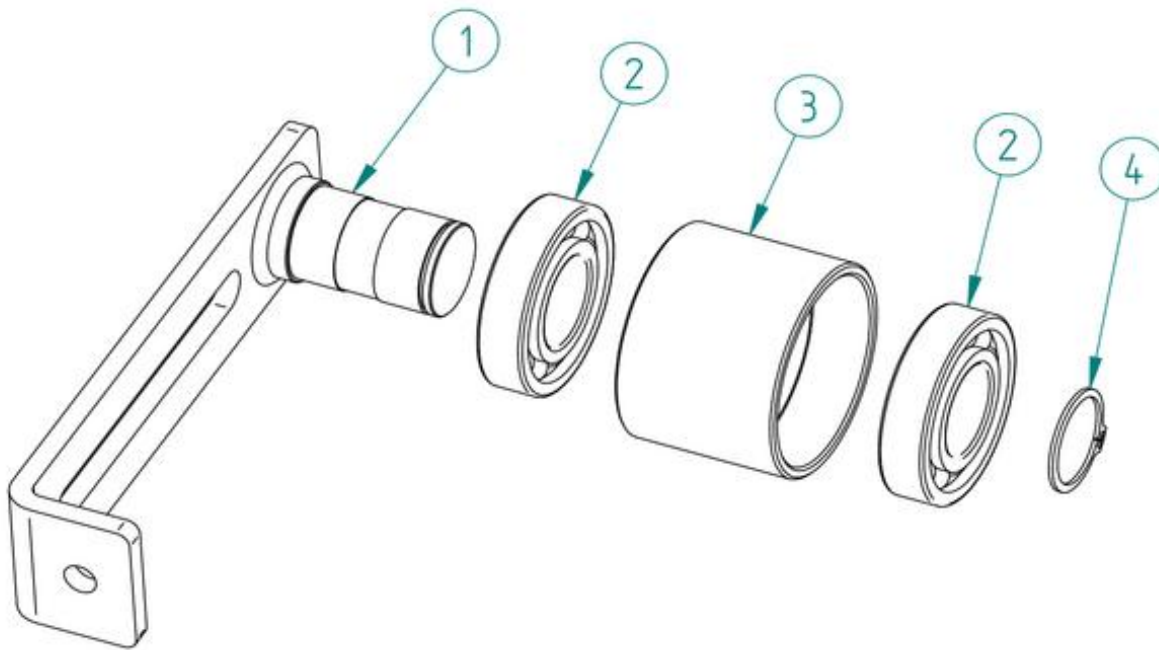

Item	Name	Index	Qty
1.	Tensioner arm; Katana-65		1
		Katana-65	
2.	Bearing 6207 2RS C3	B6207-2RS	2
3.	Tensioner roller; Katana-65		1
		Katana-65	
4.	Snap ring Z35	SRE-35	1

### 7.3. Hitch suspension system

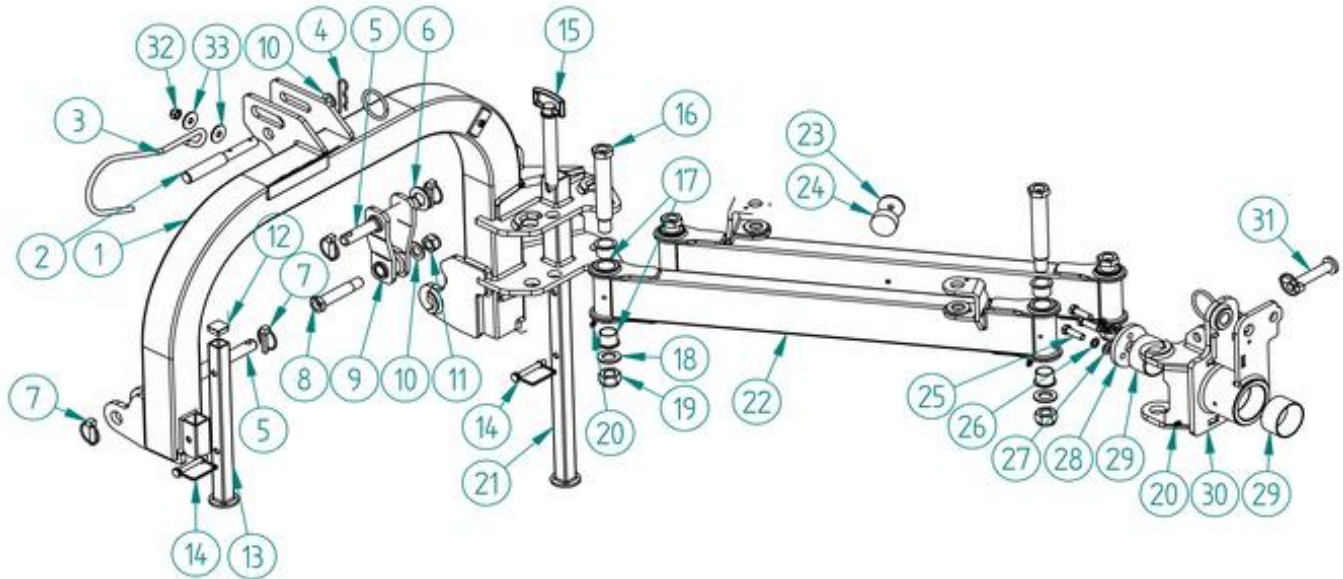

Item	Name	Index	Qty
1.	Suspension	FZ10115	1
2.	Upper grapple pin	FZ10116	1
3.	PTO shaft hanger	FZ10046	1
4.	Beta pin double	FZ10117	1
5.	Lower suspension pin	FZ10118	2
6.	M27 regular washer	FW27	1
7.	LP10KR universal plug	FZ10119	4
8.	Suspension pin - safety	FZ10120	1
9.	Swing eye-safety assembly	FZ10121	1
10.	M20 regular washer	FW20	2
11.	M20 self-locking nut	LNM2025	1
12.	Stopper 30x30x1-3	FZ10026	2
13.	Shorter support foot	FZ10122	1
14.	Cotter pin LPS1267GP	FZ10027	2
15.	KD/KDC pin cpl.	FZ10123	1
16.	Arm pin	FZ10124	4
17.	30260 sliding sleeve	FZ10038	8

18.	M24 regular washer	FW24	4
19.	M24 self-locking nut	LMN2415	4
20.	Grease nipple M8x1	GN081S	5
21.	Longer support foot	FZ10048	1
22.	Arm	FZ10125	2
23.	Buffer spacer	FZ10126	1
24.	Buffer	FZ10127	1
25.	Bolt M12x40-8.8	BM121540	3
26.	Spring washer M12	LW12	3
27.	M12 regular washer	FW12	3
28.	Turntable protection	FZ10128	1
29.	Sliding sleeve 75x70x40	FZ10129	2
30.	Turntable	FZ10130	1
31.	Pin $\varnothing$ 19	FZ10045	1
32.	M12 self-locking nut	LMN1215	1
33.	M12 large size washer	LFW12	2

#### 7.4. Rear curtain

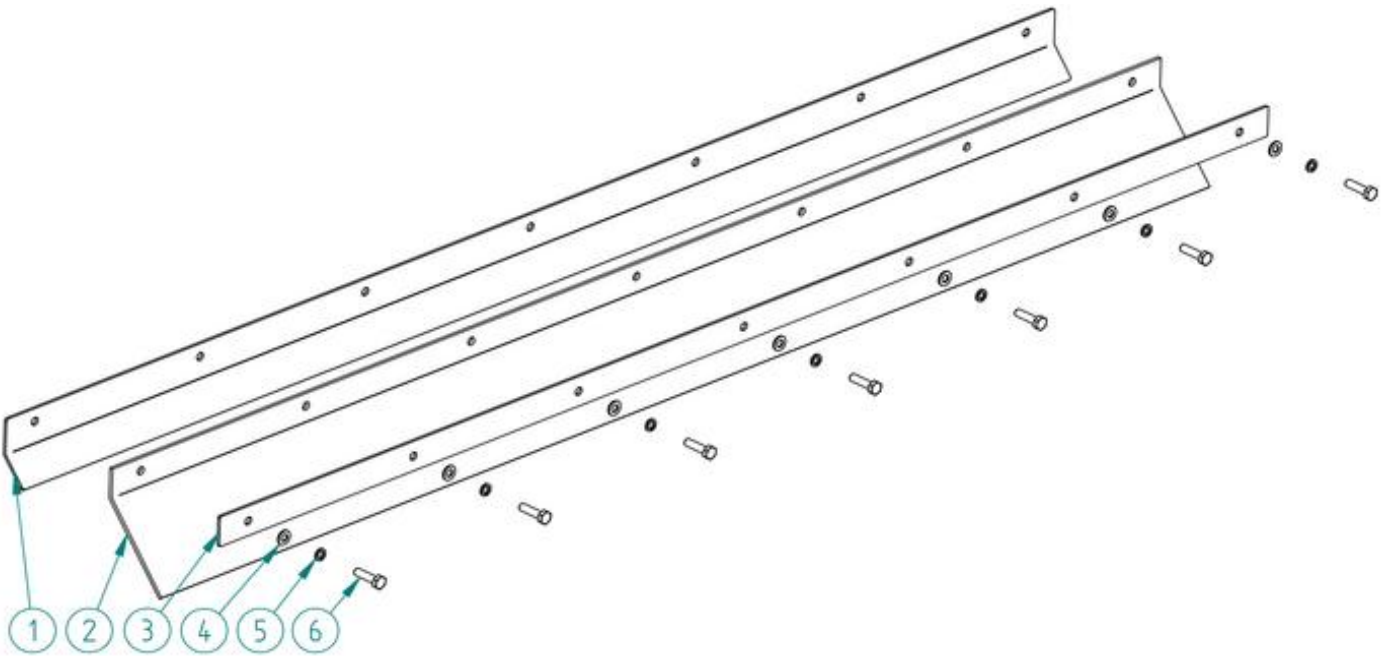

Item	Name	Index	Qty
1.	Rear curtain angle profile; Katana-65	FZ10131	1
2.	Rubber cover; Katana-65	FZ10132	1
3.	Rear curtain flat strip; Katana-65	FZ10133	1
4.	M8 regular washer	FW08	8
5.	Spring washer M8	LW08	8
6.	Bolt M8x30-8.8	BM0812530	8

## 7.5. Running gear

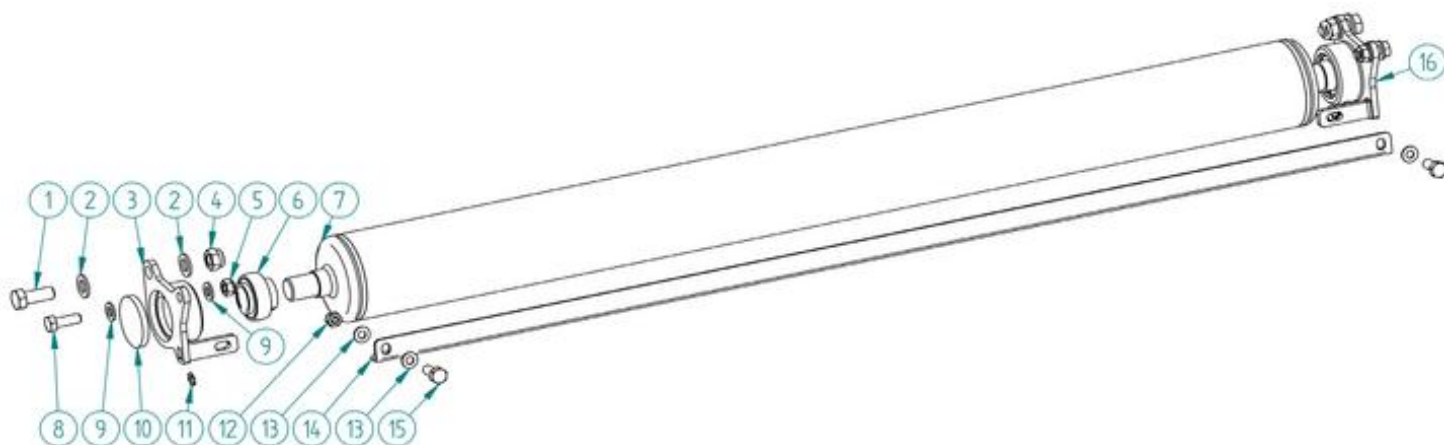

Item	Name	Index	Qty
1.	Bolt M16x40-8.8	BM161540	2
2.	M16 regular washer	FW16	4
3.	Left drive shaft mounting	FZ10134	1
4.	M16 self-locking nut	LN1615	2
5.	M12 self-locking nut	LN1215	2
6.	Bearing UC206	B206UC	2
7.	Drive shaft; Katana-65	Katana-65 FZ10135	1
8.	Bolt M12x35-8.8	BM1212535	2
9.	M12 regular washer	FW12	4
10.	Cap 68x8	FZ10136	2
11.	Grease nipple M6x1	GN0615	2
12.	M10 self-locking nut	LN1015	2
13.	M10 regular washer	FW10	4
14.	Scraper; Katana-65	Katana-65 FZ10137	1
15.	Bolt M10x30-8.8	BM101530	2
16.	Right drive shaft mounting	FZ10138	1

## 7.6. Work assembly

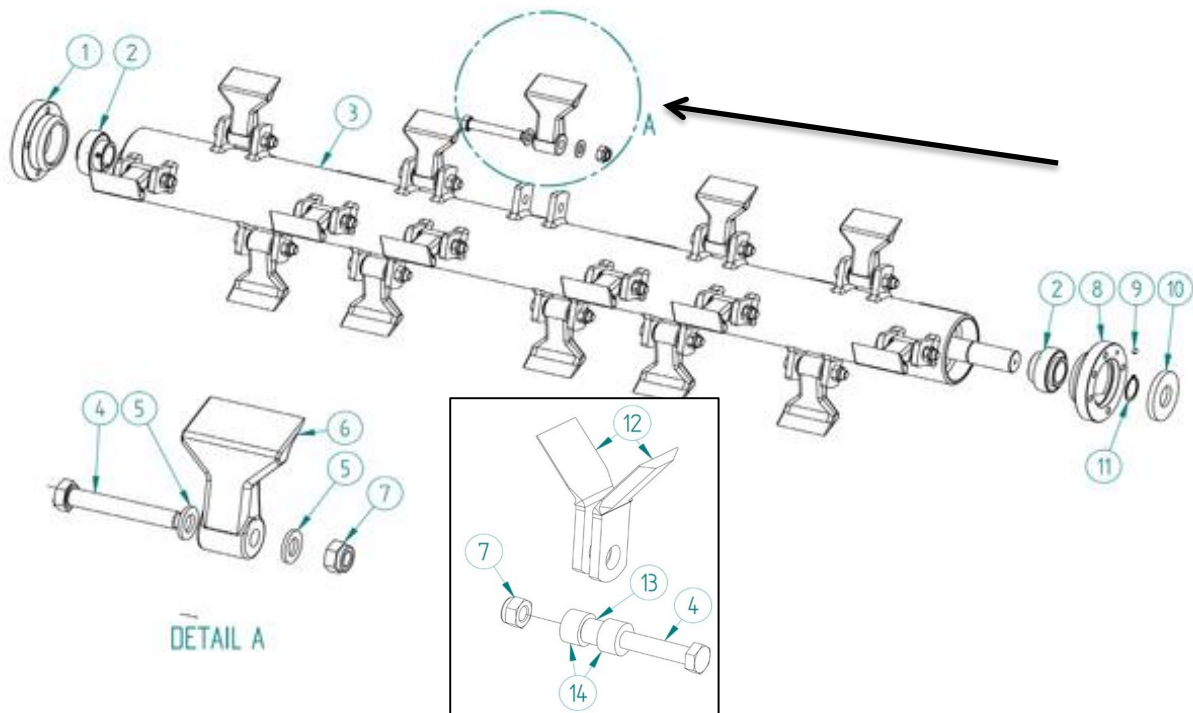

Item	Name	Index	Qty
1.	Working shaft bearing housing	FZ10139	1
2.	Bearing shaft	BUC207	2
3.	Working shaft	FZ10140	1
4.	M14x90-10.9 screw, special version	FZ10141	26
5.	Hammer washer	FZ10142	52
6.	Hammer	FZ10143	26
7.	M14 self-locking nut	LNМ1415	26
8.	RBM working shaft bearing housing	FZ10144	1
9.	Grub screw M6x8	FZ10145	1
10.	Seal 35x80x10	OS358010	1
11.	Snap ring Z35	SRE-35	1
12.	Knife	FZ10146	52
13.	20x14.5 sleeve	FZ10147	26
14.	Spacer bushing	FZ10148	52

### 7.7. Right slider

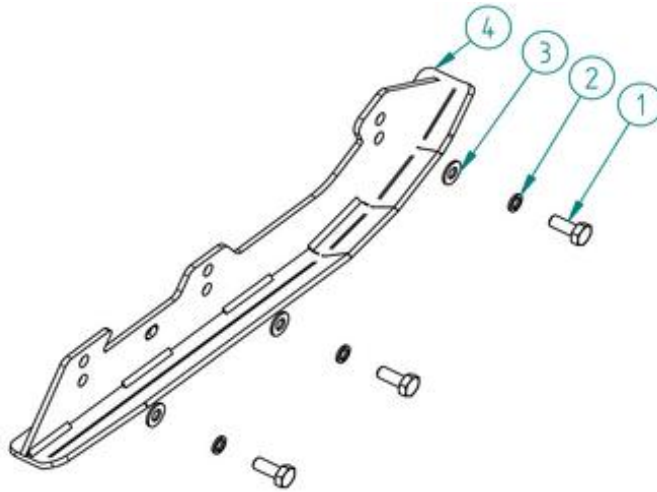

Item	Name	Index	Qty
1.	Bolt M10x25-8.8	BM1012525	3
2.	Spring washer M10	LW10	3
3.	M10 regular washer	FW10	3
4.	Right slider; Katana-65	FZ10149	1

### 7.8. Left slider

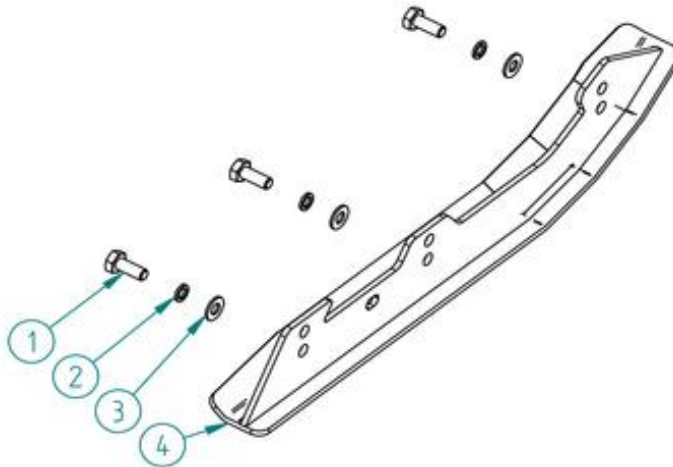

Item	Name	Index	Qty
1.	Bolt M10x25-8.8	BM1012525	3
2.	Spring washer M10	LW10	3
3.	M10 regular washer	FW10	3
4.	Left slider; Katana-65	FZ10150	1

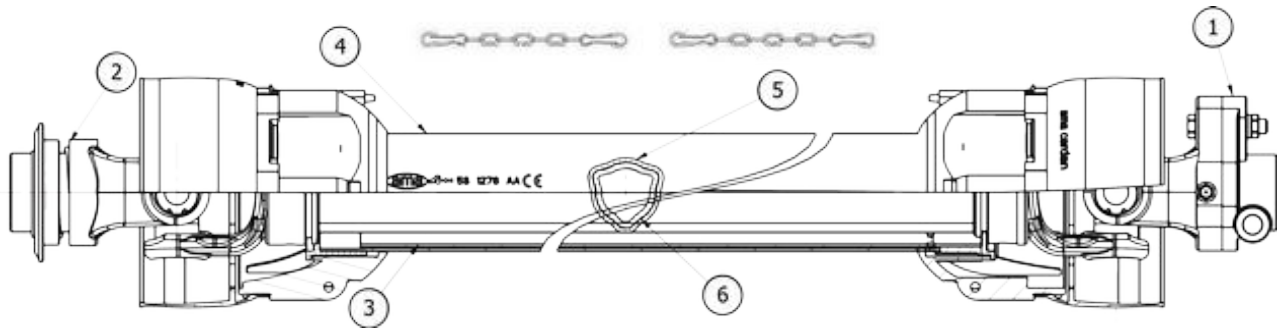

PTO Driveline

Item	Name	Index	Qty
1.	Yoke assembly (implement end) - FZ10016, PTO complete	FZ10131	1
2.	Yoke assembly (tractor end) - FZ10016, PTO complete	FZ10132	1
3.	Inner guard tube - FZ10016, PTO complete	FZ10133	1
4.	Outer guard tube - FZ10016, PTO complete	FZ10336	1
5.	Outer tube - FZ10016, PTO complete	FZ10037	1
6.	Inner tube - FZ10016, PTO complete	FZ10038	1
-	Locking collar, for PTO FZ10016	FZ10339	1
-	PTO complete 620Nm L=1500 w/shear bolt	FZ10016	1

## 7.9. Hydraulic system

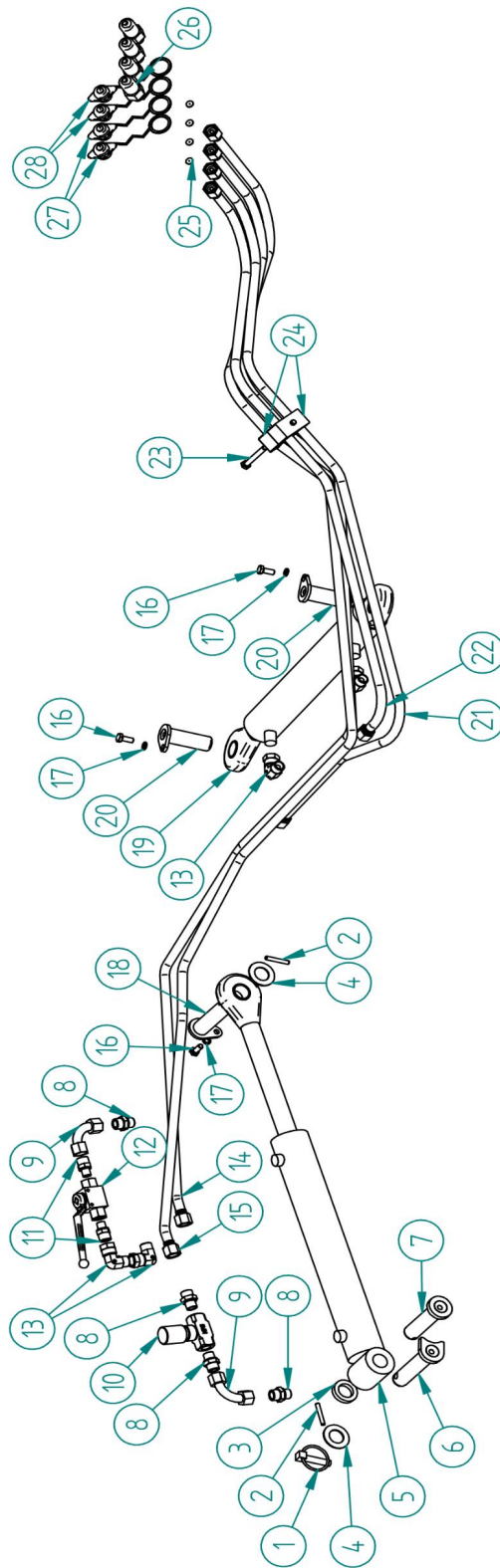

Item	Name	Index	Qty
1.	Folding pin	FZ10041	1
2.	Spring-type straight pin 6x40	FZ10075	2
3.	Pin washer	FZ10151	1
4.	Washer M25	FW25	2
5.	Body positioning cylinder	FZ10074	1
6.	Cylinder lock pin	FZ10152	1
7.	Cylinder-body pin	FZ10153	1
8.	Straight connector G3/8"/M18x1.5 ED/12L	FZ10076	4
9.	Arc fitting AA	FZ10080	2
10.	Throttling valve	FZ10154	1
11.	Straight connector G1/4-M18x1.5	FZ10078	2
12.	Ball valve 2/2-1/4	FZ10079	1
13.	Elbow fitting AB	FZ10077	4
14.	Cable 1/2/P51 L-3375	FZ10082	1
15.	Cable 1/2/P51 L-3625	FZ10081	1
16.	Bolt M8x20-8.8	BM0812525	3
17.	Spring washer M8	LW08	3
18.	Cylinder-turntable pin	FZ10155	1
19.	Arm positioning cylinder	FZ10087	1
20.	Arm cylinder pin	FZ10156	2
21.	Cable 1/2/P51 L- 2300	FZ10084	1
22.	Cable 1/2/P51 L- 2000	FZ10085	1
23.	Bolt M8x60 -8.8 GALV	BM0812560	1
24.	Bracket 2x15	FZ10088	2
25.*	Choke 9.8x1	FZ10089	4
26.**	1/2 quick fit coupling plug	FZ10092	4
27.	Yellow dust cap	FZ10090	2
28.	Black dust cap	FZ10091	2

\*in some models may be located on the cylinder side

\*\*the quick fit couplers come complete with a washer(T004392)

7.10. *Belt transmission shield*

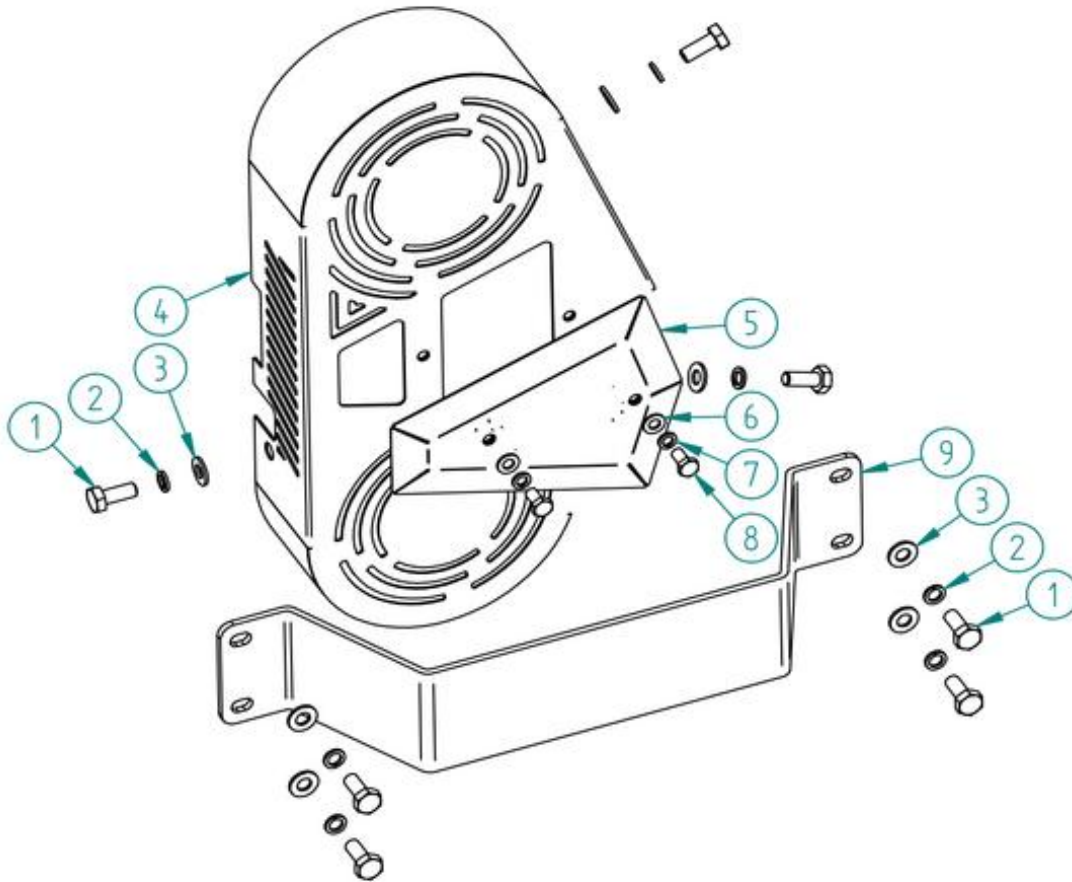

Item	Name	Index	Qty
1.	Bolt M10x25-8.8	BM1012525	7
2.	Spring washer M10	LW10	7
3.	M10 regular washer	FW10	7
4.	Belt shield; Katana-65		
	Katana-65	FZ10157	1
5.	Sight glass	FZ10158	1
6.	M8 regular washer	FW08	2
7.	Spring washer M8	LW08	2
8.	Bolt M8x16-8.8	BM0812516	2
9.	Side slide; Katana-65		
	Katana-65	FZ10159	1

7.11. **Front curtain**

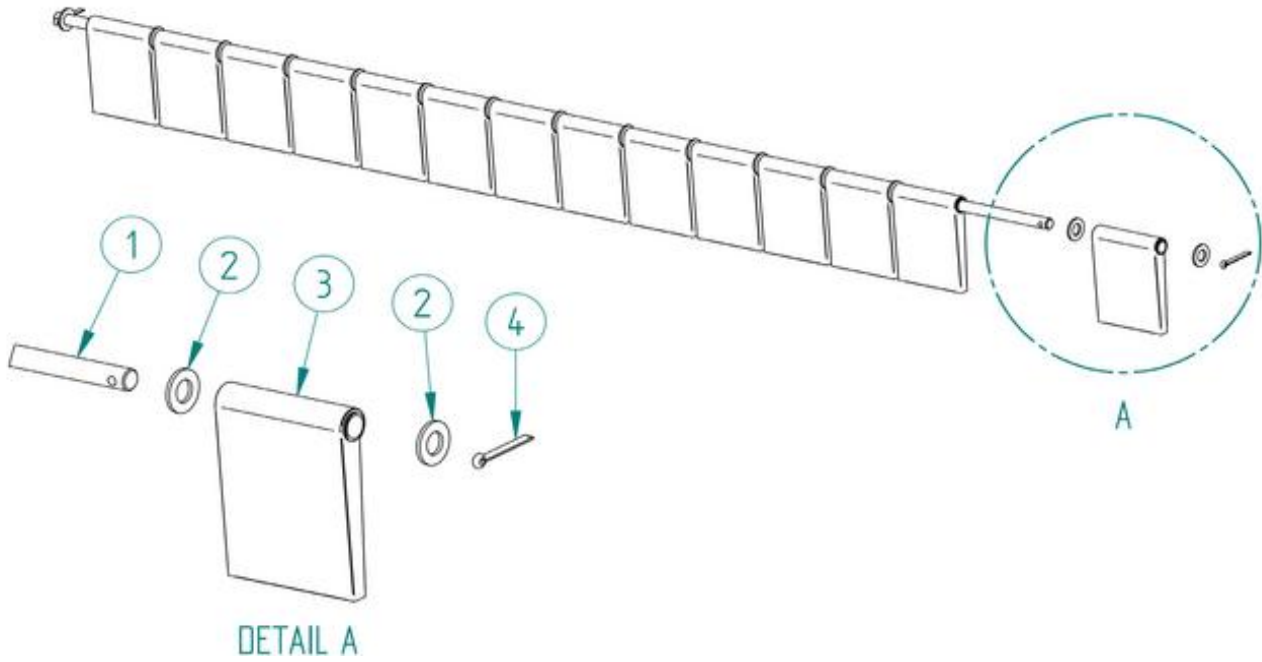

Item	Name	Index	Qty
1.	Front curtain rod; Katana-65		
		Katana-65	FZ10160
2.	M14 regular washer		
		Katana-65	FW14
3.	Curtain shield		
		Katana-65	FZ10161
4.	Cotter pin 5x40	CP5x40	2

\*quantity may vary due to adjustments during assembly of the machine

## 7.12. Other

### 7.12.1. Turntable buffer

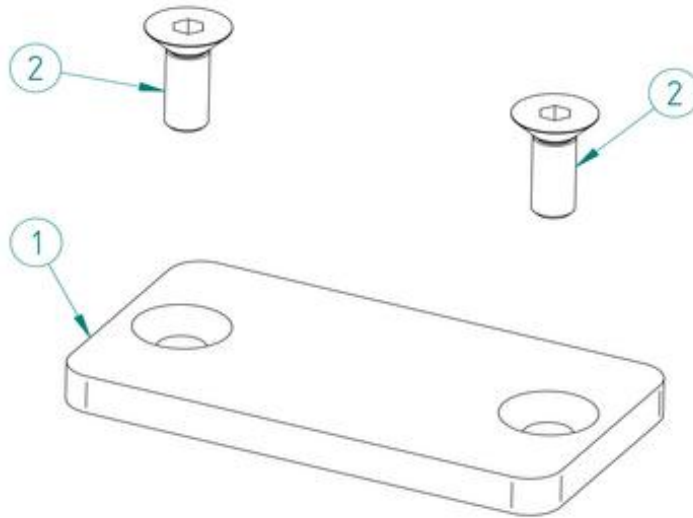

Item	Name	Index	Qty
1.	Turntable buffer	FZ10162	1
2.	Countersunk bolt M6x16-8.8	FZ10165	2

### 7.12.2. Knife

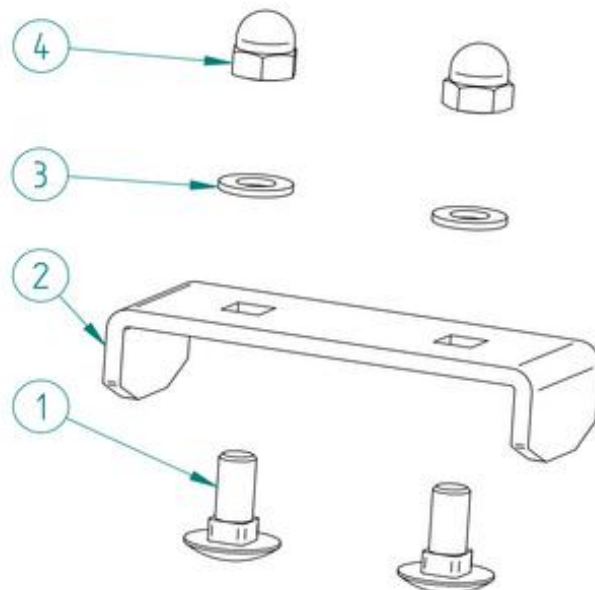

Item	Name	Index	Qty
1.	Carriage bolt M8x20-8.8		
		Katana-65	18
2.	Knife		
		Katana-65	9
3.	Washer M8		
		Katana-65	18
4.	Acorn nut M8		
		Katana-65	18

### 7.12.3. Bumper set

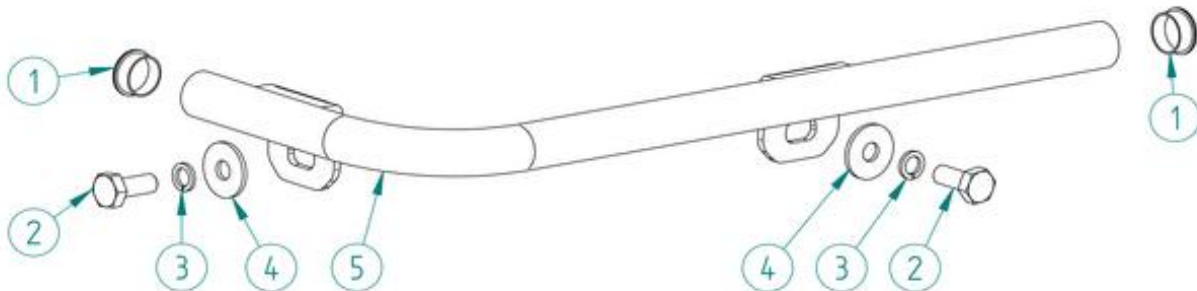

Item	Name	Index	Qty
1.	Cap ø25	FZ10166	2
2.	Bolt M10x25-8.8	BM101525	2
3.	Spring washer M10	LW10	2
4.	Extensional washer M10	LFW10	2
5.	Bumper		
		Katana-65	FZ10167

## **8. LIMITED WARRANTY**

Belco Resources Equipment warrants to the original purchaser of any new piece of machinery from Belco Resources Equipment, purchased from an authorized Belco Resources Equipment dealer, that the equipment be free from defects in material and workmanship for a period of one (1) year for non-commercial, state, and municipalities' use, ninety (90) days for commercial use from date of retail sale. Warranty for rental purposes is thirty (30) days. The obligation of Belco Resources Equipment to the purchaser under this warranty is limited to the repair or replacement of defective parts.

**Replacement or repair parts installed in the equipment covered by this limited warranty are warranted for ninety (90) days from the date of purchase of such part or to the expiration of the applicable new equipment warranty period, whichever occurs later. Warranted parts shall be provided at no cost to the user at an authorized Belco Resources Equipment dealer during regular working hours. Belco Resources Equipment reserves the right to inspect any equipment or parts, which are claimed to have been defective in material or workmanship.**

**This limited warranty does not apply to and excludes wear items such as shear pins, tires, tubes knives, blades or other wear items. Oil or grease is not covered by this warranty.**

**All obligations of Belco Resources Equipment under this limited warranty shall be terminated if:**

**Proper service is not performed on the machine.**

**The machine is modified or altered in any way.**

**The machine is being used or has been used for purposes other than those for which the machine was intended.**

## **DISCLAIMER OF IMPLIED WARRANTIES & CONSEQUENTIAL DAMAGES**

**Belco Resources Equipment obligation under this limited warranty, to the extent allowed by law, is in lieu of all warranties, implied or expressed, including implied warranties of merchantability and fitness for a particular purpose and any liability for incidental and consequential damages with respect to the sale or use of the items warranted. Such incidental and consequential damages shall include but not be limited to: transportation charges other than normal freight charges; cost of installation other than cost approved by Belco Resources Equipment; duty; taxes; charges for normal service or adjustment; loss of crops or any other loss of income; rental of substitute equipment, expenses due to loss, damage, detention or delay in the delivery.**

## **REGISTRATION**

**The online Warranty Registration must be completed in order to qualify for coverage on this Limited Warranty. Visit [br-equipment.com](http://br-equipment.com), click on "Warranty Registration" and completely fill out the form to register the new piece of equipment.**

**Page left blank intentionally**



Belco Resources Equipment  
401 Jeffrey's Road  
Rocky Mount, NC 27804  
Tel:(252) 822-7140  
Email:[sales@br-equipment.com](mailto:sales@br-equipment.com)  
[www.br-equipment.com](http://www.br-equipment.com)