

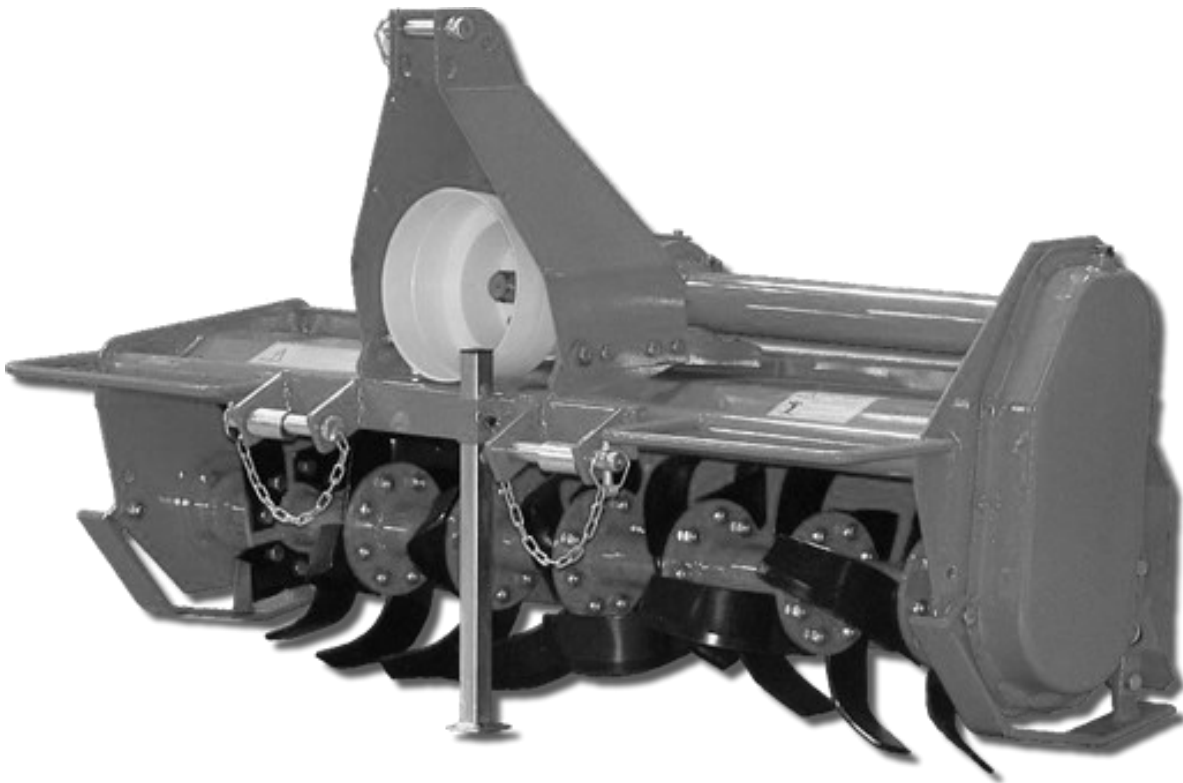

# Sub-Compact Rotary Tiller DLT & DLT-S Series



## Operator's Manual

**Page left blank intentionally**



**TO THE DEALER:**

Assembly and proper installation of this product is the responsibility of the Tar River dealer. Read manual instructions and safety rules. Make sure all items on the Dealer’s Pre-Delivery and Delivery Check Lists in the Owner’s/Operator’s Manual are completed before releasing equipment to the owner.

**TO THE OWNER:**

Read this manual before operating your Tar River equipment. The information presented will prepare you to do a better and safer job. Keep this manual handy for ready reference. Require all operators to read this manual carefully and become acquainted with all the adjustment and operating procedures before attempting to operate. Replacement manuals can be obtained from your selling dealer. The equipment you have purchased has been carefully engineered and manufactured to provide dependable and satisfactory use. Like all mechanical products, it will require cleaning and upkeep. Lubricate the unit as specified. Observe all safety information in this manual and safety decals on the equipment. For service, your authorized Tar River dealer has trained mechanics, genuine Tar River service parts, and the necessary tools and equipment to handle all your needs. Use only genuine Tar River service parts. Substitute parts will void the warranty and may not meet standards required for safe and satisfactory operation.

Record your implement model and serial number in the space provide below. Your dealer will need this information to give you prompt, efficient service.

**Model Number:** \_\_\_\_\_

**Serial Number:** \_\_\_\_\_

**Date Purchased:** \_\_\_\_\_

# Table of Contents

Introduction .....	5
Technical Specifications .....	5
Safety .....	6
Safety Signal Words .....	6
General Safety Guidelines .....	7
Safety Decal Care .....	7
Before Operation .....	8
During Operation .....	9
Highway And Transport Operations .....	10-11
Operating Instructions.....	12-14
Maintenance .....	14
Torque Specifications .....	15
Parts Breakdown .....	17-27
Decals.....	28-29
Warranty .....	30

## Introduction

Thank you for purchasing your DLT Series Rotary Tiller. Specifically designed and engineered for sub-compact tractors in the 15-25 Horse power range. The Tar River DLT Series Rotary Tiller is built with 4 blades per flange and a sturdy #80 chain drive system to give you years of reliable service. A Slip Clutch PTO protect comes standard.

Available in 42" and 50" working widths. The Tar River DLT Series Rotary Tiller is perfect for all your small-tractor tilling needs.

### Technical Specifications

- #80 Chain drive transmission
- 4 Blades per flange
- PTO with slip-clutch protection
- Solid A-frame
- Side shift standard

	<b>DLT-42</b>	<b>DLT-50</b>
Weight	304 lbs.	348 lbs.
Shipping weight	375 lbs.	429 lbs.
Working width	42"	50"
Blades per flange	4	4
Chain drive	#80	#80
HP	15-25	15-25
PTO driveline	Series 4 S/C	Series 4 S/C
Working width	55"	78"

# Important Safety Information

## Safety

It is important that you read the entire manual and to become familiar with this product before you begin using it. This product is designed for certain applications only. The manufacturer cannot be responsible for issues arising from modification. We strongly recommend this product not be modified and /or used for any application other than that for which it is designed. If you have any questions relative to a particular application, DO NOT use the product until you have first contacted us to determine if it can or should be performed on the product.

Read and understand this manual and all safety signs before operating and maintaining . Review the safety instructions and precautions annually.

## Safety Signal Words

**TAKE NOTE! This safety alert symbol found throughout this manual is used to call your attention to instructions involving your personal safety and the safety of others. Failure to follow these instructions can result in injury or death.**



**This symbol means:  
Attention!  
Become alert!  
Your safety is involved!**

Note the use of the signal words, DANGER, WARNING and CAUTION with the safety messages. The appropriate signal word for each has been selected using the following guidelines:



**DANGER:** Indicates an imminently hazardous situation that, if not avoided, will result in death or serious injury. This signal word is to be limited to the most extreme situations typically for machine components which, for functional purposes, cannot be guarded.



**WARNING:** Indicates a potentially hazardous situation that, if not avoided, could result in death or serious injury, and includes hazards that are exposed when guards are removed. It may also be used to alert against unsafe practices.



**CAUTION:** Indicates a potentially hazardous situation that, if not avoided, may result in minor or moderate injury. It may also be used to alert against unsafe practices.

# Important Safety Information

## General Safety Guidelines

Safety of the operator is one of the main concerns in designing and developing a new piece of equipment. Designers and manufacturers build in as many safety features as possible. However, every year many accidents occur which could have been avoided by a few seconds of thought and a more careful approach to handling equipment. You, the operator, can avoid many accidents by observing the following precautions in this section. To avoid personal injury, study the following precautions and insist those working with you, or for you, follow them.

Replace any DANGER, WARNING, CAUTION or instruction safety decal that is not readable or is missing. Location of such decals are indicated in this manual. Do not attempt to operate this equipment under the influence of drugs or alcohol.

Review the safety instructions with all users annually.

This equipment is dangerous to children and persons unfamiliar with its operation. The operator should be a responsible adult familiar with farm machinery and trained in this equipment's operations. **Do not allow persons to operate or assemble this unit until they have read this manual and have developed a thorough understanding of the safety precautions and of how it works.**

To prevent injury of death, use a tractor equipped with a Roll Over Protection System (ROPS). Do not paint over, remove or deface any signs or warning decals on your equipment. Observe all safety signs and practice the instructions on them.

Never exceed the limits of a piece of machinery. If its ability to do a job, or to do so safely, is in question - **Don't try it!**



## Safety Decal Care

- Keep safety signs clean and legible at all times.
- Replace safety signs that are missing or have become illegible.
- Replaced parts that displayed a safety sign should also display the current safety sign
- Safety signs are available from your Distributor or Dealer Parts Department or the factory.

## Important Safety Information

### How to install Safety Signs:

- Be sure that the installation area is clean and dry.
- Decide on the exact position before you remove the backing paper.
- Remove the smallest portion of the split backing paper.
- Align the decal over the specified area and carefully press the small portion with the exposed sticky backing in place.
- Slowly peel back the remaining paper and carefully smooth the remaining portion of the decal in place.
- Small air pockets can be pierced with a pin and smoothed out using the piece of decal backing paper.



### Before Operation

- Carefully study and understand this manual.
- Do not wear loose-fitting clothing, which may catch in moving parts.
- Always wear protective clothing and substantial shoes.
- Assure that all tires are inflated evenly.
- Give the unit a visual inspection for any loose bolts, worn parts or cracked welds, and make necessary repairs. Follow the maintenance safety instructions included with this manual.
- Be sure that there are no tools lying on or in the equipment.
- Do not use the unit until you are sure that the area is clear, especially of children and animals.
- Don't hurry the learning process or take the unit for granted. Ease into it and become familiar with your new equipment.
- Practice operation of your equipment and its attachments. Completely familiarize yourself and other operators with its operation before using.
- Use a tractor equipped with a Roll Over Protection System (ROPS) and fasten your seat belt prior to starting engine.
- The manufacturer does not recommend usage of tractor with ROPS removed.
- Move tractor wheels to the widest recommended settings to increase stability.
- Securely attach to towing unit. Use a high strength, appropriately sized hitch pin with a mechanical retainer and attach safety chain.
- Do not allow anyone to stand between the tongue or hitch and the towing vehicle when backing up to the equipment.
- Do not use the unit until you are sure that the area is clear, especially of children and animals.



## Important Safety Information



### During Operation

- Children should not be allowed on the product.
- Clear the area of small children and bystanders before moving the feeder.
- If using a towing unit, securely attach feeder by using a hardened 3/4" pin, a metal retainer, and safety chains if required. Shift towing unit to a lower gear before going down steep downgrades, thus using the engine as a retarding force. Keep towing vehicle in gear at all times. Slow down for corners and rough terrain.
- Make sure you are in compliance with all local and state regulations regarding transporting equipment on public roads and highways. Lights and slow moving signs must be clean and visible by overtaking or oncoming traffic when feeder is transported.
- Beware of bystanders, **particularly children!** Always look around to make sure that it is safe to start the engine of the towing vehicle or move the unit. This is particularly important with higher noise levels and quiet cabs, as you may not hear people shouting.
- **NO PASSENGERS ALLOWED!** Do not carry passengers anywhere on, or in, the tractor or equipment, except as required for operation.
- Keep hands and clothing clear of moving parts.
- Do not clean, lubricate or adjust your equipment while it is moving.
- When halting operation, even periodically, set the tractor or towing vehicle brakes, disengage the PTO, shut off the engine and **remove the ignition key.**
- Be especially observant of the operating area and terrain. Watch for holes, rocks or hidden hazards. Always inspect the area prior to operation.
- **DO NOT** operate near the edge of drop-offs or banks.
- **DO NOT** operate on steep slopes as overturns may result.
- Operate up and down (not across) intermediate slopes. Avoid sudden starts and stops.

## Important Safety Information



### Highway and Transport Operations

- Adopt safe driving practices.
- Keep the brake pedals latched together at all times. **Never use independent braking with machine in tow as loss of control and/or upset of unit can result.**
- Always drive at a safe speed relative to local conditions and ensure that your speed is low enough for an emergency stop to be safe and secure. Keep speed at a minimum.
- Reduce speed prior to turns to avoid the risk of overturning.
- Avoid sudden uphill turns on steep slopes.
- Always keep the tractor or towing vehicle in gear to provide engine braking when going downhill. Do not coast.
- Do not drink and drive!
- Comply with state and local laws governing highway safety and movement of farm machinery on public roads.
- Use approved accessory lighting flags and necessary warning devices to protect operators of other vehicles on the highway during daylight and nighttime transport. Various safety lights and devices are available from your dealer.
- The use of flashing amber lights is acceptable in most localities. However, some localities prohibit their use. Local laws should be checked for all highway and marking requirements.
- When driving the tractor and equipment on the road or highway under 40 kph (20 mph) at night or during the day, use the amber warning lights and a slow moving vehicle (SMV) identification emblem.
- Plan your route to avoid heavy traffic.
- Be a safe and courteous driver. Always yield to oncoming traffic in all situations, including narrow bridges, intersections, etc.
- Be observant of bridge loading ratings. Do not cross bridges rated at lower than the gross weight at which you are operating.
- Watch for obstructions overhead and to the side while transporting.
- Always operate in a position to provide maximum visibility at all times. Make allowances for increased length and weight of the equipment when making turns, stopping the unit, etc.
- Pick the most level route when transporting across fields. Avoid the edges of ditches or gullies and steep hillsides.
- Be extra careful when working in inclines.

## Important Safety Information



### Highway and Transport Operations

- Maneuver the tractor or towing vehicle at safe speeds.
- Avoid overhead wires or other obstacles. Contact with overhead lines could cause serious injury or death.
- Avoid loose fill, rocks and holes, they can be dangerous for equipment operation or movement.
- Allow for unit length when making turns,
- Operate the towing vehicle from the operator's seat only.
- Never stand alongside of unit with engine running or attempt to start engine and/or operate machine while standing alongside of unit.
- Never leave running equipment attachments unattended.
- As a precaution, always recheck the hardware on equipment following every 100 hours of operation. Correct all problems. Follow the maintenance safety procedures.

## Operating Instructions



Before attaching the rotary tiller to the tractor, check the unit to ensure there is oil in the top and side gearbox. See Maintenance section for lubricant specifications.

### Attaching the PTO shaft:

Before installing the PTO shaft make sure that the RPM rating and the direction of rotation match those of the tractor. Carefully read the PTO shaft and tractor instructions. Before operation, make sure that the guards are installed on the power take off of the tractor and PTO shaft. Make sure that they cover the PTO shaft throughout its length. Note: The PTO shaft may be too long and require shortening. See “Shortening a PTO driveline” below.

Press the locking pin on the PTO yoke and slide yoke on to the PTO of the tractor until the pin seats. Pull on PTO shaft to make certain it is locked in place. Repeat the procedure for the machine end. Attach the PTO cover’s safety chains to a stationary part of the tractor. Leave some slack in the chain to accommodate movement.

### Shortening a PTO driveline:

1. With the machine attached to the tractor’s 3-point hitch, and the PTO shaft not installed, separate the PTO shaft. Attach the machine end to the machine and the other end to the tractor PTO input shaft.
2. Raise the machine by using the tractor’s hydraulic 3-point hitch to its maximum lift height.
3. Hold the half shafts next to each other and mark them so each end is approximately 1/2” from hitting the end of the telescopic profiles.
4. Shorten the inner and outer guard tubes equally.
5. Shorten the inner and outer profiles by the same length as the guard tubes. Using a rattle file, round off all sharp edges and burrs. Grease the telescopic profile generously before reassembling.

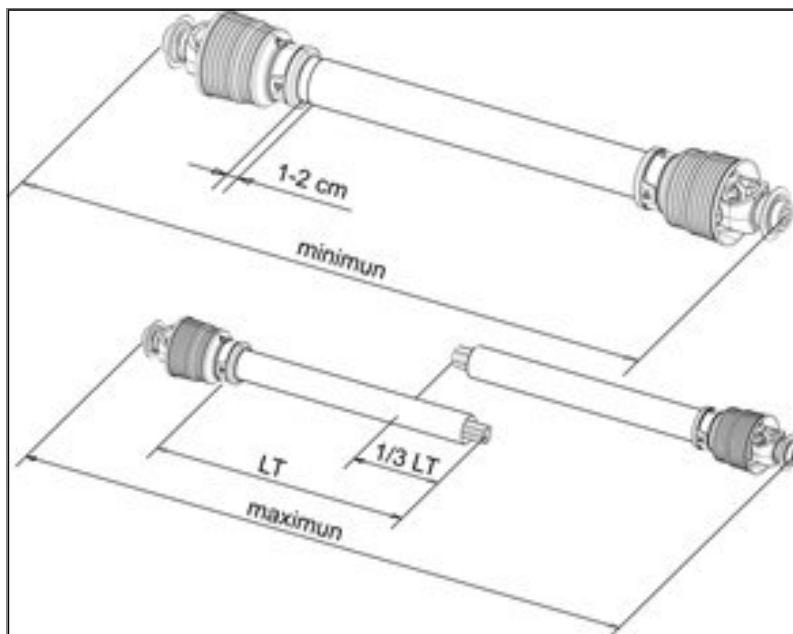

When fully extended, the tubes must overlap by at least 1/3 of the length of the pipes (LT). When retracted, the min. acceptable clearance is 1-2 cm (3/8”-3/4”)

Scan the QR code below for more detailed information on PTO installation.



## Operating Instructions

### Slip clutch adjustments

Slip clutch must be adjusted before first use or after a storage period.

1. Using a marker, scribe a line across the exposed edges of the clutch plate and friction discs.
2. Back off compression nuts to free friction discs by turning each nut *exactly* 2 revolutions.
3. Start the tractor and run the driveline at a low idle to slip the friction discs. This will remove the dirt, corrosion and surface floss from the clutch plate faces.
4. Disengage PTO, shut down tractor and wait for all components to come to a complete stop.
5. Inspect the clutch and ensure that the scribed markings on the disc and plates have changed position. If any two marks are still aligned, this is an indication that these discs have not slipped. It may be necessary to completely disassemble the clutch to free them up.
6. After ensuring all discs are free, tighten the compression nuts, uniformly, *exactly* 2 revolutions to reset the clutch original pressure.

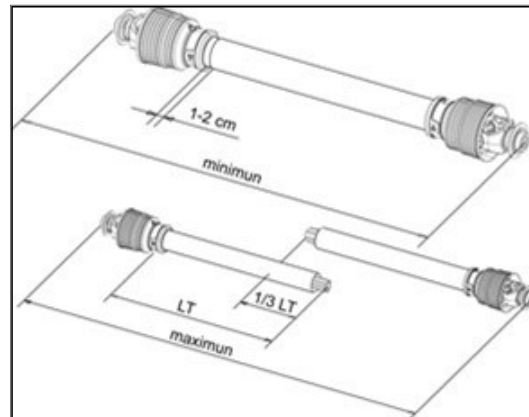

**Caution: Slip Clutches may become hot. Do Not Touch. Keep the slip clutch area clear of a material that may catch fire. Slip clutches have adjustable torque settings. The torque setting varies with the different compression of each spring. All the springs should have an equal amount of compression.**

**Important: Do not over-tighten the compression nuts as this may impair performance or cause premature wearing of the slip clutch.**

### Checking for PTO Driveline Interference:

1. Begin with the PTO Driveline level (0 degrees). Raise the implement at an angle no greater than 25 degrees from level. Check for any interference and the length of the PTO Driveline extended. Do not exceed the maximum extended length!
2. Next lower the PTO Driveline at an angle no greater than 25 degrees from level. Check for any interference and the length of the PTO Driveline extended. Do not exceed the maximum extended length!

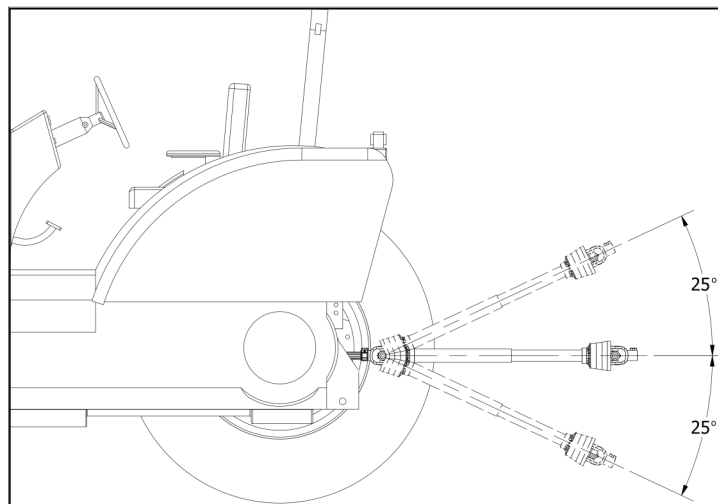

# Operating Instructions

## Working Depth Adjustment

The working depth is controlled by raising or lowering the side skids. If the skids are raised, the working depth increases. By lowering the skids, the tilling depth will decrease.

## Tailgate adjustment

The tailgate can be adjusted to help smooth and compact the tilled ground. Release the chain and secure to the desired height.



## Start up

After making the necessary adjustments, lower the rotary tiller until the blades are a couple of inches from the ground. Engage the PTO and slowly lower the tiller to begin working.

## Removal and Storage

1. After finishing, remove the rotary tiller from the tractor.
2. Put the PTO driveline in a safe location so it will not become damaged.
3. Clean and dry the equipment.
4. Replace any damaged or worn parts.
5. Check all bolts and nuts for tightness.
6. Lubricate and protect the machine from the elements.



### Following Operation

- Following operation, or when unhitching, stop the tractor or towing vehicle, set the brakes, disengage the PTO and all power drives, shut off the engine and **remove the ignition keys**.
- Store the unit in an area away from human activity.
- Do not park equipment where it will be exposed to livestock for long periods of time. Damage and livestock injury could result.
- Do not permit children to play on or around the stored unit.
- Make sure all parked machines are on a hard, level surface and engage all safety devices.
- Wheel chocks may be needed to prevent unit from rolling.

# Maintenance

- Good maintenance is your responsibility. Poor maintenance is an invitation to trouble.
- Make sure there is plenty of ventilation. Never operate the engine of the towing vehicle in a closed building. The exhaust fumes may cause asphyxiation.
- Be certain all moving parts on attachments have come to a complete stop before attempting to perform maintenance.
- Always use the proper tools or equipment for the job at hand.
- Use extreme caution when making adjustments.
- Never replace hex bolts with less than grade five bolts unless otherwise specified.
- After servicing, be sure all tools, parts and service equipment are removed.
- Where replacement parts are necessary for periodic maintenance and servicing, genuine factory replacement parts must be used to restore your equipment to original specifications. The manufacturer will not claim responsibility for use of unapproved parts and/or accessories and other damages as a result of their use.
- If equipment has been altered in any way from original design, the manufacturer does not accept any liability for injury or warranty.

## Maintenance Schedule

<b>8 hours</b>	Grease the Rotor support ( <b>GP grease</b> )
	Grease PTO shaft cross & bearings ( <b>GP grease</b> )
	Check Hardware for tightness
<b>16 hours</b>	Check oil level in center gearbox ( <b>90wt</b> )
	Check oil level in side gearbox ( <b>140wt</b> )
	Check Hardware for tightness
<b>200 hours</b>	Replace oil in center gearbox ( <b>90wt</b> )
	Replace oil in side gearbox ( <b>140wt</b> )
	Change chain tensioner spring ( <b>DLT model only</b> )
	Check Hardware for tightness

## Replacing Blades

In order for the tiller to perform optimally, make sure the tiller blades are in good working condition and their bolts and nuts tight. Always replace the blades with the bolt head against the blade and the washer and nut on the flange side to help prevent the blades from loosening.

When several blades are to be replaced, replace them one blade at a time in order maintain the scroll pattern on the rotor.

# Maintenance

## Lubrication

### Side Gearbox:

- Run the tiller long enough to warm the oil.
- Level the tiller, shut off tractor and set the park brake. Remove the “Lower Plug”. The warmed lubricant should reach the bottom of the “Lower Plug” hole as shown.
- If the lubricant level is below the bottom of the “Lower Plug” hole, add oil through the “Fill Plug” hole or “Lower Plug” hole. Add SAE 140W oil to bring the level to the normal operating range.
- Replace and tighten all plugs before operating the tiller.

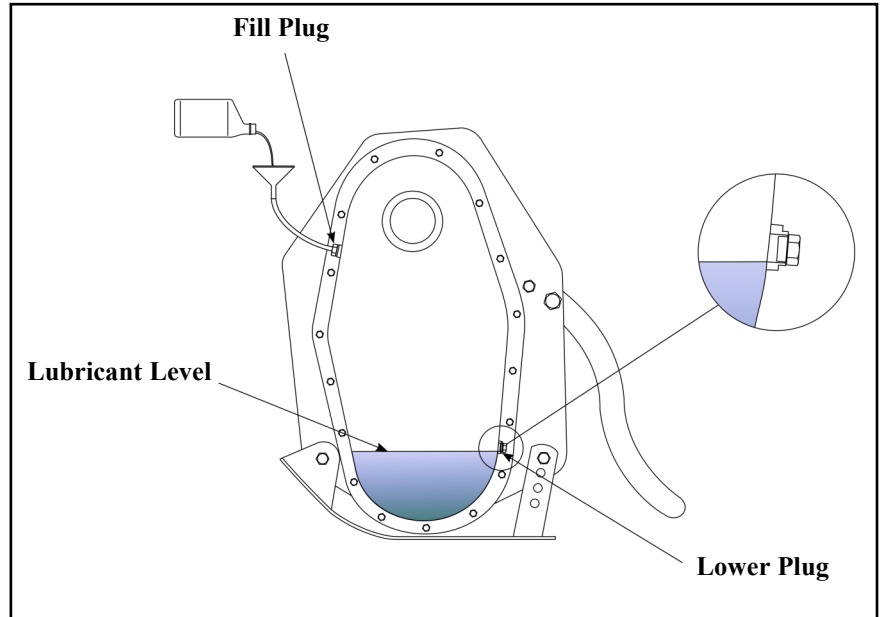

**Note: Check after 16 hours of use.**

### Center Gear Box:

- Unscrew and remove the dipstick and wipe clean.
- Screw in dipstick and hand tighten only.
- Once again, remove the dipstick and check the oil level. If the oil level is on or below the low level mark, add enough oil (SAE 80-90W oil) to the gearbox to bring the oil level up to normal operating range between the low mark and high mark.
- Screw in dipstick before operating the tiller.
- Do not overfill.

**Note: Check after 16 hours of use.**

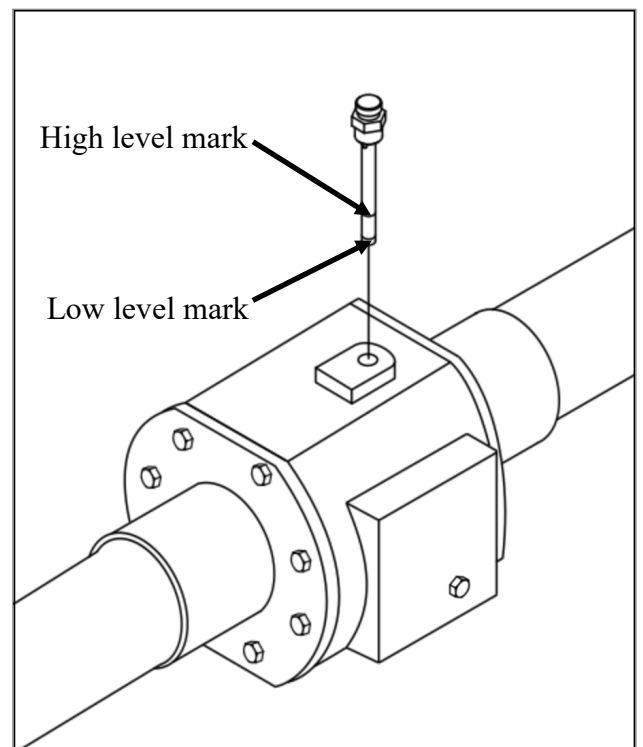



# Maintenance

## Lubrication

### Gearbox Input Shaft:

- When attaching and reattaching the PTO driveline, be sure to lubricate all surfaces of the gearbox input shaft with Multi-Purpose Grease.

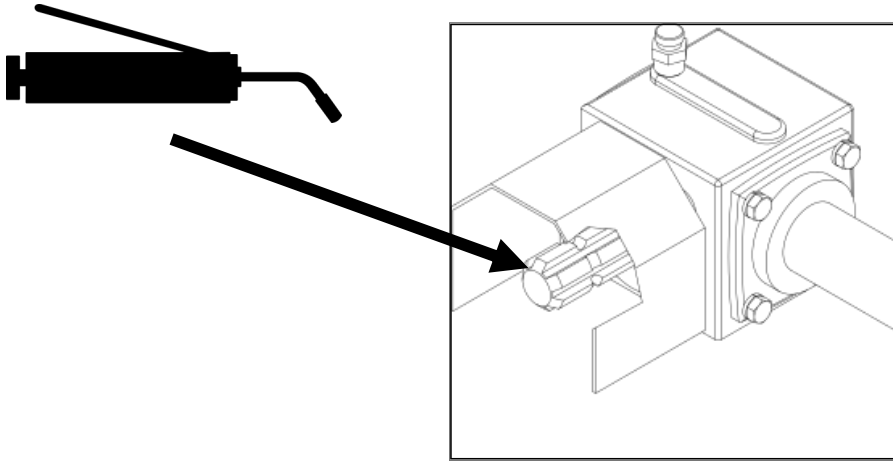

### PTO Driveline:

- Grease the PTO Driveline U-joints with Multi-Purpose Grease every 8 hours of use.
- Slide apart the two PTO Driveline halves from each other. Clean and coat (every 20 hours of use) the inner tube of the PTO Driveline shaft with a thin layer of Multi-Purpose Grease and reassemble.

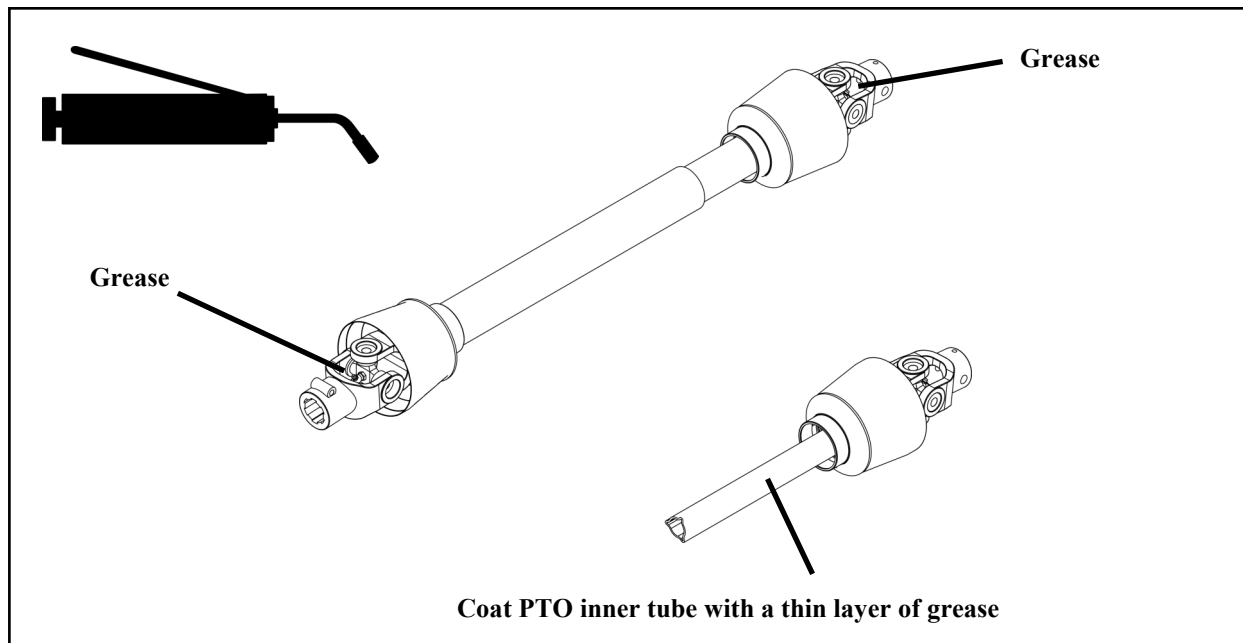

# Maintenance

## Lubrication

### **Rotor Support:**

Lubricate the grease fitting on the RH end of the Rotor Shaft, with Multi-Purpose Grease every 8 hours of use.

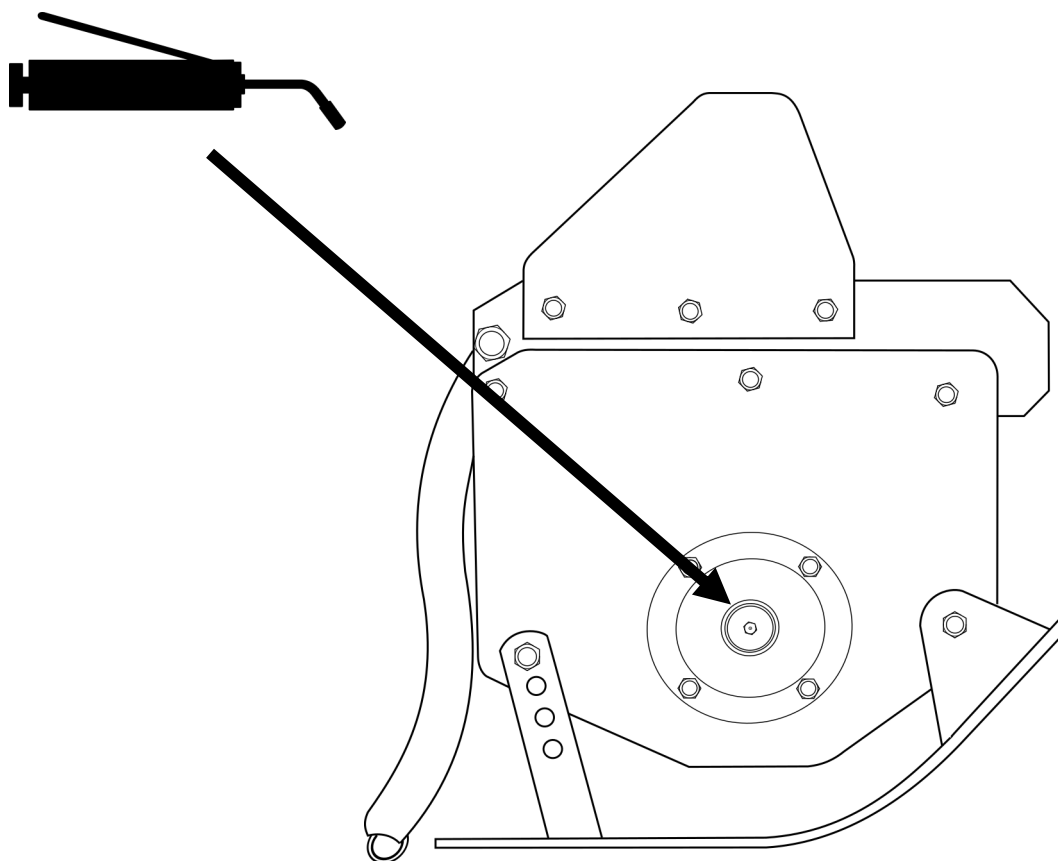

# Torque Specifications

Torque Specifications for Common Bolt Sizes															
Inches		Bolt Head Identification						Metric		Bolt Head Identification					
										5.8		8.8		10.9	
Bolt size (inches)	Thread pitch	Grade 2		Grade 5		Grade 8		Class 5.8		Class 8.8		Class 10.9			
		N.m	ft-lb	N.m	ft-lb	N.m	ft-lb	N.m	ft-lb	N.m	ft-lb	N.m	ft-lb		
1/4"	20	7	5	11	8	16	12	M5	0.08	4	3	6	4	9	7
1/4"	28	8	6	13	10	19	14	M6	1	6	4	10	7	15	11
5/16"	18	15	11	24	17	33	25	M8	1.25	16	12	25	18	36	27
5/16"	24	17	13	26	19	37	27	M8	1	17	13	26	19	38	28
3/8"	16	27	20	42	31	59	44	M10	1.5	31	23	48	35	71	52
3/8"	24	31	23	47	35	67	49	M10	1.25	33	24	51	38	75	55
7/16"	14	43	32	67	49	95	70	M10	1	35	26	53	39	78	58
7/16"	20	48	36	75	55	106	78	M12	1.75	54	40	84	62	123	91
1/2"	13	66	48	102	75	144	106	M12	1.5	56	41	87	64	128	94
1/2"	20	75	55	115	85	163	120	M12	1.25	59	44	90	66	133	98
9/16"	12	95	70	147	109	208	154	M14	2	84	62	133	98	195	144
9/16"	18	106	79	164	121	232	171	M14	1.5	94	69	142	105	209	154
5/8"	11	132	97	203	150	287	212	M16	2	131	97	206	152	302	223
5/8"	18	149	110	230	170	325	240	M16	1.5	141	104	218	161	320	236
3/4"	10	233	172	361	266	509	376	M18	2.5	181	133	295	218	421	310
3/4"	16	261	192	403	297	569	420	M18	2	196	145	311	229	443	327
7/8"	9	226	167	582	430	822	606	M18	1.5	203	150	327	241	465	343
7/8"	14	249	184	642	473	906	668	M20	2.5	256	189	415	306	592	437
1"	8	339	250	873	644	1232	909	M20	1.5	288	212	454	335	646	476
1"	12	371	273	955	704	1348	995	M22	2.5	344	254	567	418	807	595
1-1/8"	7	480	354	1077	794	1746	1288	M22	1.5	381	281	613	452	873	644
1-1/8"	12	539	397	1208	891	1958	1445	M24	3	444	327	714	526	1017	750
1-1/4"	7	677	500	1519	1120	2463	1817	M24	2	488	360	769	567	1095	808
1-1/4"	12	750	553	1682	1241	2728	2012	M27	3	656	484	1050	774	1496	1103
1-3/8"	6	888	655	1992	1469	3230	2382	M27	2	719	530	1119	825	1594	1176
1-3/8"	12	1011	746	2268	1673	3677	2712	M30	3.5	906	668	1420	1047	2033	1499
1-1/2"	6	1179	869	2643	1949	4286	3161	M30	2	1000	738	1600	1180	2250	1659
1-1/2"	12	1326	978	2974	2194	4823	3557	M36	4	1534	1131	2482	1830	3535	2607

**Notes:**

This chart is an approximate estimate of torque values.

Always tighten hardware to these values unless a different torque value or tightening procedure is listed for a specific application.

Fasteners must always be replaced with the same grade as specified in the manual.

Always use the proper tool for tightening hardware: SAE for SAE hardware and Metric for Metric hardware.

Make sure that fastener threads are clean and that you properly start thread engagement.

**Page left blank intentionally**



# Sub-Compact Rotary Tiller DLT & DLT-S Series

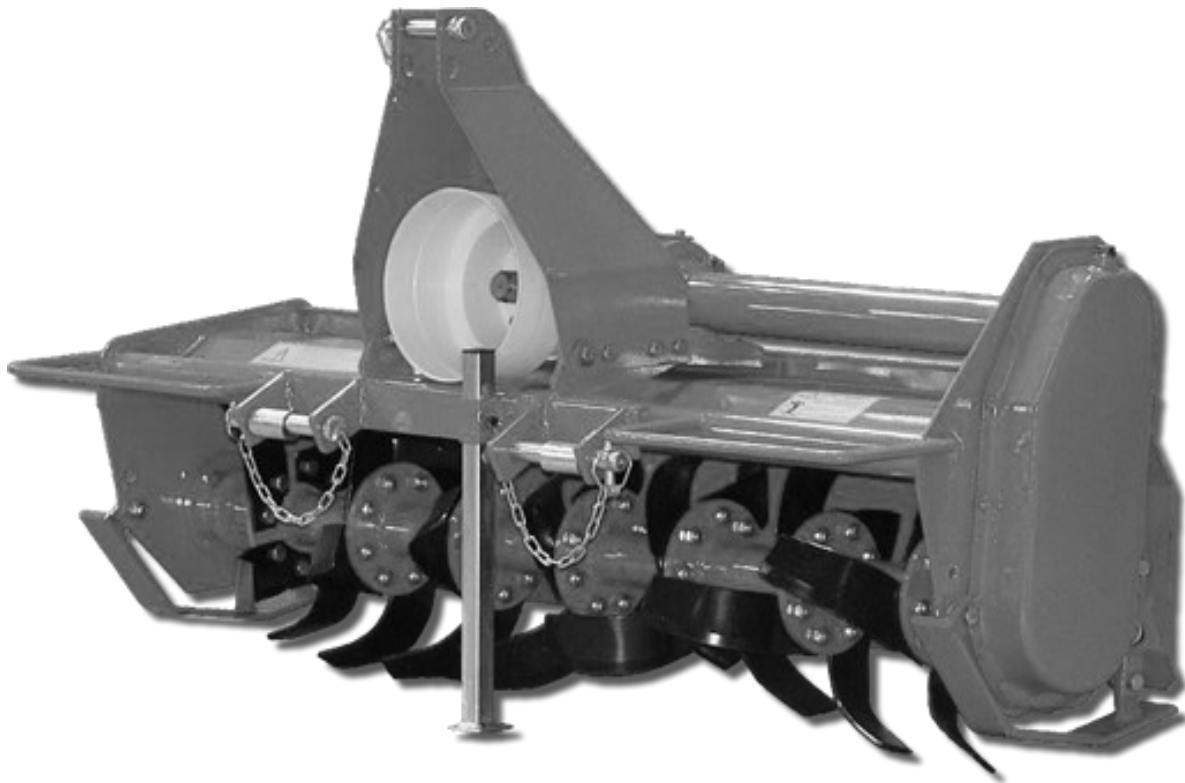

## Parts Manual

# DLT Series Rotary Tiller

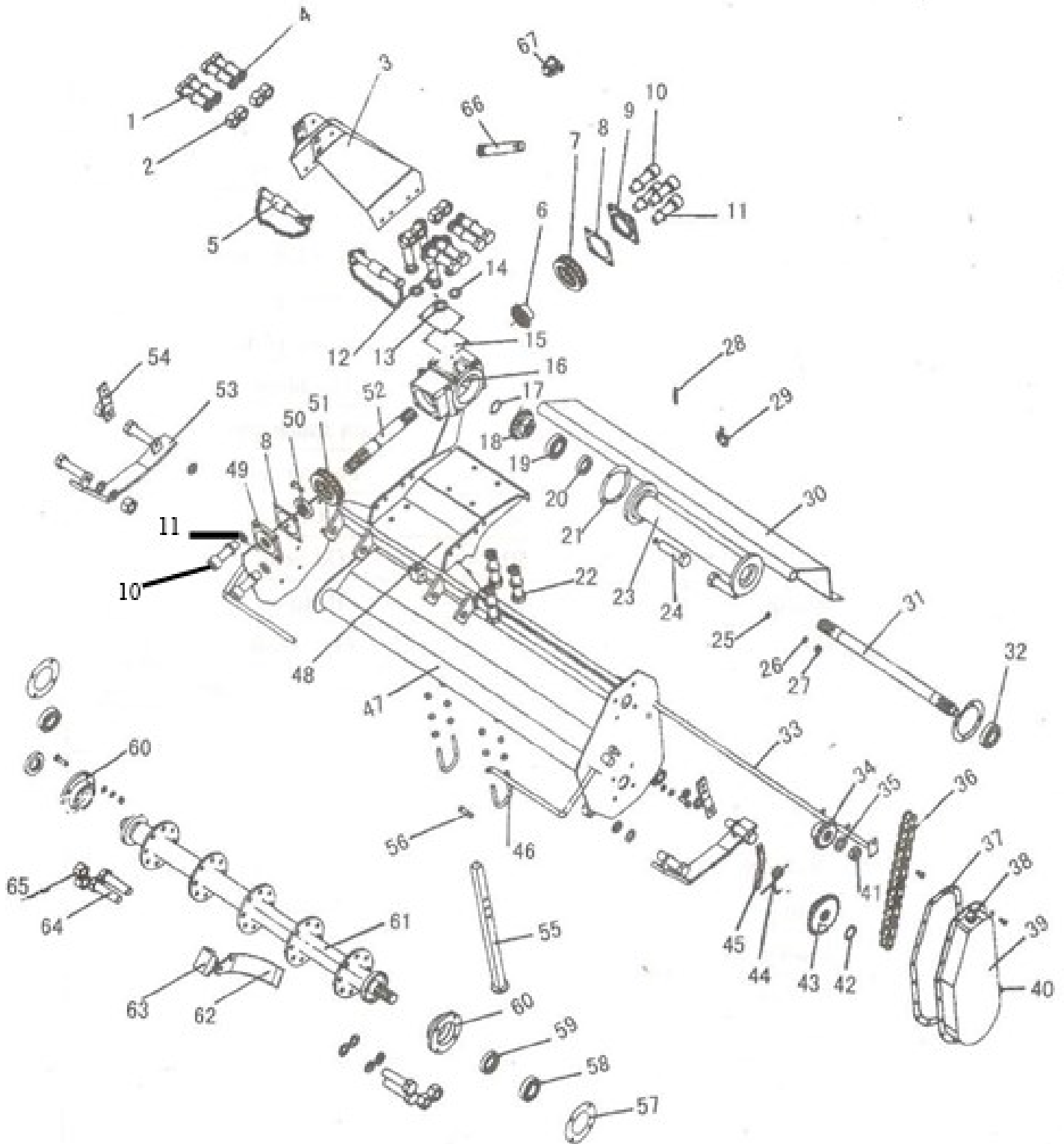

## DLT Series Rotary Tiller

Item	Part #	Description	Qty.
1	BM101530	Bolt - M10 x 1.5 x 30	8
2	NM1015	Nut - M10 x 1.5	8
3	DP1003	A Frame	1
4	LW10	Lock Washer - M10	8
5	DP1005	Lower Suspension Pin	2
6	DP1006	Small Bevel Gear	1
7	B30207	Bearing 30207	1
8	DP1008	Gasket - Dia. 80	2
9	DP1009	Cap - Dia. 80	1
10	ABM101525	Bolt - M10 x 1.5 x 25	8
11	LW10	Lock Washer - M10	8
12	BM061016	Bolt - M6 x 1.0 x 16	4
13	DP1013	Cap	1
14	LW06	Lock Washer - M6	4
15	DP1015	Gasket	1
16	DP1016	Intermediate Gearbox	1
17	SRE-35	Snap Ring - External - M35	1
18	DP1018	Big Bevel Gear	1
19	B30207	Bearing - 30207	1
20	OS355512	Oil Seal - M35 x 55 x 12	1
21	DP1021	Gasket - Dia. 90	2
22	BM101525	Bolt - M10 x 1.5 x 25	4
23	DP1023	Main Frame Pipe - DLT042	1
23	DP10231	Main Frame Pipe - DLT050	1
24	ABM101530	Allen Head Bolt - M10 x 1.5 x 30	8
25	FW10	Flat Washer - M10	8
26	LW10	Lock Washer - M10	8
27	LNLM10	Self-locking Nut - M10 x 1.5	8
28	DP1028	Tailgate Chain	1
29	DP1029	Hook	1
30	DP1030	Tail Gate - DLT042	1
30	DP10301	Tail Gate - DLT050	1
31	DP1031	Output Shaft - DLT042	1
	DP10311	Output Shaft - DLT050	1
32	B6011	Bearing 6011	2
33	DP1033	Rod- DLT042	1
33	DP10331	Rod- DLT050	1
34	DP1034	Small Sprocket Wheel	1
35	SW24	Stop Washer	1

# DLT Series Rotary Tiller

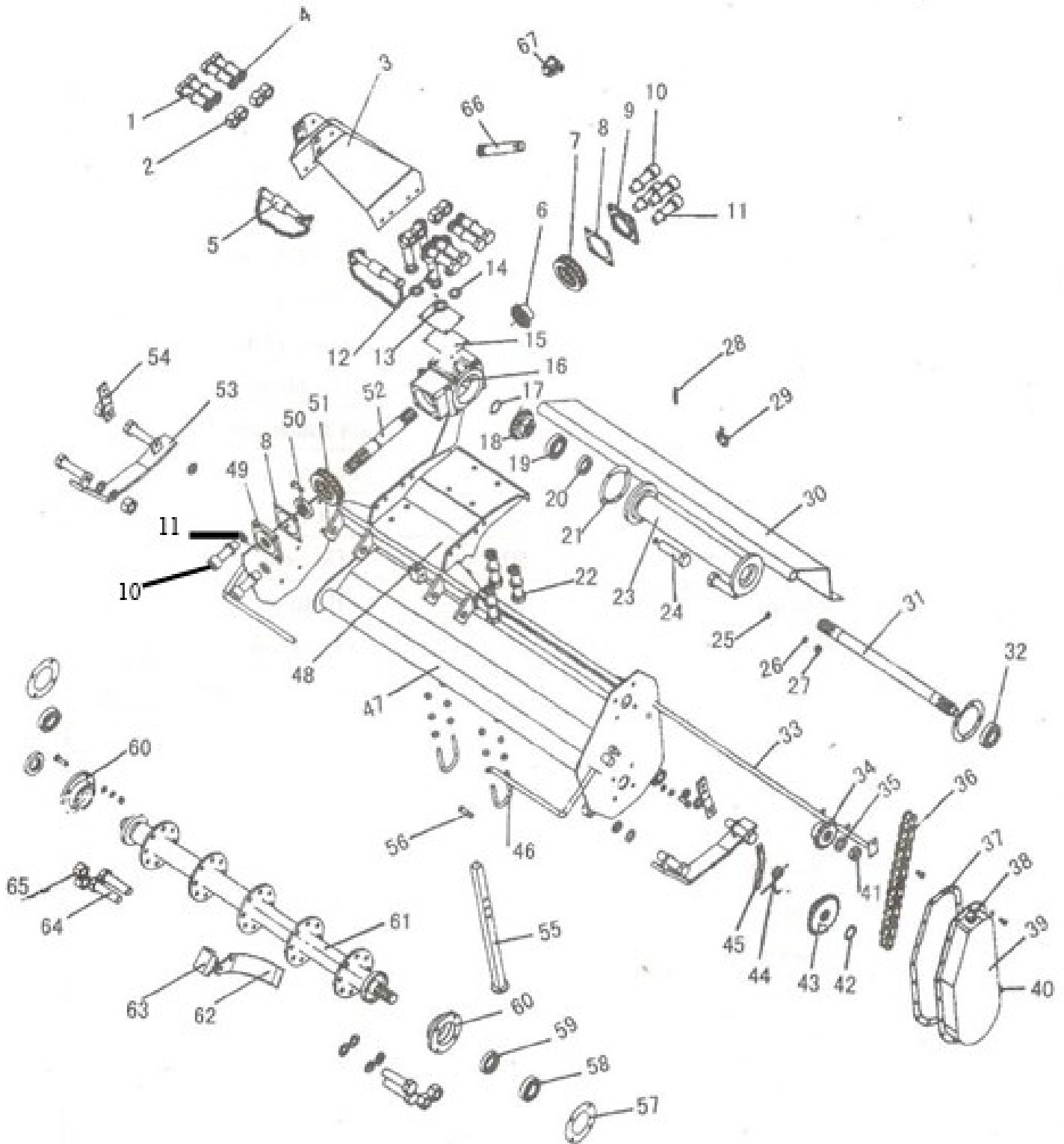



## DLT Series Rotary Tiller

Item	Part #	Description	Qty.
36	DP1036	Drive Chain-12A	1
37	DP1037	Oil Seal Gasket	1
38	OP1615B	Oil Filler Plug (Breather)- M16 x 1.5	1
39	DP1039	Side Chain Gear Box	1
40	OP1615	Oil Drain Plug- M16 x 1.5	1
41	SNM2415	Spanner Nut- M24 x 1.5	1
42	SRE-32	Spanner Nut- M24 x 1.5	1
43	DP1043	M32Big Sprocket Wheel	1
44	DP1044	Spring	1
45	DP1045	Tension Arm	1
46	DP1046	U-Bolt- M12 x 1.75	1
47	DP1047	Main Frame	1
48	DP1048	Gearbox Support	1
49	DP1049	Cap	1
50	OS356512	Oil Seal M35 x 65 x 12	1
51	B6011	Bearing 6011	1
52	DP1052	Input Shaft	1
53	DP1053	Skid	1
54	DP1054	Skid Connection	1
55	DP1055	Stand Bar	1
56	DP1056	Pin	1
57	DP1057	Oil Seal Gasket	1
58	B6207	Bearing- 6207	1
59	OS406512	Oil Seal- M40 x 65 x 12	1
60	DP1060	Bearing Seat	1
61	DP1061	Blade Rotor- DLT042	1
61	DP10611	Blade Rotor- DLT050	1
62	DP1062	Left- Blade	12, 14
63	DP1063	Right- Blade	12, 14
64	BM1217530	Bolt- M12 x 1.75 x 30	48, 56
65	LN12175	Self-locking Nut- M12 x 1.75	48, 56
66	DP1066	Upper Suspension Pin	1
67	DP1067	Spring Lock Pin	1
-	DP1069	Gearbox complete	1

# DLT-S Series Rotary Tiller

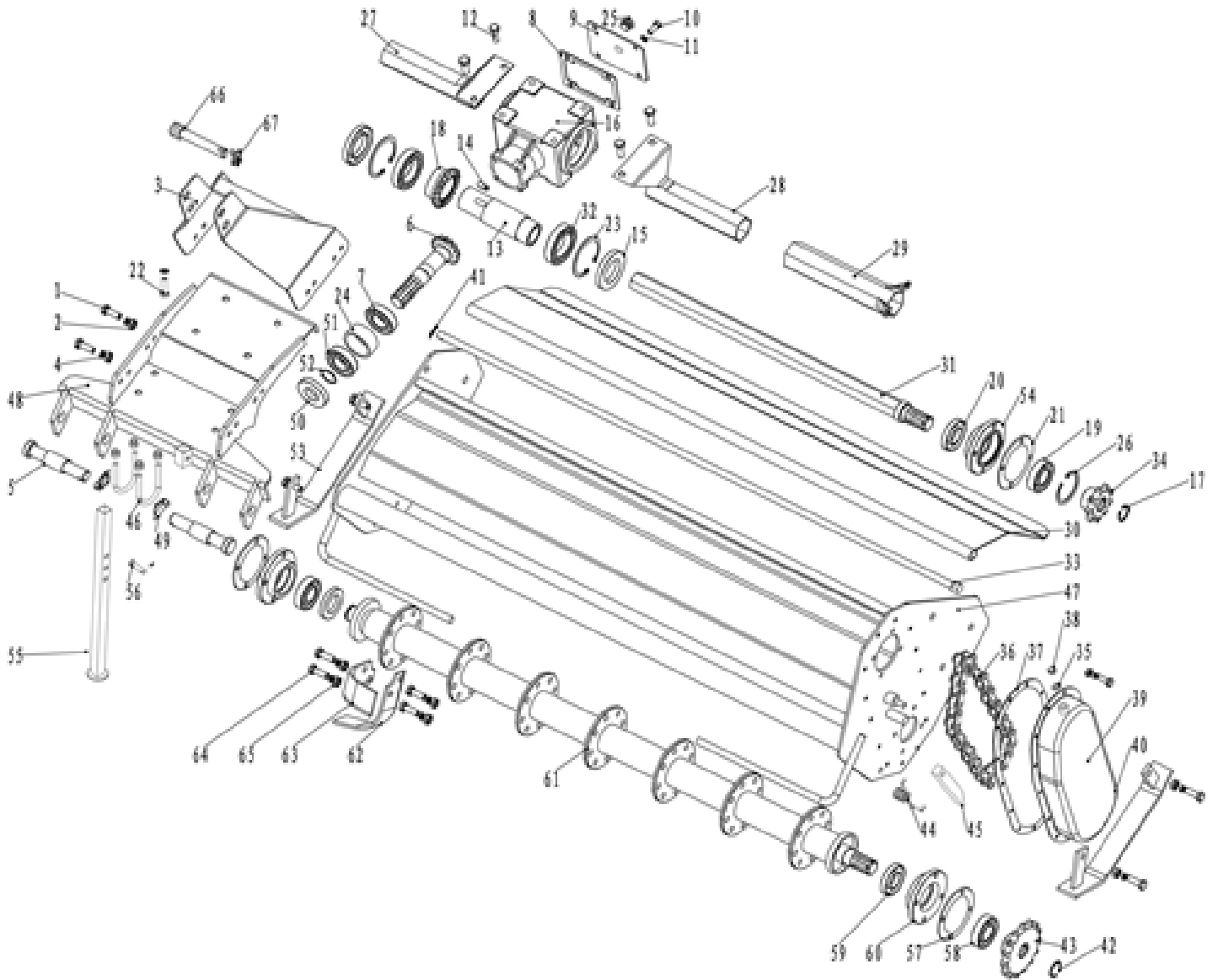

## DLT-S Series Rotary Tiller

Item	Part #	Description	Qty.
1	BM101530	Bolt- M10 x 1.5 x 30	8
2	NM1015	Nut- M10 x 1.5	8
3	DP1003	A-Frame	1
4	LW10	Lock Washer- M10	8
5	DP1005	Lower Suspension Pin	2
6	DP2006	Input shaft	1
7	B32010	Bearing- 32010	1
8	DP2008	Gasket- Rear Cover	2
9	DP2009	Rear Cover- Gearbox	1
10	BM1012525	Bolt- M10 x 1.25 x 25	8
11	LW10	Lock Washer- M10	8
12	BM061525	Bolt- M12 X 1.5 X 25	4
13	DP2013	Hex coupler	1
14	KM120830	Key- M12 x 8 x 30	4
15	OS559012	Oil Seal- M55 x 90 x 12	2
16	DP2016	Gearbox Housing	1
17	SRE-32	Snap Ring- External- M32	1
18	DP2018	Bevel Gear	1
19	B6207	Bearing- 6207	1
20	OS456512	Oil Seal- M45 x 65 x 12	1
21	DP2021	Gasket	2
22	BM1012525	Bolt- M10 x 1.25 x 25	4
23	SRE-90	Snap Ring- External- M90	2
24	DP2025	Bushing- Gearbox	1
25	DP2026	Gearbox Plug	1
26	SRI-72	Snap Ring- Internal- M72	1
27	DP2027	Shield- Right	1
28	DP2028	Shield- Left inner	1
29	DP2029	Shield- Left Outer	1
30	DP2030-42	Tail Gate- (DLT-S42)	1
30	DP2030-50	Tail Gate- (DLT-S50)	1
31	DP2031-42	Hex Shaft- (DLT-S42)	1
31	DP2031-50	Hex Shaft- (DLT-S50)	1
32	B30207	Bearing- 30207	1
33	DP1033	Tailgate Rod- (DLT-S42)	1
33	DP10331	Tailgate Rod- (DLT-S50)	1
34	DP1034	Sprocket Upper	1
35	SW24	Stop Washer	1
36	DP1036	Drive Chain- 12A	1

# DLT-S Series Rotary Tiller

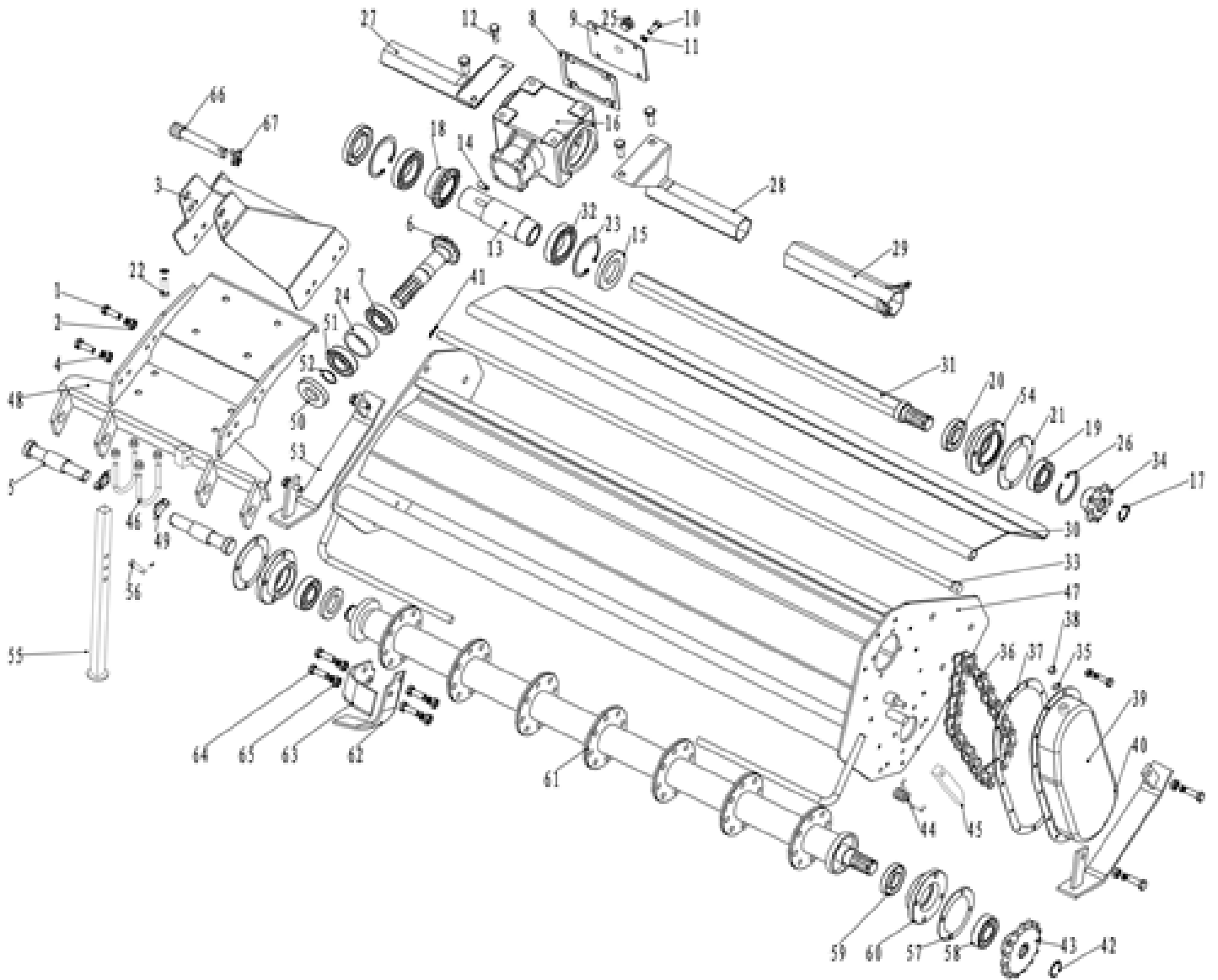

## DLT-S Series Rotary Tiller

Item	Part #	Description	Qty.
37	DP1037	Side Gearbox Cover Gasket	1
38	OP1615B	Oil Filler Plug (Breather)- M16 x 1.5	1
39	DP1039	Side Chain Gear Box	1
40	OP1615	Oil Drain Plug- M16 x 1.5	1
41	-		1
42	SRE-35	Snap Ring- External- M35	1
43	DP1043	Sprocket- Bottom	1
44	DP1044	Spring	1
45	DP1045	Tension Plate	1
46	DP1046	U-Bolt- M12 x 1.75	2
47	DP1047	Main Frame- (DLT-S42)	1
-	DP10471	Main Frame- (DLT-S40)	1
48	DP2048	Support- Gearbox DLT "S" Series	1
49	DP1067	Lynch Pin	2
50	OS357212	Oil Seal- M35 x 72 x 12	1
51	B30307	Bearing- 30307	4
52	SRE-35	Snap Ring- External- M35	1
53	DP1053	Skid Shoe	2
54	DP1054	Bearing Support	1
55	DP1055	Stand	1
56	DP1056	Stand Pin (includes washer and R-Clip)	1
57	DP1057	Gasket	2
58	B6207	Bearing- 6207	2
59	OS406512	Oil Seal- M40 x 65 x 12	2
60	DP1060	Bearing Support for Rotor	2
61	DP1061	Rotor Shaft (DLT-S42)	1
	DP10611	Rotor Shaft (DLT-S50)	1
62	DP1062	Left- Blade	12,14
63	DP1063	Right- Blade	12,14
64	BM1217530	Bolt for Tiller Blade- M12 x 1.75 x 30	48, 56
65	LNM12175	Lock Nut for Tiller Blade- M12 x 1.75	48, 56
66	DP1066	Upper Hitch Pin	1
67	DP1067	Lynch Pin	1
68	-		
69	LW12	Lock Washer- M12	48, 56
-	DP2069	Gearbox complete	1

# PTO Shaft

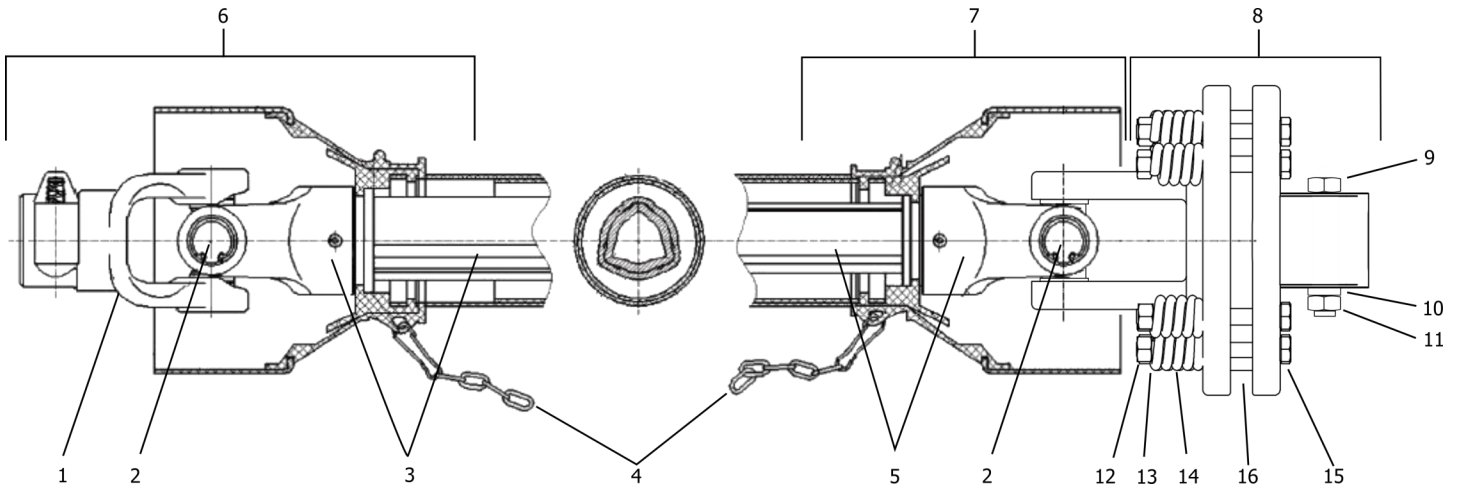

## PTO Shaft

Item	Part #	Description	Qty.
1	DP1075-40	PTO Yoke - Series 40	1
2	DP1076-40	Cross and Bearings - Series 40	2
3	DP1079-40	Female Yoke and Tube (tractor end) - Series 40	1
4	5SB3007	Safety chain	2
5	DP1078-40	Male Yoke and Tube (implement end) - Series 40	1
6	DP1074F-30	Complete Female End PTO Shielding (tractor end)	1
7	DP1074M-30	Complete Male End PTO Shielding (implement end)	1
8	DP1098-30	Slip clutch complete 150mm clutch	1
9	BM1217565	Bolt HH M12-1.75x65 (8.8)	1
10	LNLM12175	Nut lock M12-1.75	1
11	FW12	Washer flat M12	1
12	LNLM1015	Nut lock M10-1.50	8
13	FW10	Washer flat M10	8
14	1215012-30	Spring - slip clutch	8
15	BM101585	Bolt HH 10-1.50x85	8
16	180-510-30	Friction disc - 4-3/4" OD	2
-	147120	Complete PTO - Series 40 - 150mm Slip Clutch	1

# Decals

**⚠ WARNING**

**To prevent serious injury or death:**  
 si no lee ingles, pida ayuda a alguien que si lo lea para que le traduzca las medidas de seguridad

- Read and understand Operator's Manual before using. Review annually.
- Do not permit riders on the tractor including children.
- Do not allow children to operate unit.
- Operate only with guards installed and in good working condition.
- Keep away from moving parts.
- Operate only with tractor equipped with ROPS and seatbelts.
- Use extra care when operating on rough terrain or when rocks or debris are present.
- Do not operate in a raised position.
- Stop engine, lower unit, set brake and wait for all moving parts to stop before dismounting.
- Support unit securely before working beneath it.
- Transport with clean reflectors, SMV and working lights as required by Federal, State and local laws.
- Keep yourself, others and clothing away from rotating PTO.
- Operate only at a safe distance from bystanders.
- Do not stand between tractor and unit.
- Be careful on uneven terrain. Decrease speed when turning.
- Locate underground utility lines before operating unit.
- Do not exceed a safe transport speed.

RT1004D

1

**⚠ DANGER**

**ROTATING DRIVELINE HAZARD  
KEEP AWAY**

To prevent serious injury or death from rotating driveline:

- Keep all guards in place when operating.
- Operate only at 540 RPM.
- Keep hands, feet, clothing and hair away from moving parts.
- Do not operate without driveline securely attached at both ends.
- Do not operate without driveline shield that turns freely on driveline.

RT1007

5

**⚠ WARNING**

**Cancer and Reproductive Harm**  
[www.P65Warnings.ca.gov](http://www.P65Warnings.ca.gov) D960

2

**⚠ WARNING**

**TO PREVENT SERIOUS INJURY OR DEATH**

- Keep hands and body out of hitch area when attaching mower to tractor.
- Keep body clear of crush point between tractor and mower.

RT1005

3

**⚠ DANGER**

**ROTATING TINES HAZARD**

- Keep away from rotating tines.
- Rotating tines may cause serious injury or death.

RT1006

4

**⚠ DANGER**

**FAILING TO FOLLOW SAFETY MESSAGES AND OPERATING INSTRUCTIONS CAN CAUSE SERIOUS BODILY INJURY OR EVEN DEATH TO OPERATOR AND OTHERS IN THE AREA.**

<p>1. READ MANUAL.</p>	<p>2. SEAT BELTS, ROPS, NO RIDERS!</p>	<p>3. SAFETY SHOES, HARD HAT, SAFETY GLASSES.</p>	<p>4. SUPPORT MACHINE TO AVOID CRUSHING.</p>
------------------------	--	---	--

1. Read operator's manual carefully and pay attention to safety decals for tractor and tiller thoroughly to avoid misuse, abuse and accidents. Practice before operating.
2. Operate only with ROPS and fastened seat belt to avoid injury and possible crushing death from overturning. Do not allow riders on tractor or tiller. Falling off can cause serious injury or death by being run over by tractor or tiller or by being cut by the rotating tiller blades. Do not allow children on or near tiller or tractor.
3. To avoid injury from falling objects wear hard hat, safety glasses and shoes.
4. Block up or support machine securely before putting hands or feet under, or working underneath lifted parts to avoid crushing injury or even death from sudden, inadvertent dropping. Make sure area is clear before lowering.
5. Before transporting, put lift lever in Lift (Detent) position and follow all traffic codes. Slow down at night, in turns and on hillsides.
6. Make sure that SMV sign, warning lights and reflectors are clearly visible.
7. Never operate with tiller raised off ground to reduce possibility of injury from objects thrown under tiller structure.
8. Before dismounting, secure tiller in transport position or lower to ground, stop PTO, put tractor in park or set brake, stop engine and remove key. Never mount or dismount moving vehicle to prevent possible crushing injury or death.

<p>5. TRANSPORT SAFELY.</p>	<p>6. USE SMV, LIGHTS &amp; REFLECTORS.</p>	<p>7. DO NOT OPERATE WITH TILLER RAISED.</p>	<p>8. MOUNTING &amp; DISMOUNTING VEHICLE.</p>
-----------------------------	---	--	---

RT1008

6





## Decals

Item	Part #	Description	Qty.
1	RT1004E	Decal Warning “Serious Injury or Death”	1
2	D960	Decal Warning “Cancer & Reproductive Harm”	1
3	RT1005	Decal Warning “To Prevent Serious Injury”	1
4	RT1006	Decal Danger “Rotating Tines Hazard”	1
5	RT1007	Decal Danger “Rotating Driveline Hazard”	1
6	RT1008	Decal Danger “Failing to Follow Safety Messages”	1
7	D1015	Decal Logo “Tar River” Small	1
8	NA	Decal Model # “DLT-XXX”	1

# Warranty

## LIMITED WARRANTY

Belco Resources Equipment warrants to the original purchaser of any new piece of machinery from Belco Resources Equipment, purchased from an authorized Belco Resources Equipment dealer, that the equipment be free from defects in material and workmanship for a period of one (1) year for non-commercial, state, and municipalities' use, ninety (90) days for commercial use from date of retail sale. Warranty for rental purposes is thirty (30) days. The obligation of Belco Resources Equipment to the purchaser under this warranty is limited to the repair or replacement of defective parts.

Replacement or repair parts installed in the equipment covered by this limited warranty are warranted for ninety (90) days from the date of purchase of such part or to the expiration of the applicable new equipment warranty period, whichever occurs later. Warranted parts shall be provided at no cost to the user at an authorized Belco Resources Equipment dealer during regular working hours. Belco Resources Equipment reserves the right to inspect any equipment or parts, which are claimed to have been defective in material or workmanship.

This limited warranty does not apply to and excludes wear items such as shear pins, tires, tubes knives, blades or other wear items. Oil or grease is not covered by this warranty.

All obligations of Belco Resources Equipment under this limited warranty shall be terminated if:

- Proper service is not performed on the machine.

- The machine is modified or altered in any way.

- The machine is being used or has been used for purposes other than those for which the machine was intended.

## DISCLAIMER OF IMPLIED WARRANTIES & CONSEQUENTIAL DAMAGES

Belco Resources Equipment obligation under this limited warranty, to the extent allowed by law, is in lieu of all warranties, implied or expressed, including implied warranties of merchantability and fitness for a particular purpose and any liability for incidental and consequential damages with respect to the sale or use of the items warranted. Such incidental and consequential damages shall include but not be limited to: transportation charges other than normal freight charges; cost of installation other than cost approved by Belco Resources Equipment; duty; taxes; charges for normal service or adjustment; loss of crops or any other loss of income; rental of substitute equipment, expenses due to loss, damage, detention or delay in the delivery.

## REGISTRATION

The online Warranty Registration must be completed in order to qualify for coverage on this Limited Warranty. Visit [br-equipment.com](http://br-equipment.com), click on "Warranty Registration" and completely fill out the form to register the new piece of equipment.

**Page left blank intentionally**



401 Jeffreys Road  
Rocky Mount, NC 27804  
[www.tarrivermfg.com](http://www.tarrivermfg.com)

Tel: 252-822-7140  
Fax: 252-787-5855  
[Sales@tarrivermfg.com](mailto:Sales@tarrivermfg.com)