

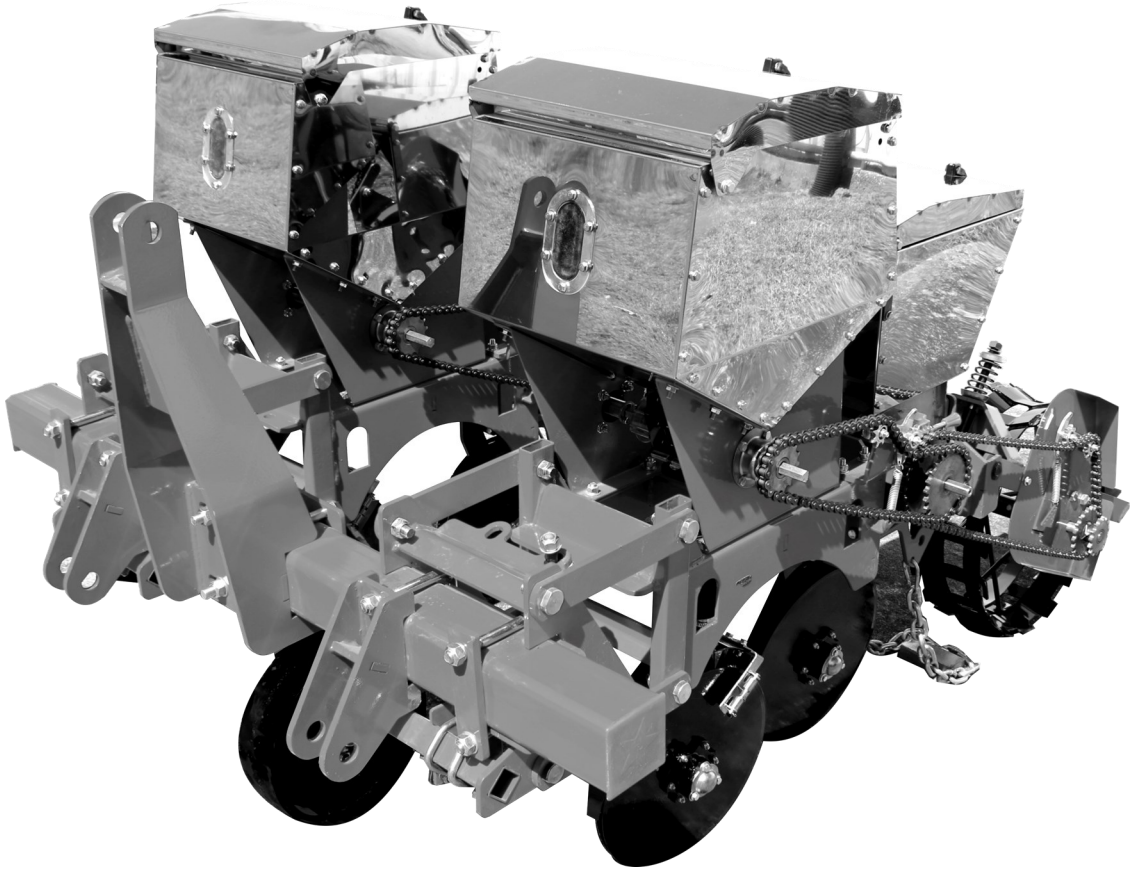

Corn Seed Planter

CSP-2R, CSP-4R



Operator's Manual

Rel. 12/25

Page left blank intentionally

TO THE DEALER:

Assembly and proper installation of this product is the responsibility of the Tar River dealer. Read manual instructions and safety rules. Make sure all items on the Dealer's Pre-Delivery and Delivery Check Lists in the Owner's/Operator's Manual are completed before releasing equipment to the owner.

TO THE OWNER:

Read this manual before operating your Tar River equipment. The information presented will prepare you to do a better and safer job. Keep this manual handy for ready reference. Require all operators to read this manual carefully and become acquainted with all the adjustment and operating procedures before attempting to operate. Replacement manuals can be obtained from your selling dealer. The equipment you have purchased has been carefully engineered and manufactured to provide dependable and satisfactory use. Like all mechanical products, it will require cleaning and upkeep. Lubricate the unit as specified. Observe all safety information in this manual and safety decals on the equipment. For service, your authorized Tar River dealer has trained mechanics, genuine Tar River service parts, and the necessary tools and equipment to handle all your needs. Use only genuine Tar River service parts. Substitute parts will void the warranty and may not meet standards required for safe and satisfactory operation.

Record your implement model and serial number in the space provide below. Your dealer will need this information to give you prompt, efficient service.

Model Number: _____

Serial Number: _____

Date Purchased: _____

TO THE DEALER: Part 1 of 2

Assembly and proper installation of this product is the responsibility of the Belco Resources Dealer. Read manual instructions and safety rules. Make sure all items on the Dealer's Pre-Delivery List and Owners Check List in the Owner's/Operator's Manual are completed before releasing equipment to the owner.



NOTE: The machine must be inspected thoroughly by the dealer prior to delivery of machine to owner. Place a check mark in the box beside each item checked. Contact Belco Recourses Equipment of any damages, issues or shortages to the machine.

Pre-Delivery Checklist - Dealer

- Gearbox oil level
- Check all fluids, hydraulic, gear oil, etc.
- Grease fittings properly lubricated
- Guards, shields, attachments securely fastened
- All hardware tightened
- Condition and tension of V-belts (if applicable)
- Blades properly installed, blade hardware tightened to proper torque specifications
- PTO attached to the machine (if applicable)
- All decals are clean, legible and in proper location
- Operator's Manual on machine

Model #: _____ Serial #: _____

Inspected by (Initials): _____ Date: _____

TO THE DEALER: Part 2 of 2

Dealer is to review the following items to the owner. Place a check mark in the box beside each item reviewed.

Checklist - Owner

- Correct attachment of machine to tractor
- Safe operation of the machine
- Importance of regular lubrication, maintenance and inspection
- Troubleshooting
- Replacing broken or worn parts (importance of using only OEM parts)
- Servicing the machine
- Storage
- Warranty
- Encourage owner to read and understand the Operator's Manual before operating the machine
- Encourage owner to fill out the "Warranty Registration", online warranty@br-equipment.com

Purchase Date: _____ **Delivery Date:** _____

Model #: _____ **Serial #:** _____

Dealer Signature _____ **Date:** _____

Customer Signature _____ **Date:** _____

TO THE OWNER:

Read this manual before operating your Belco Resources equipment. The information presented will prepare you to do a better and safer job. Keep this manual handy for ready reference. Require all operators to read this manual carefully and become acquainted with all the adjustment and operating procedures before attempting to operate. Replacement manuals can be obtained from your selling dealer. The equipment you have purchased has been carefully engineered and manufactured to provide dependable and satisfactory use. Like all mechanical products, it will require cleaning and upkeep. Lubricate the machine as specified. Observe all safety information in this manual and safety decals on the equipment. For service, your authorized Belco Resources dealer has trained mechanics, genuine Belco Resources service parts, and the necessary tools and equipment to handle all your needs. Use only genuine Belco Resources service parts. Substitute parts will void the warranty and may not meet standards required for safe and satisfactory operation.

Table of Contents

Introduction	7
Technical Specifications	7
Safety	8
Safety Signal Words	8
General Safety Guidelines	9
Safety Decal Care	9
Before Operation	10
During Operation	11
Highway And Transport Operations	12-13
General Design.....	14
Attaching to Tractor.....	15
Operating Instructions	16-23
Seed Spacing Charts.....	24-25
Trouble Shooting.....	26
Lubrication and Maintenance.....	27
Torque Specifications	28
Parts Breakdown	29-53
Warranty	54

Technical Specifications

Thank you for purchasing your Tar River Seed Planter. Tar River Seed Planter is an excellent choice for planting Corn, Soybean, Sorghum or Millet. Built to last with stainless steel seed and fertilizer hoppers the CSP-2R or CSP-4R are cost effective units for small farmers. Both the 2 Row and 4 Row Units come standard with Corn and Soybean plates, optional Sorghum and Millet plates are available, See Table “Optional Equipment” below.

The CSP-4R 4-row units comes standard with hydraulically lifting row markers, which requires 1 remote.

Technical Specifications

Model	CSP-2R	CSP-4R
HP	35	60
Hitch	Cat. 1	Cat. 1
Weight	425 lbs.	925 lbs.

Optional Equipment

Part #	Description
CSP-SGP	Sorghum Plate Assembly
CSP-MLP	Millet Plate Assembly
CSP-RM	Row Markers (Hydraulic lift) *Standard on the CSP-4R

Important Safety Information

Safety

It is important that you read the entire manual and to become familiar with this product before you begin using it. This product is designed for certain applications only. The manufacturer cannot be responsible for issues arising from modification. We strongly recommend this product not be modified and /or used for any application other than that for which it is designed. If you have any questions relative to a particular application, DO NOT use the product until you have first contacted us to determine if it can or should be performed on the product.

Read and understand this manual and all safety signs before operating and maintaining . Review the safety instructions and precautions annually.

Safety Signal Words

TAKE NOTE! This safety alert symbol found though out this manual is used to call you attention to instructions involving you personal safety and the safety of others. Failure to follow these instructions can result in injury or death.



**This symbol means:
Attention!
Become alert!
Your safety is involved!**

Note the use of the signal words, **DANGER**, **WARNING** and **CAUTION** with the safety messages. The appropriate signal word for each has been selected using the following guidelines:



DANGER: Indicates an imminently hazardous situation that, if not avoided, will result in death or serious injury. This signal word is to be limited to the most extreme situations typically for machine components which, for functional purposes, cannot be guarded.



WARNING: Indicates a potentially hazardous situation that, if not avoided, could result in death or serious injury, and includes hazards that are exposed when guards are removed. It may also be used to alert against unsafe practices.



CAUTION: Indicates a potentially hazardous situation that, if not avoided, may result in minor or moderate injury. It may also be used to alert against unsafe practices.

Important Safety Information

General Safety Guidelines

Safety of the operator is one of the main concerns in designing and developing a new piece of equipment. Designers and manufacturers build in as many safety features as possible. However, every year many accidents occur which could have been avoided by a few seconds of thought and a more careful approach to handling equipment. You, the operator, can avoid many accidents by observing the following precautions in this section. To avoid personal injury, study the following precautions and insist those working with you, or for you, follow them.

Replace any **DANGER, WARNING, CAUTION** or instruction safety decal that is not readable or is missing. Location of such decals are indicated in this manual. Do not attempt to operate this equipment under the influence of drugs or alcohol.

Review the safety instructions with all users annually.

This equipment is dangerous to children and persons unfamiliar with its operation. The operator should be a responsible adult familiar with farm machinery and trained in this equipment's operations. **Do not allow persons to operate or assemble this unit until they have read this manual and have developed a thorough understanding of the safety precautions and of how it works.**

To prevent injury of death, use a tractor equipped with a Roll Over Protection System (ROPS). Do not paint over, remove or deface any signs or warning decals on your equipment. Observe all safety signs and practice the instructions on them.

Never exceed the limits of a piece of machinery. If its ability to do a job, or to do so safely, is in question - **Don't try it!**



Safety Decal Care

- Keep safety signs clean and legible at all times.
- Replace safety signs that are missing or have become illegible.
- Replaced parts that displayed a safety sign should also display the current safety sign
- Safety signs are available from your Distributor or Dealer Parts Department or the factory.

Important Safety Information

How to Install Safety Signs

- Be sure that the installation area is clean and dry.
- Decide on the exact position before you remove the backing paper.
- Remove the smallest portion of the split backing paper.
- Align the decal over the specified area and carefully press the small portion with the exposed sticky backing in place.
- Slowly peel back the remaining paper and carefully smooth the remaining portion of the decal in place.
- Small air pockets can be pierced with a straight pin and smoothed out using the piece of decal backing paper.



Before Operation

- Carefully study and understand this manual.
- Do not wear loose-fitting clothing, which may catch in moving parts.
- Always wear protective clothing and substantial shoes.
- Assure that all tires are inflated evenly.
- Give the machine a visual inspection for any loose bolts, worn parts or cracked welds, and make necessary repairs. Follow the maintenance safety instructions included with this manual.
- Be sure that there are no tools lying on or in the equipment.
- Do not use the machine until you are sure that the area is clear, especially of children and animals.
- Don't hurry the learning process or take the machine for granted. Ease into it and become familiar with your new equipment.
- Practice operation of your equipment and its attachments. Completely familiarize yourself and other operators with its operation before using.
- Use a tractor equipped with a Roll Over Protection System (ROPS) and fasten your seat belt prior to starting engine.
- The manufacturer does not recommend usage of tractor with ROPS removed.
- Move tractor wheels to the widest recommended settings to increase stability.
- Securely attach to towing unit. Use a high strength, appropriately sized hitch pin with a mechanical retainer and attach safety chain.
- Do not allow anyone to stand between the tongue or hitch and the towing vehicle when backing up to the equipment.

Important Safety Information



During Operation

- Children should not be allowed on the product.
- Clear the area of small children and bystanders before moving the machine.
- If using a towing unit, securely attach machine by using a hardened 3/4" pin, a metal retainer, and safety chains if required. Shift towing unit to a lower gear before going down steep downgrades, thus using the engine as a retarding force. Keep towing vehicle in gear at all times. Slow down for corners and rough terrain.
- Make sure you are in compliance with all local and state regulations regarding transporting equipment on public roads and highways. Lights and slow moving signs must be clean and visible by overtaking or oncoming traffic when machine is transported.
- Beware of bystanders, **particularly children!** Always look around to make sure that it is safe to start the engine of the towing vehicle or move the machine. This is particularly important with higher noise levels and quiet cabs, as you may not hear people shouting.
- **NO PASSENGERS ALLOWED!** Do not carry passengers anywhere on, or in, the tractor or equipment, except as required for operation.
- Keep hands and clothing clear of moving parts.
- Do not clean, lubricate or adjust your equipment while it is moving.
- When halting operation, even periodically, set the tractor or towing vehicle brakes, disengage the PTO, shut off the engine and **remove the ignition key.**
- Be especially observant of the operating area and terrain. Watch for holes, rocks or hidden hazards. Always inspect the area prior to operation.
- **DO NOT** operate near the edge of drop-offs or banks.
- **DO NOT** operate on steep slopes as overturns may result.
- Operate up and down (not across) intermediate slopes. Avoid sudden starts and stops.



Warning: Never backup with the machine on the ground! This will cause damage to the machine. Always lift the machine high enough to clear the ground before backing up.

Important Safety Information



Highway and Transport Operations

- Adopt safe driving practices.
- Keep the brake pedals latched together at all times. **Never use independent braking with machine in tow as loss of control and/or upset of machine can result.**
- Always drive at a safe speed relative to local conditions and ensure that your speed is low enough for an emergency stop to be safe and secure. Keep speed at a minimum.
- Reduce speed prior to turns to avoid the risk of overturning.
- Avoid sudden uphill turns on steep slopes.
- Always keep the tractor or towing vehicle in gear to provide engine braking when going downhill. Do not coast.
- Do not drink and drive!
- Comply with state and local laws governing highway safety and movement of farm machinery on public roads.
- Use approved accessory lighting flags and necessary warning devices to protect operators of other vehicles on the highway during daylight and nighttime transport. Various safety lights and devices are available from your dealer.
- The use of flashing amber lights is acceptable in most localities. However, some localities prohibit their use. Local laws should be checked for all highway and marking requirements.
- When driving the tractor and equipment on the road or highway under 40 kph (20 mph) at night or during the day, use the amber warning lights and a slow moving vehicle (SMV) identification emblem.
- Plan your route to avoid heavy traffic.
- Be a safe and courteous driver. Always yield to oncoming traffic in all situations, including narrow bridges, intersections, etc.
- Be observant of bridge loading ratings. Do not cross bridges rated at lower than the gross weight at which you are operating.
- Watch for obstructions overhead and to the side while transporting.
- Always operate in a position to provide maximum visibility at all times. Make allowances for increased length and weight of the equipment when making turns, stopping the machine, etc.
- Pick the most level route when transporting across fields. Avoid the edges of ditches or gullies and steep hillsides.
- Be extra careful when working in inclines.

Important Safety Information



Highway and Transport Operations

- Maneuver the tractor or towing vehicle at safe speeds.
- Avoid overhead wires or other obstacles. Contact with overhead lines could cause serious injury or death.
- Avoid loose fill, rocks and holes, they can be dangerous for equipment operation or movement.
- Allow for machine length when making turns,
- Operate the towing vehicle from the operator's seat only.
- Never stand alongside of machine with engine running or attempt to start engine and/or operate machine while standing alongside of machine.
- Never leave running equipment attachments unattended.
- As a precaution, always recheck the hardware on equipment following every 100 hours of operation. Correct all problems. Follow the maintenance safety procedures.

General Design

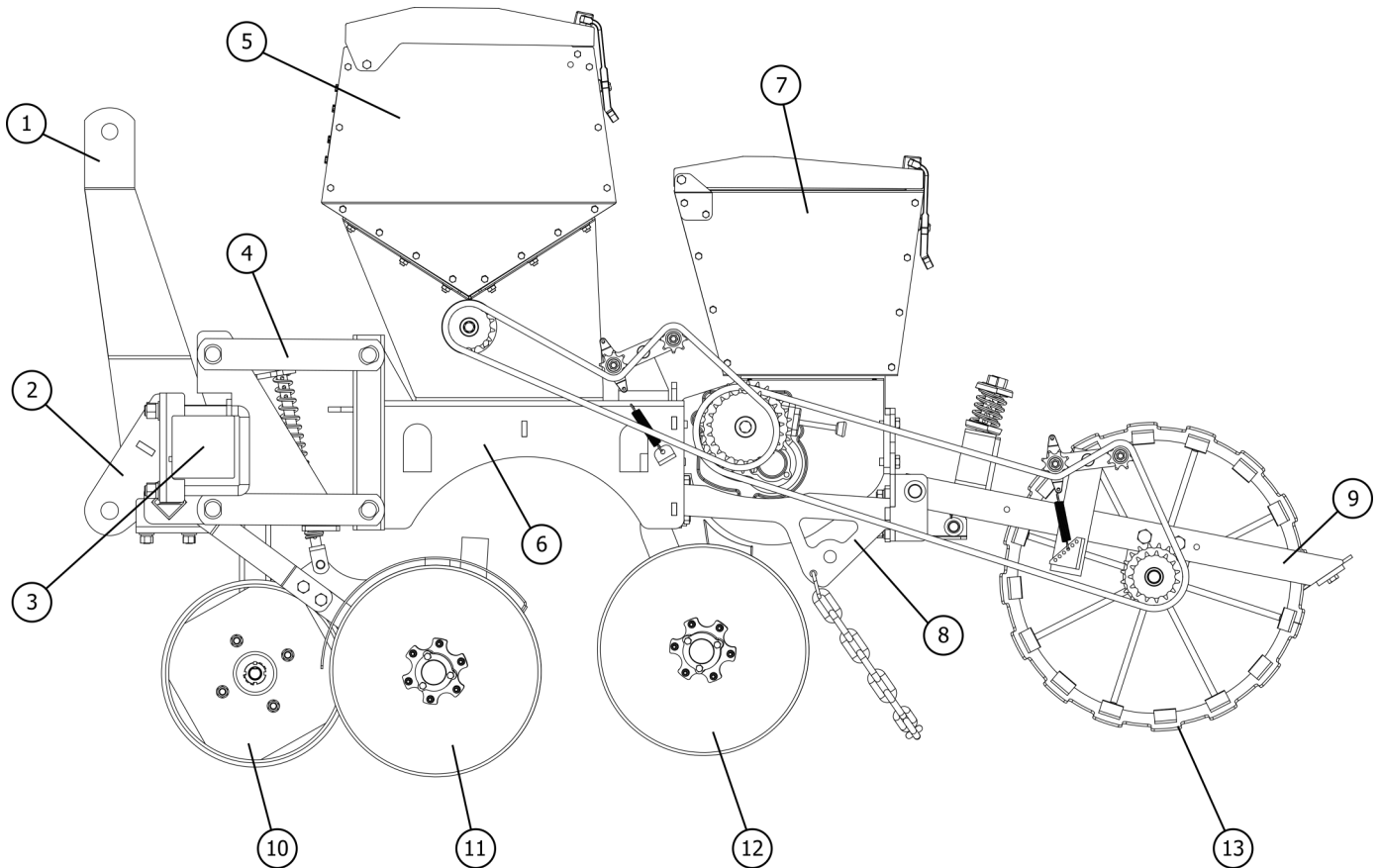

1. Upper Hitch
2. Lower Hitch
3. Main Beam
4. Front Support
5. Front Hopper - Fertilizer
6. Front Hopper - Fertilizer Base
7. Rear Hopper - Seed
8. Front/Rear Link Support
9. Drive Roller Support
10. Depth Limit Roller
11. Front Disc Opener
12. Rear Disc Opener
13. Drive Roller

Attaching to Tractor



Warning: When attaching the machine, *Never* allow anyone to stand between the machine and the tractor. Serious injury or death can occur!

Attaching the Machine

- Back up the tractor to the machine , while lining up the lower tractor links to the machine lower pins.
- Stop the engine, set the brake and remove the key from the tractor and block the tractor tires.
- Secure the lower tractor arms to the wood chipper lower pins with lynch pins.
- Attach the tractor top link to the machine with the top link pin and r-clip.
- Adjust the tractor sway bars/chains to center the machine and remove excess sway.
- Adjust lower links and top link so that the machine is level.
- Operate the tractor hydraulic controls very slowly up and down. There should be no contact between the machine or any part of the tractor. Failure to check clearance can result in damage to the machine, tractor (especially the tires) and possible injury to the operator. Maintain no less than 6” of clearance between the machine, tractor and tractor tires throughout the complete range of motion.

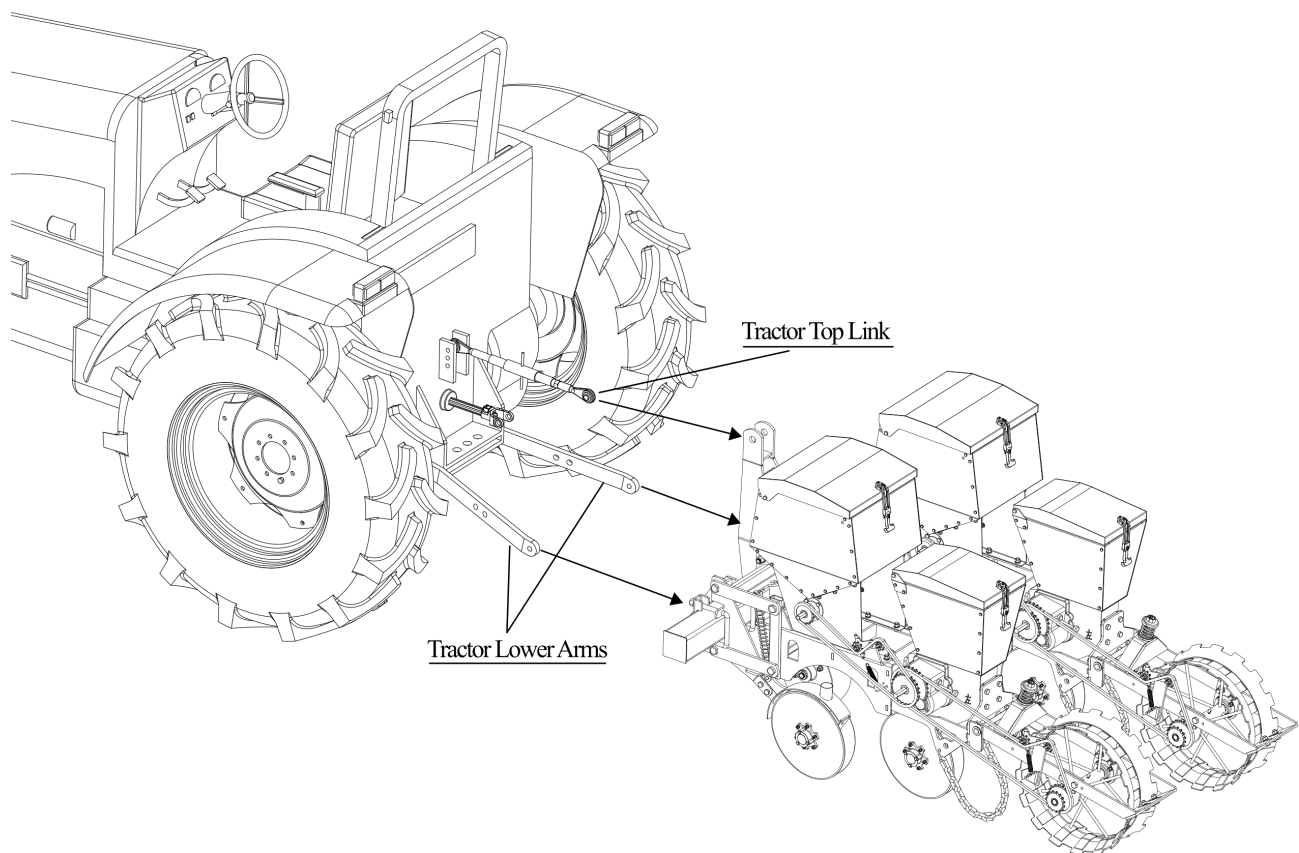

Warning: Never backup with the machine on the ground! This will cause damage to the machine. Always lift the machine high enough to clear the ground before backing up.

Operating Instructions

Adjusting Flow Rate of Material:

It is important to loosen the Locking Knob prior to turning the Rate Adjustment Handle. The Locking Knob sits in a groove on the Adjustment Handle and if not loosened first, can cause damage to threads. Loosen the Locking Knob to the point where it clears the threads of the Adjustment Handle. When tightening the Locking Knob, be sure it sits in the groove, not on the threads. The seed/fertilizer rate depends on the seed/fertilizer you want to plant. Always refer to your seed/fertilizer supplier's chart to get the proper seed/fertilize rate.

NOTE: Weight, size, relative humidity, and moisture content can affect seeding rates.

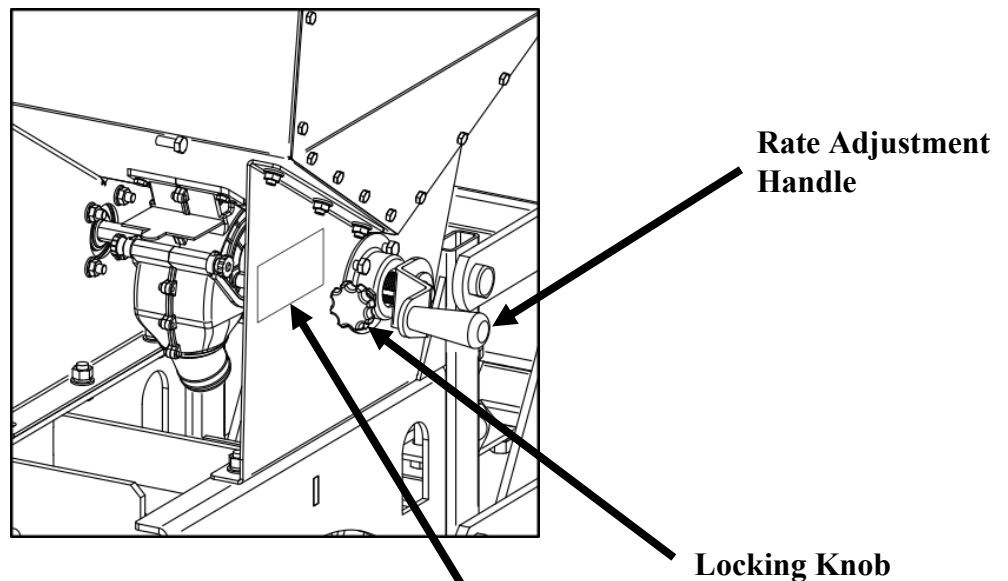

Caution!

Adjustment handle:

To adjust the fertilizer rate, loosen the Locking Knob before attempting to adjust the feed rate. **Note: the Locking Knob sits in a groove on the Adjustment Handle.** Loosen the Locking Knob to the point where it clears the threads of the Adjustment Handle. When tightening the Locking Knob, make certain it sits in the groove or the threads can be damaged.

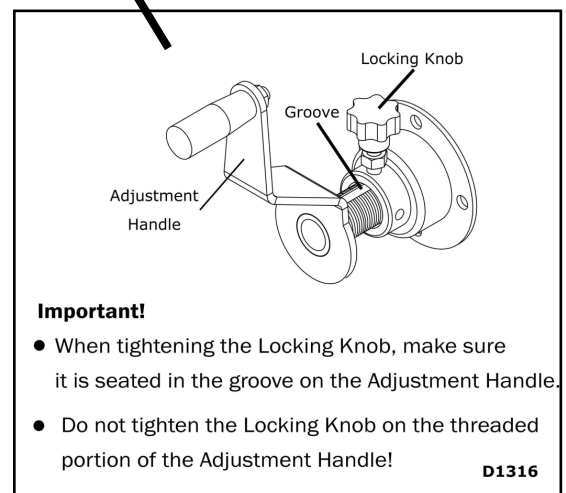

Decal located on LH side of front hopper

Operating Instructions

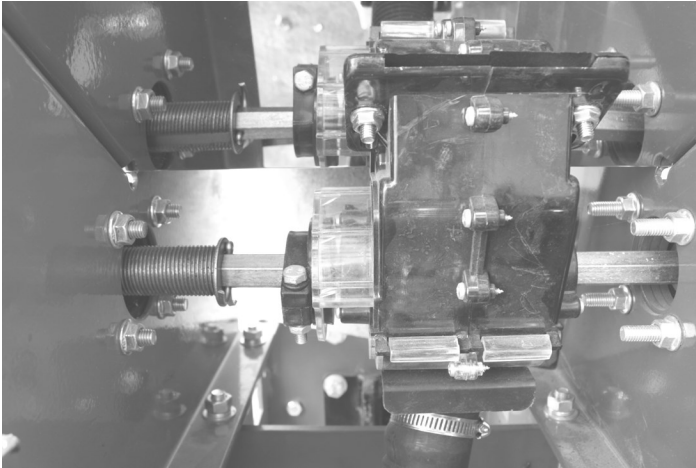

Minimum Output

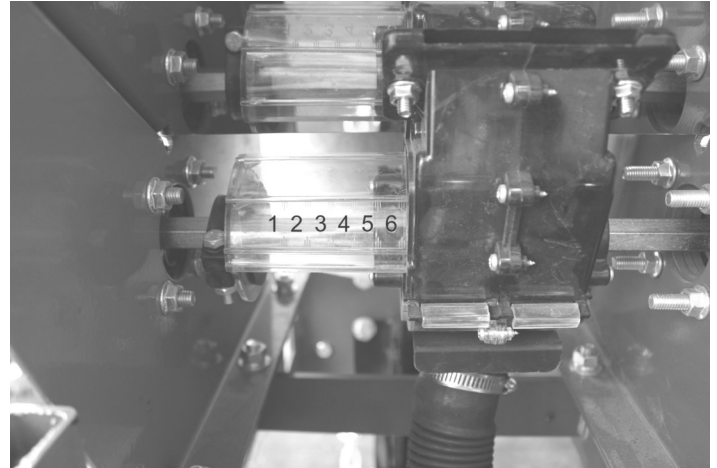

Maximum Output

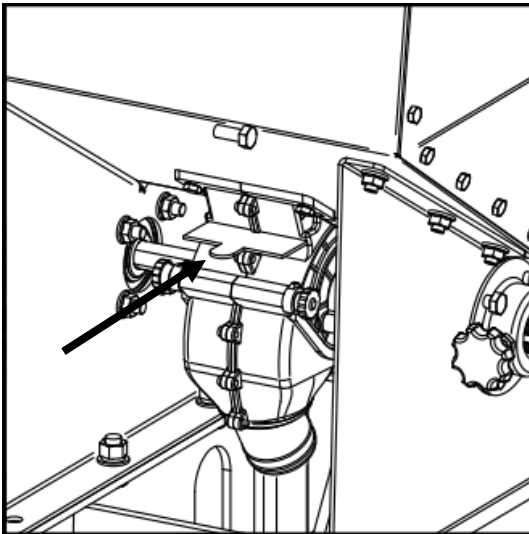

Shut Off Flap in closed position - No material dispensed

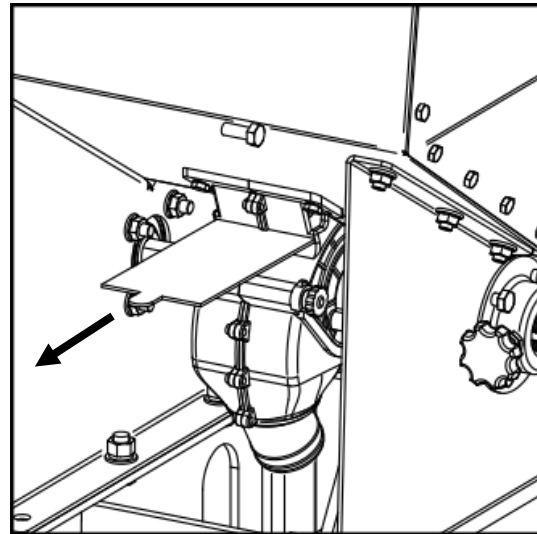

Shut Off Flap in open position

Operating Instructions

Seed Metering Unit

The spoon-clamping type seed-metering unit allows for fast operation speed, low miss-seeding rate and accurate seed metering. Seed metering can be monitored through the transparent side cover.

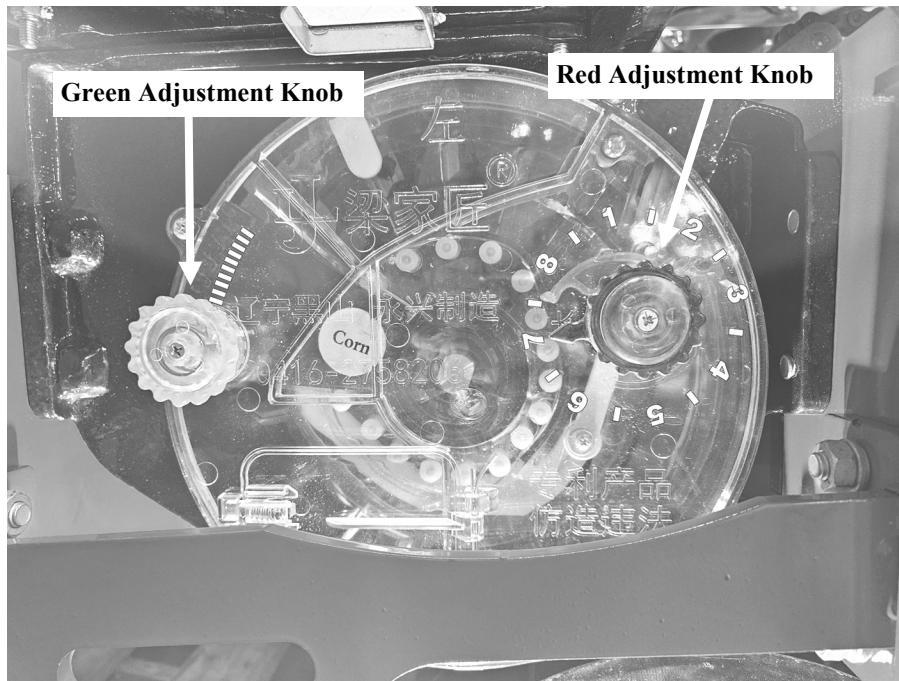

Precautions:

- Always fill the hopper in the field to avoid compacting the seeds during transportation.
- It is recommended to sort the seeds. Seeds similar in size tend to allow for more even seeding.
- Remove any foreign objects while adding seed to the hopper, rocks, sticks, etc. Foreign objects will cause damage to the seed metering unit.
- When replacing the seed metering side cover, place the red adjusting knob on the scale between 1 and 2. NOTE: Pull up on the red knob before attempting to turn. Attempting to turn the red knob without lift up first can cause damage to the gear on the back side of the cover plate. Once in desired position, the red knob can be released. Be sure the red knob locks securely in place. Re-install the four screws and tighten. Set the green knob to the highest setting to prevent empty cavities.

Operating Instructions

Prior to operation:

- Attach machine to the tractor and adjust the seed planter so it is level.
- With the seed planter securely attached to the tractor, lift the planter approximately 4" off the ground. Place seed in the hopper and rotate the drive wheel by hand. Inspect the seed clamping status through the side cover of the seed metering unit. If seeds are missing from the seed clamping port, adjust seed-metering unit. Repeat process until desired results are achieved.
- Due to varying sizes of seed, the seed-metering unit must be adjusted accordingly. Rotate the red adjustment knob to one of the 16 adjustments on the scale. Whole number adjustments, extend or retract the seed clamping port by 0.1 inch. Setting the pointer between whole numbers extends or retracts the seed clamping port by 0.05 inches.

Method of adjustment:

- Pull outward on the red adjustment knob and set pointer to a higher or lower number on scale. If seeds are missing from seed clamping port, adjust the pointer in small increments until all seed clamping ports are filled. There should be no empty ports. Too high a setting will result in more than one seed per port. Turn the pointer to a lower setting.

Adjust Seed-blocking Unit:

The seed-blocking unit is adjusted by the Green Knob on the metering unit. The seed-blocking unit controls the quantity of seed entering the seed-metering chamber. Pull up and rotating the green knob clockwise will increase the number of seeds entering the seed-metering chamber. Rotating the green knob counter-clockwise will decrease the number of seeds entering the seed-metering chamber.

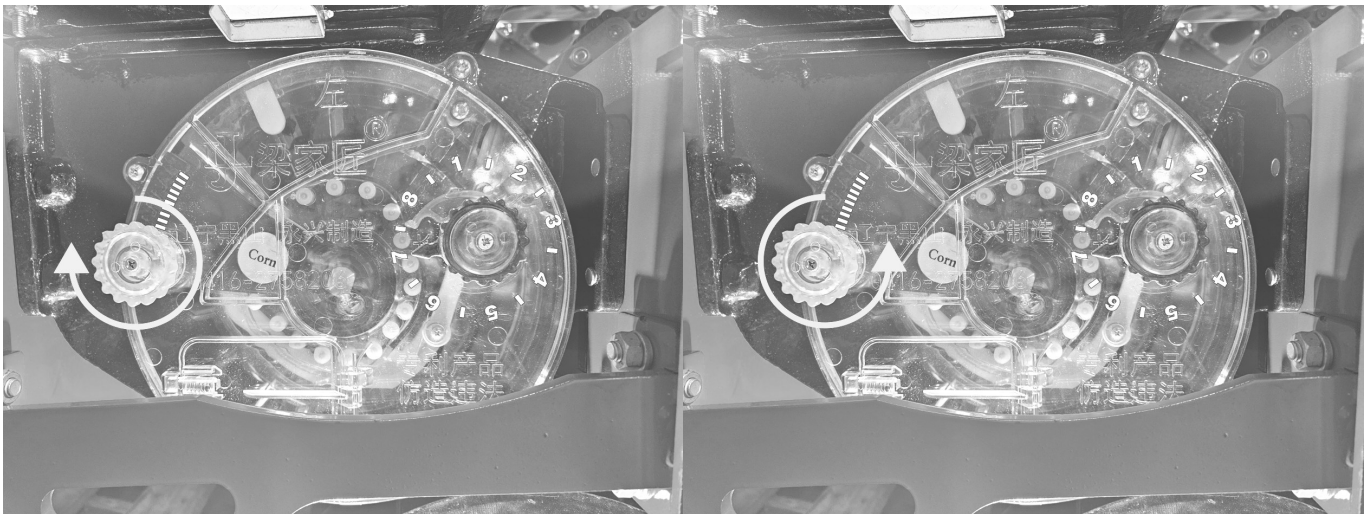

Increase seed quantity released to chamber.

Decrease seed quantity released to chamber.

Operating Instructions

Replacing Seed-Metering Plates:

- There are four seed-metering plates available. The seed planter comes standard with a corn metering plate and soybean metering plate. Optional millet metering plates and sorghum metering plates are available for purchase.

Standard Metering Plates

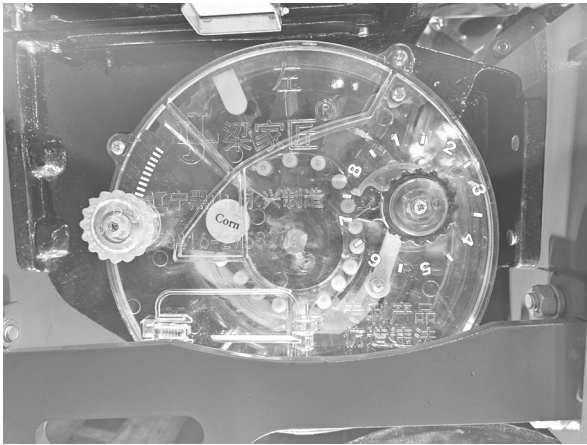

Corn Metering Plate



Soybean Metering Plate

Optional Metering Plates



Sorghum Metering Plate

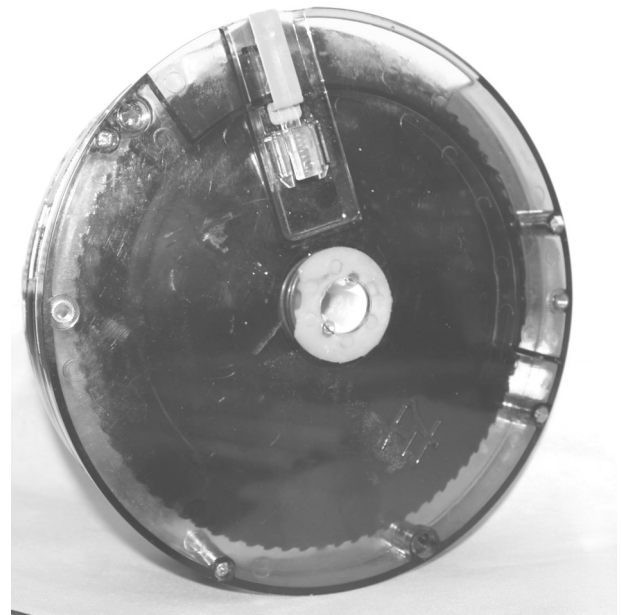

Millet Metering Plate

Operating Instructions

Assembling Corn Metering Plates:

- Slide the Corn Metering plate onto the shaft.
- Thread two long screws as shown, indicated by yellow arrows.
- Attach the cover to the seed metering unit using the 4 short screws and tighten.

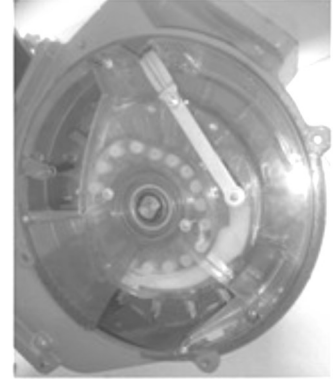
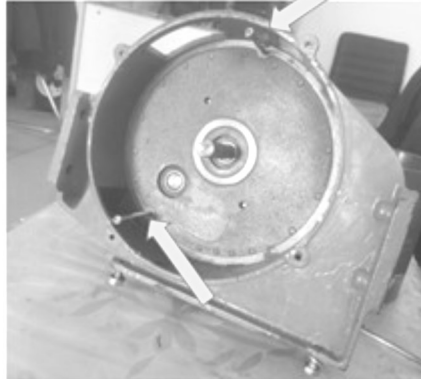

Assembling Soybean Metering Plates:

- Slide the Soybean Metering plate onto the shaft.
- Attach the cover to the seed metering unit using the 4 short screws and tighten.

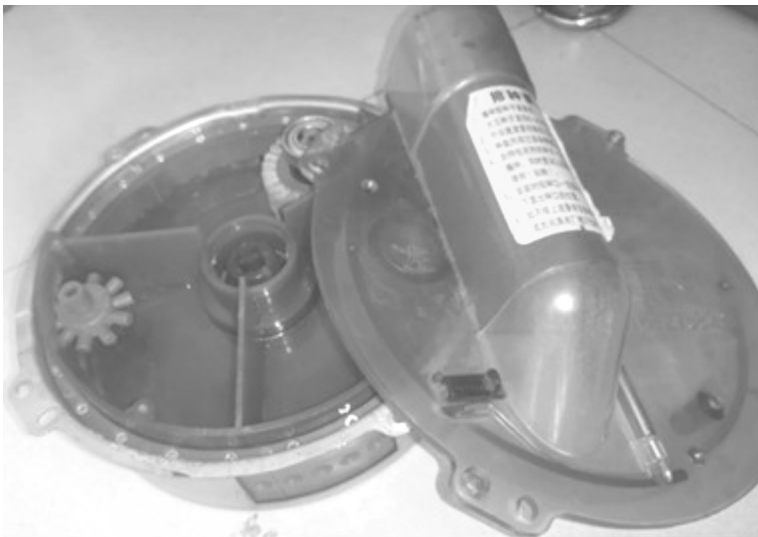

Operating Instructions

Assembling Sorghum Metering Plates:

- Slide the Sorghum Metering plate onto the shaft.
- Thread 1 long screw as shown, indicated by yellow arrows to attach to the seed-metering base.
- Attach the cover to the seed metering unit using the 4 short screws and tighten.



Seed Ports:

The Seed Port Plate must be rotated in proper position according to type of seed, see figure below. There are two positions for the Seed Port Plate. Position 1 is for (1) Corn, Sorghum and Millet, position (2) Soybean only.

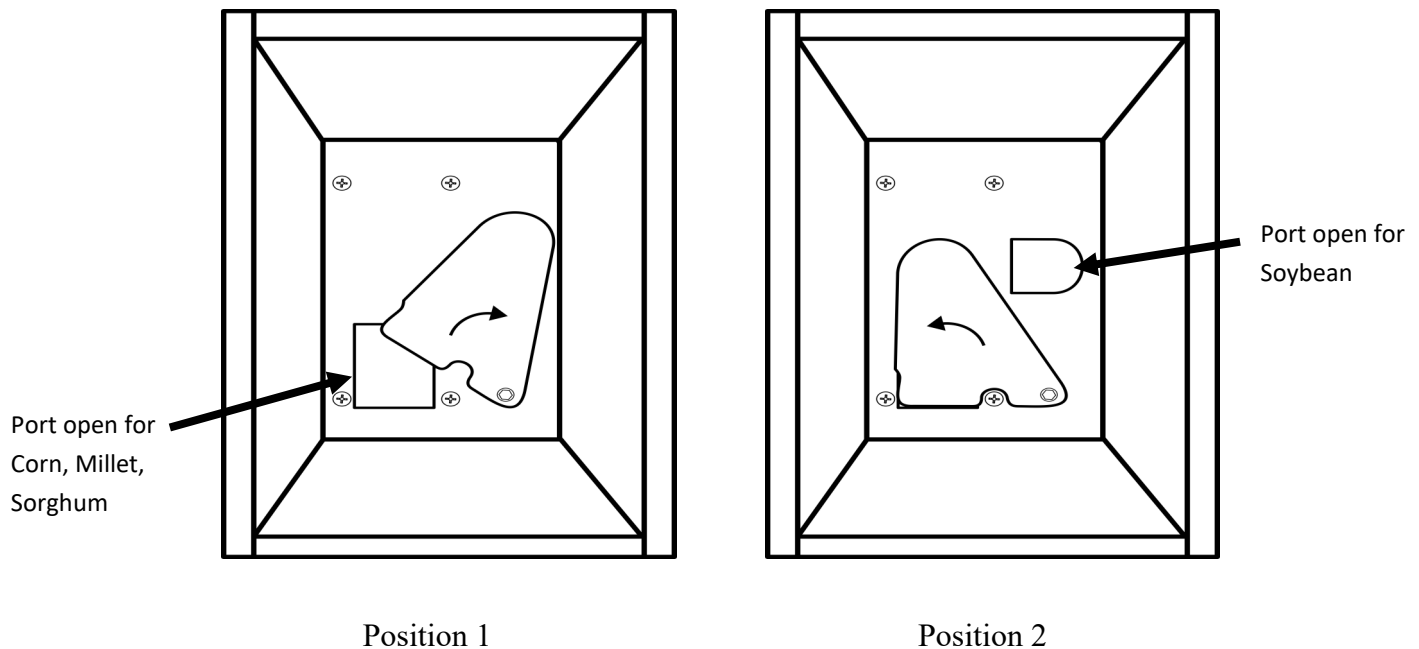

Operating Instructions

Ground drive wheel:

The Drive Roller supports the seeding assembly, controls seed planting depth and drives the fertilizer/seed metering units. Increase or decrease the down pressure on the ground drive wheel using the nut on top on the downforce rod.

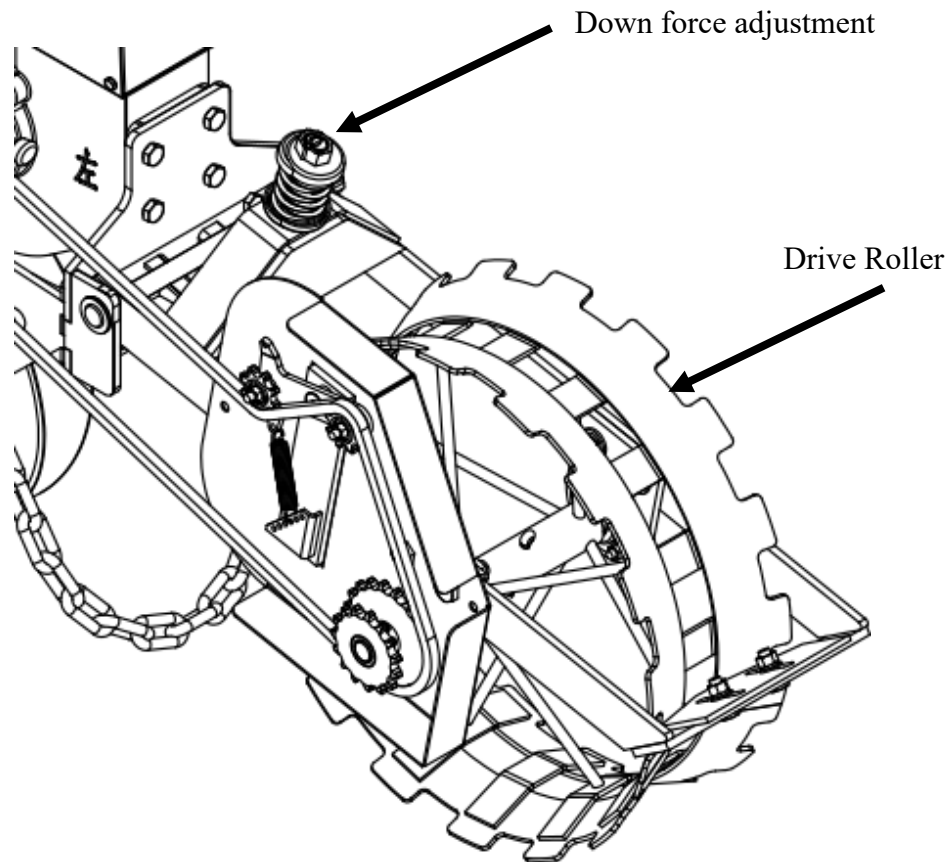

Plant Spacing Adjustment:

Adjust plant spacing by replacing the chain sprocket with different teeth on the ground wheel and the seed metering unit and matching with the gearbox gear.

Seed Spacing Chart

Seed Spacing Adjustment

Seed Spacing is accomplished by changing positions of the chain on the Seed Metering Sprocket, Drive Roller Sprocket and selecting gear positions accordingly. Note: Plant spacing is provided as a guide only. The actual rates will vary due to slippage of the Drive Roller. Slippage rate of Drive Roller is calculated at 10%.

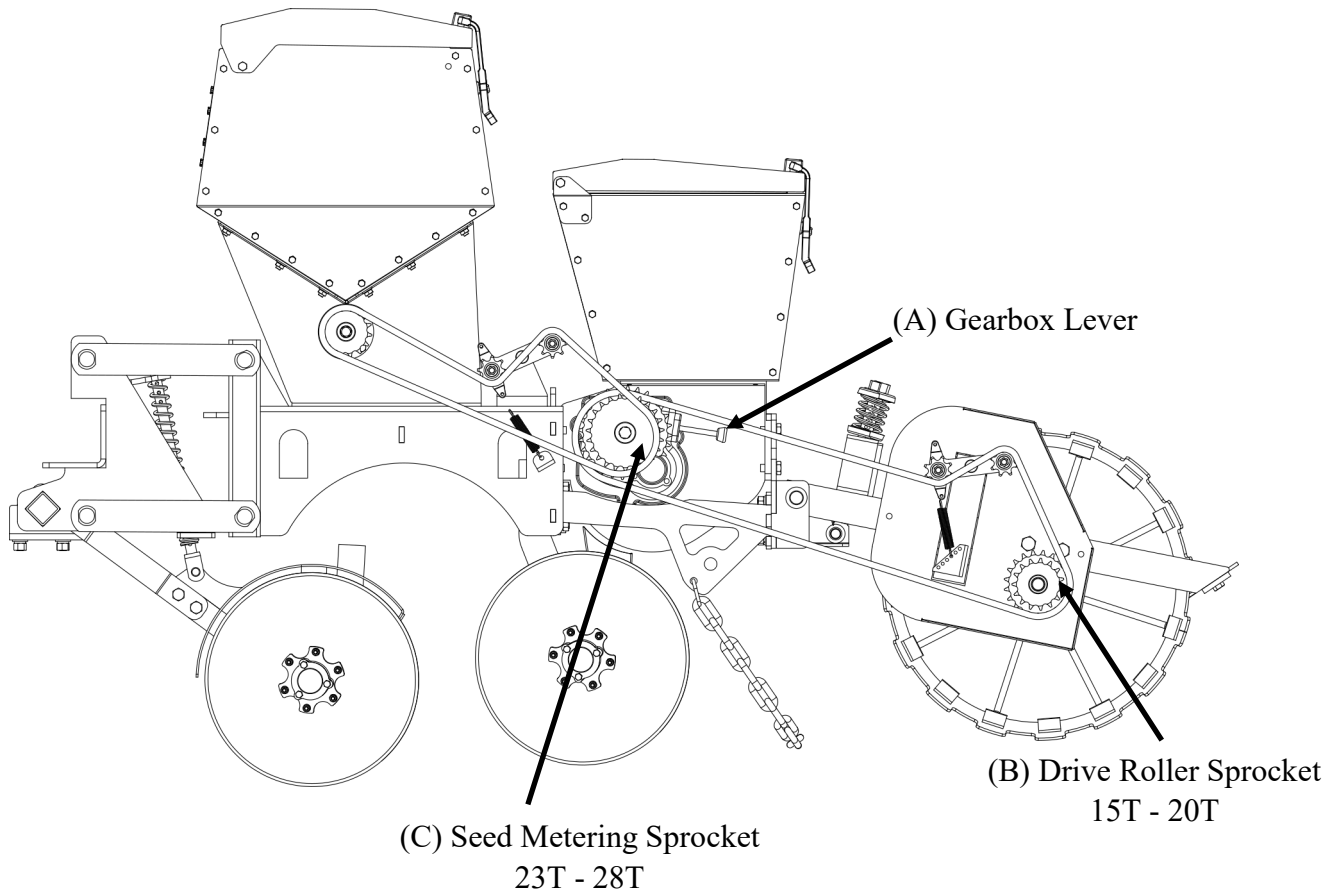

(A) Gear box Lever Position	(B) Drive Roller Sprocket	(C) Seed Metering Sprocket	Number of Corn seed per plate	Corn seed spacing (inch)	Number of Soybean seed per plate	Soybean seed spacing (inch)	Number of Sorghum seed per plate	Sorghum seed spacing (inch)
1	15	28	18	5.9	50	2.1	42	2.6
2	15	28	18	7.1	50	2.6	42	3.1
3	15	28	18	8.3	50	3	42	3.5
4	15	28	18	9.5	50	3.4	42	4.1
5	15	28	18	10.7	50	3.7	42	4.6
6	15	28	18	11.9	50	4.3	42	5.1
7	15	28	18	13	50	4.7	42	5.6

Seed Spacing Chart

(A) Gear box Lever Position	(B) Drive Roller Sprocket	(C) Seed Metering Sprocket	Number of Corn seed per plate	Corn seed spacing (inch)	Number of Soybean seed per plate	Soybean seed spacing (inch)	Number of Sorghum seed per plate	Sorghum seed spacing (inch)
1	20	28	18	4.5	50	1.6	42	1.9
2	20	28	18	5.4	50	1.9	42	2.3
3	20	28	18	6.2	50	2.2	42	2.7
4	20	28	18	7.1	50	2.6	42	3.1
5	20	28	18	8	50	2.9	42	3.4
6	20	28	18	8.9	50	3.2	42	3.8
7	20	28	18	9.7	50	3.5	42	4.2

(A) Gear box Lever Position	(B) Drive Roller Sprocket	(C) Seed Metering Sprocket	Number of Corn seed per plate	Corn seed spacing (inch)	Number of Soybean seed per plate	Soybean seed spacing (inch)	Number of Sorghum seed per plate	Sorghum seed spacing (inch)
1	20	23	18	3.7	50	1.3	42	1.6
2	20	23	18	4.4	50	1.6	42	1.9
3	20	23	18	5.1	50	1.9	42	2.2
4	20	23	18	5.9	50	2.1	42	2.5
5	20	23	18	6.6	50	2.4	42	2.8
6	20	23	18	7.4	50	2.6	42	3.1
7	20	23	18	8	50	2.9	42	3.4

(A) Gear box Lever Position	(B) Drive Roller Sprocket	(C) Seed Metering Sprocket	Number of Corn seed per plate	Corn seed spacing (inch)	Number of Soybean seed per plate	Soybean seed spacing (inch)	Number of Sorghum seed per plate	Sorghum seed spacing (inch)
1	15	23	18	4.9	50	1.8	42	2.1
2	15	23	18	5.9	50	2.1	42	2.5
3	15	23	18	6.9	50	2.5	42	2.9
4	15	23	18	7.8	50	2.8	42	3.3
5	15	23	18	8.8	50	3.1	42	3.8
6	15	23	18	9.8	50	3.5	42	4.2
7	15	23	18	10.7	50	3.9	42	4.6

Trouble Shooting

Problem	Possible Cause	Possible Remedy
Seed damage	Seed port blockage	Remove material blocking port.
Missed seeding	Red adjusting knob improperly set	Re-adjust red adjusting knob, lift planter and turn ground engaging wheel to check.
	Seed clumping due to excessive seed coating agent in seed scoop	Clean seed scoop thoroughly.
	Seed wet due to coating agent	Set seed in sun to dry.
	Seed lubricant missing	Mix appropriate amount of lubricant
	Ground engage wheel slipping or not rotating	Examine the ground engage wheel and set to proper tension. Ground engage wheel must contact ground surface.
	Drive chain slipping	Tighten the drive chain jackscrew in increase tension.
Excessive seed	Amount of seed in chamber too high	Adjust the green knob (seed blocking plate) to decrease seed level.
	Seed spoon clamping set too high	Adjust the red knob (clamping spoons), raise planter and turn ground engage wheel to check status
Incorrect crop spacing	Incorrect gearbox setting	Re-adjust gearbox
	Drive chain rotation incorrect	Tighten the drive chain jackscrew in increase tension.
	Ground engage wheel slipping or not rotating	Determine if ground engage wheel has proper tension to drive chain.
Seed not distributed	Seed port blockage	Clean seed port. Remove blockage.
	Not enough seed in chamber	Adjust the green knob (seed blocking plate) to increase seed level.
Overfilling seed hopper	Seed metering unit not horizontal	Adjust the tractor linkage to level planter.
	Green adjustment knob not in proper position	Re-adjust green knob to decrease amount of seed. Lift planter, rotate the ground engage wheel to check status.
	Seed hopper is filled during transportation	Seed must be added only in the field. Seed in hopper can become compacted during transportation.

Lubrication and Maintenance

Planter Maintenance

Clean the machine after each use.

Check all fasteners and tighten if required after each use.

Check moving parts (chain, sprockets, etc.) for wear and lubricate after each use.

Prior to storing machine after planting season, thoroughly clean and dry.

Check for rusted or chipped parts. Clean and re-paint as necessary.

Repair or replace broken or worn parts. To avoid warranty issues, use only OEM parts.

Torque Specifications

Torque Specifications for Common Bolt Sizes															
Inches		Bolt Head Identification						Metric		Bolt Head Identification					
Bolt size (inches)	Thread pitch	Grade 2		Grade 5		Grade 8		Bolt size (metric)	Thread pitch	Class 5.8		Class 8.8		Class 10.9	
		N.m	ft-lb	N.m	ft-lb	N.m	ft-lb			N.m	ft-lb	N.m	ft-lb	N.m	ft-lb
1/4"	20	7	5	11	8	16	12	M5	0.08	4	3	6	4	9	7
1/4"	28	8	6	13	10	19	14	M6	1	6	4	10	7	15	11
5/16"	18	15	11	24	17	33	25	M8	1.25	16	12	25	18	36	27
5/16"	24	17	13	26	19	37	27	M8	1	17	13	26	19	38	28
3/8"	16	27	20	42	31	59	44	M10	1.5	31	23	48	35	71	52
3/8"	24	31	23	47	35	67	49	M10	1.25	33	24	51	38	75	55
7/16"	14	43	32	67	49	95	70	M10	1	35	26	53	39	78	58
7/16"	20	48	36	75	55	106	78	M12	1.75	54	40	84	62	123	91
1/2"	13	66	48	102	75	144	106	M12	1.5	56	41	87	64	128	94
1/2"	20	75	55	115	85	163	120	M12	1.25	59	44	90	66	133	98
9/16"	12	95	70	147	109	208	154	M14	2	84	62	133	98	195	144
9/16"	18	106	79	164	121	232	171	M14	1.5	94	69	142	105	209	154
5/8"	11	132	97	203	150	287	212	M16	2	131	97	206	152	302	223
5/8"	18	149	110	230	170	325	240	M16	1.5	141	104	218	161	320	236
3/4"	10	233	172	361	266	509	376	M18	2.5	181	133	295	218	421	310
3/4"	16	261	192	403	297	569	420	M18	2	196	145	311	229	443	327
7/8"	9	226	167	582	430	822	606	M18	1.5	203	150	327	241	465	343
7/8"	14	249	184	642	473	906	668	M20	2.5	256	189	415	306	592	437
1"	8	339	250	873	644	1232	909	M20	1.5	288	212	454	335	646	476
1"	12	371	273	955	704	1348	995	M22	2.5	344	254	567	418	807	595
1-1/8"	7	480	354	1077	794	1746	1288	M22	1.5	381	281	613	452	873	644
1-1/8"	12	539	397	1208	891	1958	1445	M24	3	444	327	714	526	1017	750
1-1/4"	7	677	500	1519	1120	2463	1817	M24	2	488	360	769	567	1095	808
1-1/4"	12	750	553	1682	1241	2728	2012	M27	3	656	484	1050	774	1496	1103
1-3/8"	6	888	655	1992	1469	3230	2382	M27	2	719	530	1119	825	1594	1176
1-3/8"	12	1011	746	2268	1673	3677	2712	M30	3.5	906	668	1420	1047	2033	1499
1-1/2"	6	1179	869	2643	1949	4286	3161	M30	2	1000	738	1600	1180	2250	1659
1-1/2"	12	1326	978	2974	2194	4823	3557	M36	4	1534	1131	2482	1830	3535	2607

Notes:

This chart is an approximate estimate of torque values.

Always tighten hardware to these values unless a different torque value or tightening procedure is listed for a specific application.

Fasteners must always be replaced with the same grade as specified in the manual.

Always use the proper tool for tightening hardware: SAE for SAE hardware and Metric for Metric hardware.



Corn Seed Planter

CSP-2R, CSP-4R

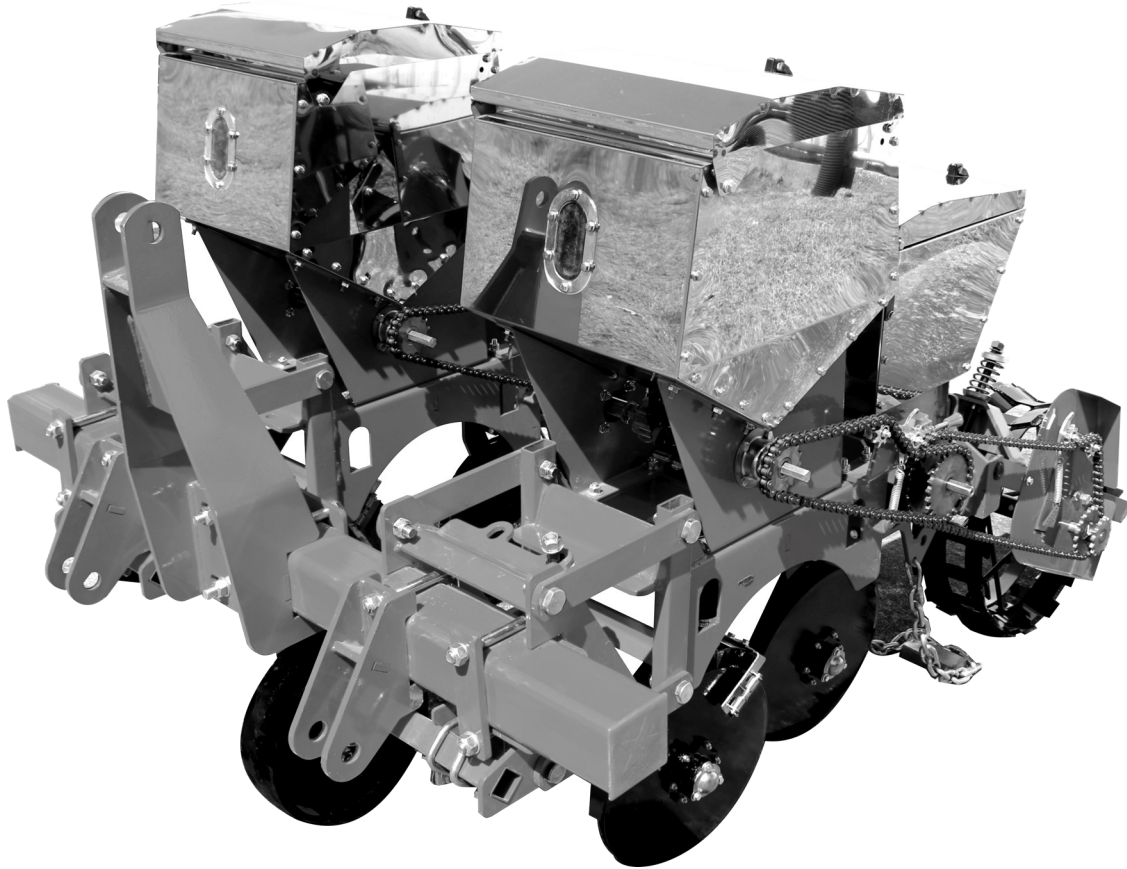

Parts Manual

Rel. 12/25

Metering Unit

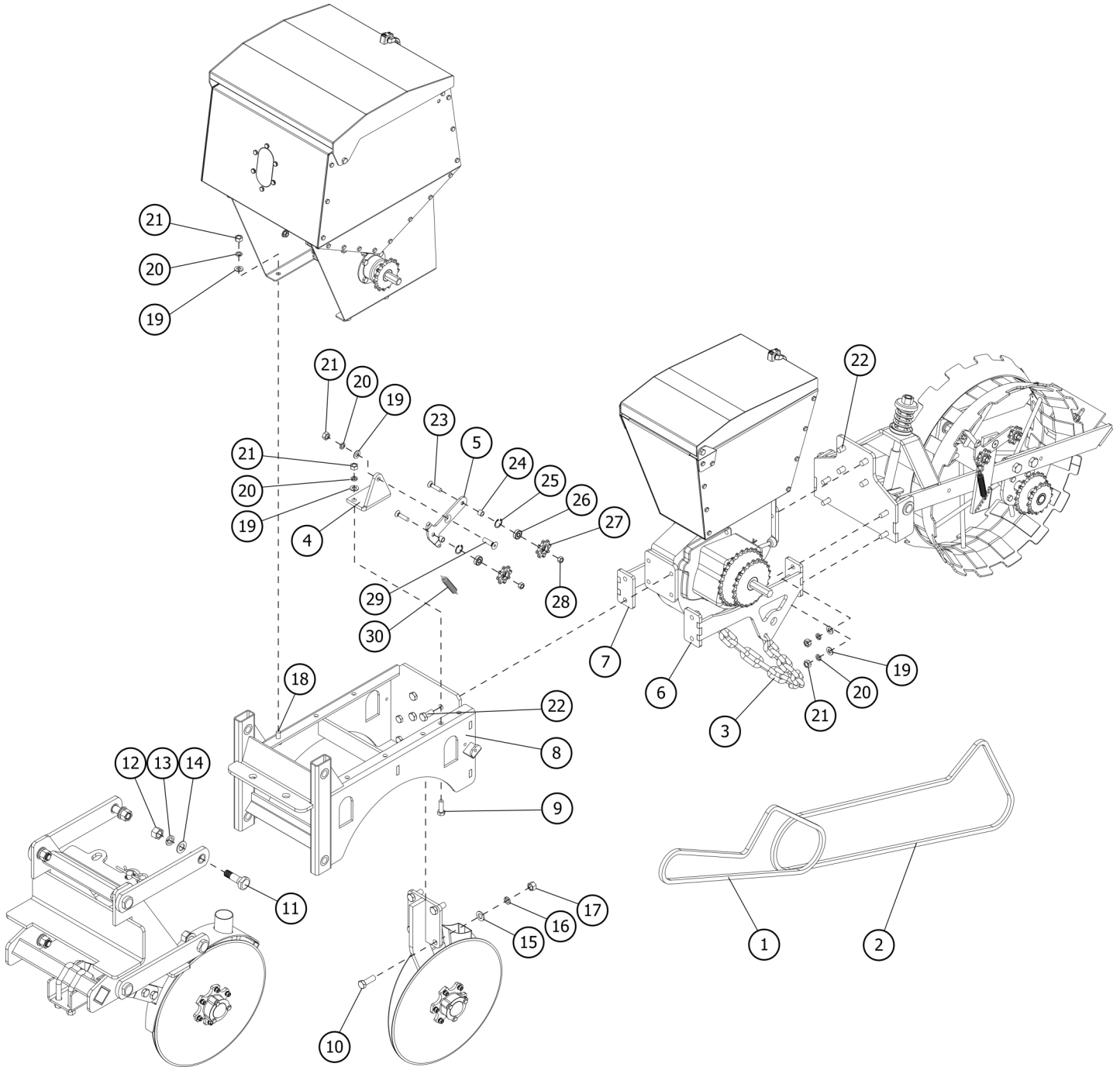

Metering Unit

Item	Part #	Description	Qty.
1	CSP40000	Chain, fertilizer hopper CSP	1
2	CSP40001	Chain, seed hopper CSP	1
3	CSP40002	Drag chain	1
4	CSP40003	Tensioner support mount	2
5	CSP40004	Idler arm CSP	1
6	CSP40005	Front & rear link support LH	1
7	CSP40006	Front & rear link support RH	1
8	CSP40007	Fertilizer hopper base frame	1
9	BM101530	Bolt HH M10-1.5x30	2
10	BM121535 FT 8.8	Bolt HH M12-1.5x35 full thread 8.8	4
11	CSP40008	Shoulder bolt support linkage M16-2.0	8
12	NM1620	Nut HH M16-2.0	8
13	LW16	Washer lock M16	8
14	FW16	Washer flat M16	8
15	FW12	Washer flat M12	8
16	LW12	Washer lock M12	8
17	NM1215	Nut HH M12-1.5	8
18	BM101525	Bolt HH M10-1.5x25	-
19	FW10	Washer flat M10	
20	LW10	Washer lock M10	
21	NM1015	Nut HH M10-1.5	
22	BM121525	Bolt HH M12-1.5x25	8
23	SSM0812535 NEW	Hex drive flat head screw M08-1.25x35	2
24	CSP40009	Idler spacer, drive wheel	2
25	SRI-22	Snap ring internal M22	2
26	B6082RS	Bearing 608 2RS	2
27	CSP40010	Idler sprocket, drive wheel	2
28	LNLM08125	Nut HH locking M08-1.25	2
29	SSM101530	Hex drive flat head screw M10-1.5x30	1
30	CSP40011	Idler spring	1

Main Frame - 2 Row

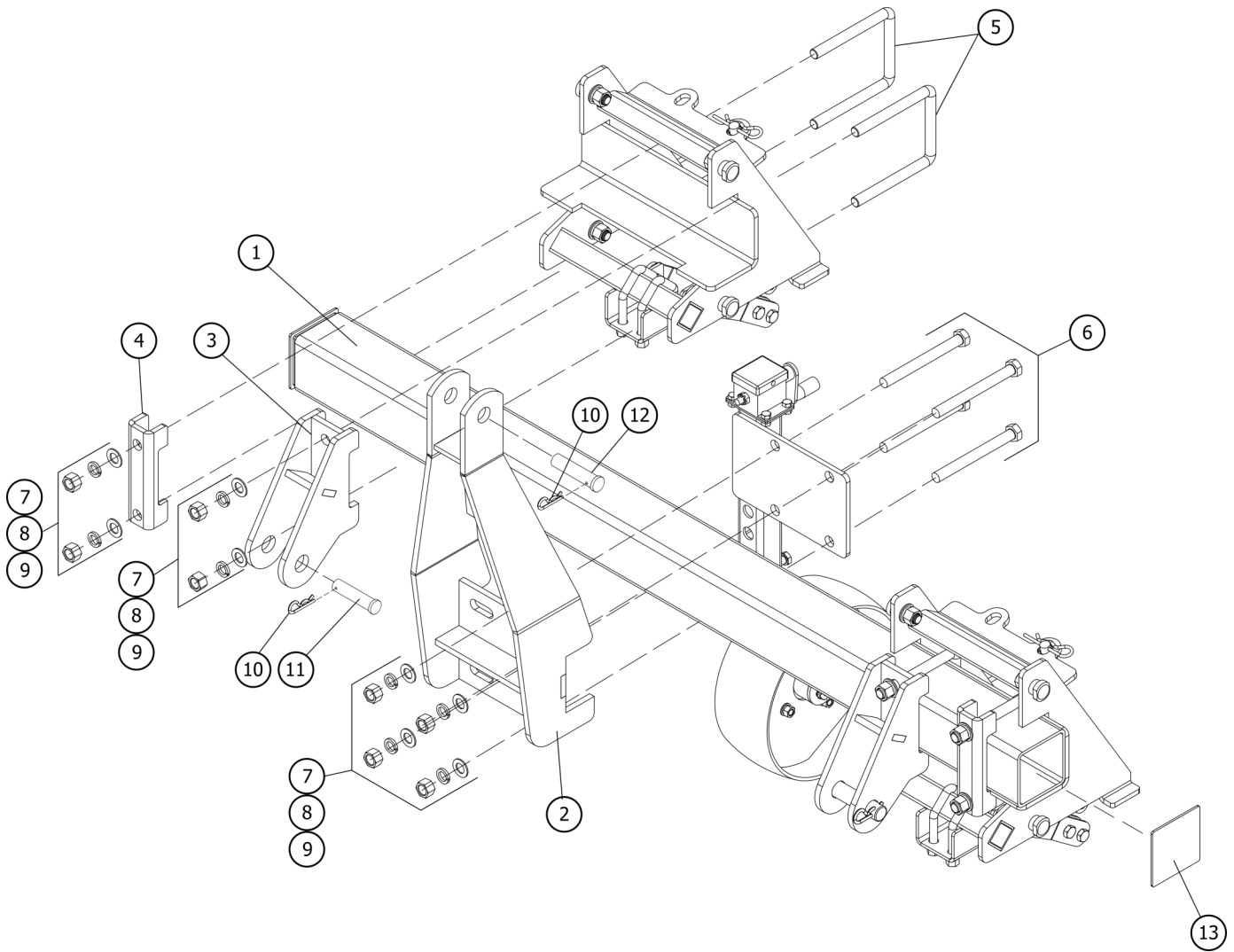

Main Frame - 2 Row

Item	Part #	Description	Qty.
1	CSP40014	Main beam 2 row CSP	1
2	CSP40012	Hitch, upper CSP	1
3	CSP40013	Hitch, lower CSP	2
4	CSP40027	U-bolt reinforcement	2
5	CSP40022	U-bolt lower hitch CSP	2
6	BM1620160	Bolt HH M16-2.0x160	2
7	NM1620	Nut HH M16-2.0	8
8	LW16	Washer lock M16	8
9	FW16	Washer flat M16	8
10	RC4	R-clip 4	3
11	CSP40023	Pin lower hitch CSP	2
12	CSP40024	Pin upper hitch CSP	1
13	CSP40017	End cap main beam CSP	2

Main Frame - 4 Row

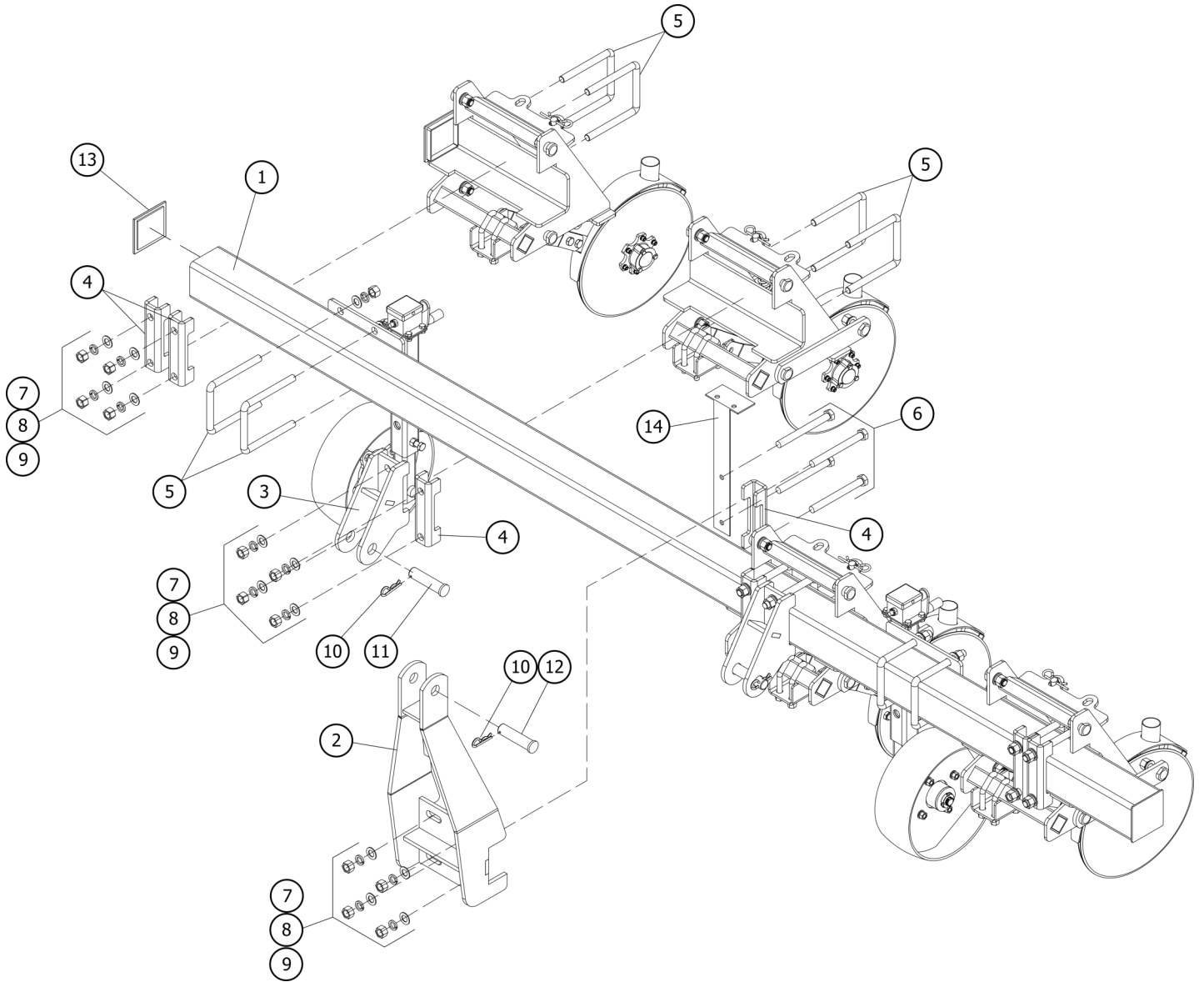

Main Frame - 4 Row

Item	Part #	Description	Qty.
1	CSP40028	Main beam 4 row CSP	1
2	CSP40012	Hitch, upper CSP	1
3	CSP40013	Hitch, lower CSP	2
4	CSP40027	U-bolt reinforcement	7
5	CSP40022	U-bolt lower hitch CSP	12
6	BM1620160	Bolt HH M16-2.0x160	4
7	NM1620	Nut HH M16-2.0	20
8	LW16	Washer lock M16	20
9	FW16	Washer flat M16	20
10	RC4	R-clip 4	3
11	CSP40023	Pin lower hitch CSP	2
12	CSP40024	Pin upper hitch CSP	1
13	CSP40017	End cap main beam CSP	2
14	CSP40029	Hydraulic block mount	1

Depth Limit Roller

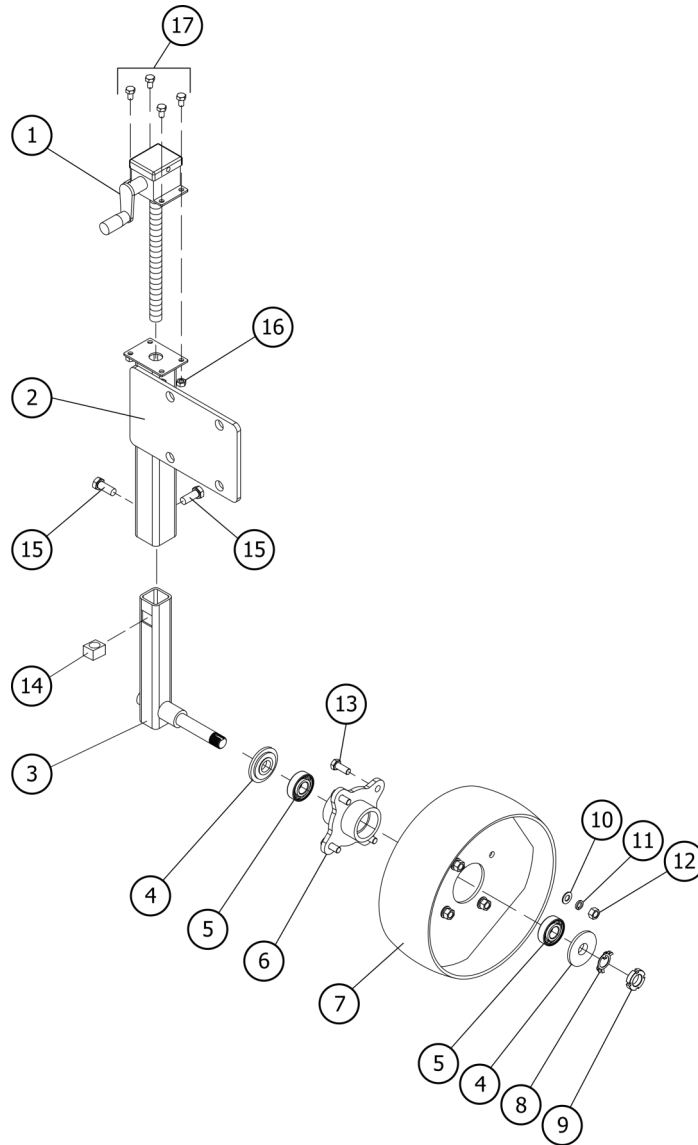

Depth Limit Roller

Item	Part #	Description	Qty.
1	CSP40025	Gauge wheel crank	1
2	CSP40015	Gauge wheel mount	1
3	CSP40016	Gauge wheel axle	1
4	CSP40018	Guage wheel bearing end cap	2
5	B6204-2RS	6204-2RS Bearing w/ Rubber Seals	2
6	CSP40019	Guage wheel hub	1
7	CSP40020	Guage wheel	1
8	CSP40021	Washer w/tabs M20	1
9	SNM2015	Spanner Nut M20 x 1.5	1
10	FW10	Washer flat M10	4
11	LW10	Washer lock M10	4
12	NM10125	Nut HH M10-1.5	4
13	BM1012525	Bolt HH M10-1.5x25	4
14	CSP40026	Crank nut	1
15	BM1212530	Bolt HH M12-1.5x30	2
16	NM08125	Nut HH M08-1.25	4
17	BM0812515	Bolt HH M08-1.25x15	4

Front Disc Opener

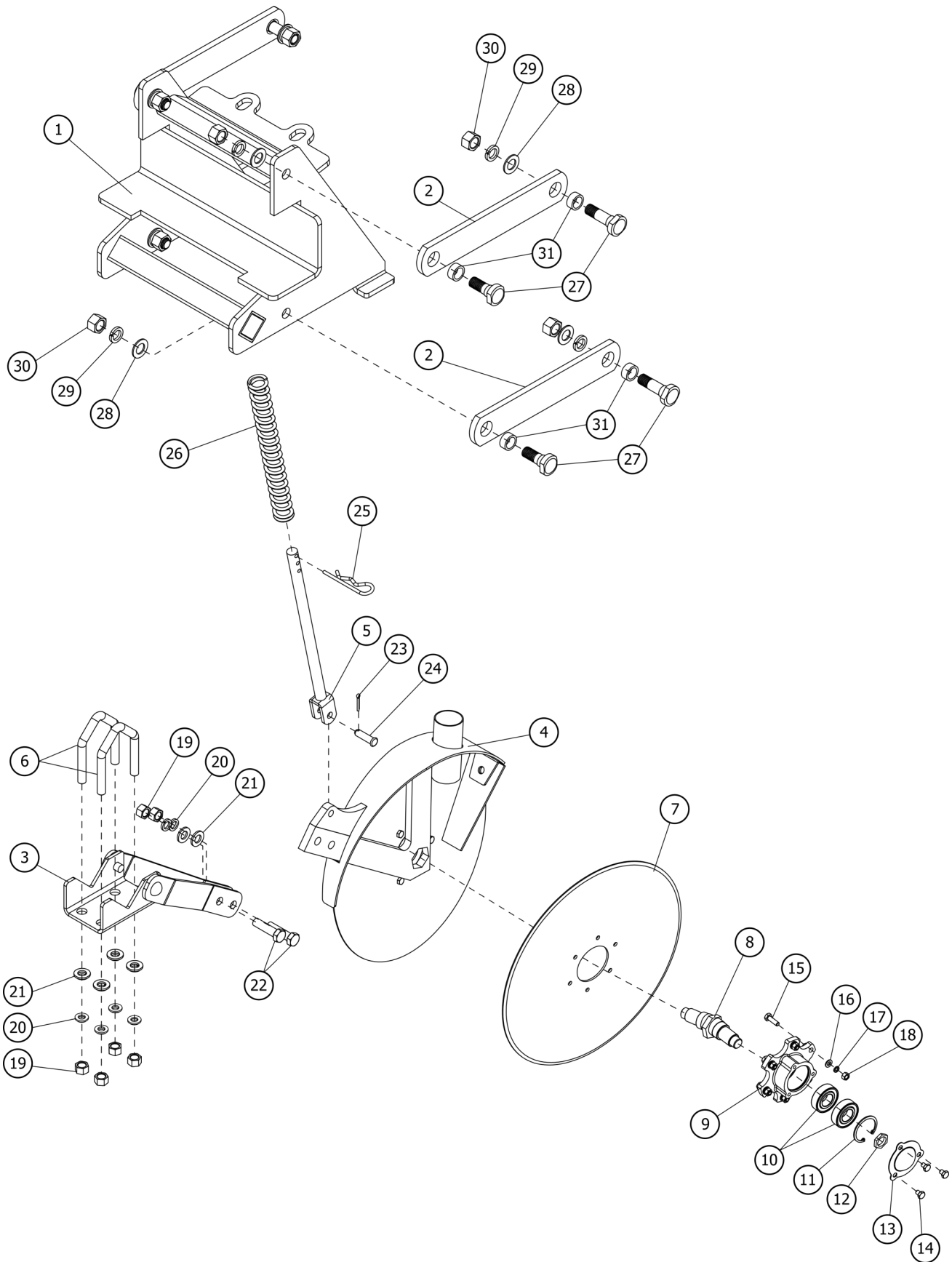

Front Disc Opener

Item	Part #	Description	Qty.
1	CSP40045	Front support mount	1
2	CSP40046	Front support linkage	4
3	CSP40047	Disc opener support bracket	1
4	CSP40048	Disc opener support mount	1
5	CSP40049	Damper rod	1
6	CSP40022	U-bolt lower hitch CSP	2
7	SA6004	Opener disc	2
8	CSP40050	Disc opener stud	1
9	SA6005	Disc support bearing	2
10	B60042RS	Bearing 6004 2RS	4
11	SRI-45	Snap ring - internal - M45	2
12	NM1620L	Nut HH M16-2.0 <i>LH thread</i>	
	NM1620	Nut HH M16-2.0 <i>RH thread</i>	
13	SA6009	Bearing grease cap	2
14	BM061008	Bolt HH M06-1.0x08	6
15	BM061020	Bolt HH M06-1.0x20	12
16	FW06	Washer flat M06	12
17	LW06	Washer lock M06	12
18	NM0610	Nut HH M06-1.0	12
19	NM1215	Nut HH M12-1.5	8
20	LW12	Washer lock M12	8
21	FW12	Washer flat M12	8
22	BM121545	Bolt HH M12-1.5x45	2
23	SA4010	Clevis pin M10x35	1
24	CP3x35	Cotter pin M5x40	1
25	RC4	R-clip M4	1
26	CSP40051	Damper rod spring	1
27	CSP40008	Shoulder bolt support linkage M16-2.0	8
28	FW16	Washer flat M16	8
29	LW16	Washer lock M16	8
30	NM1620	Nut HH M16-2.0	8
31	CSP40053	Front support linkage bushing	8

Rear Disc Opener

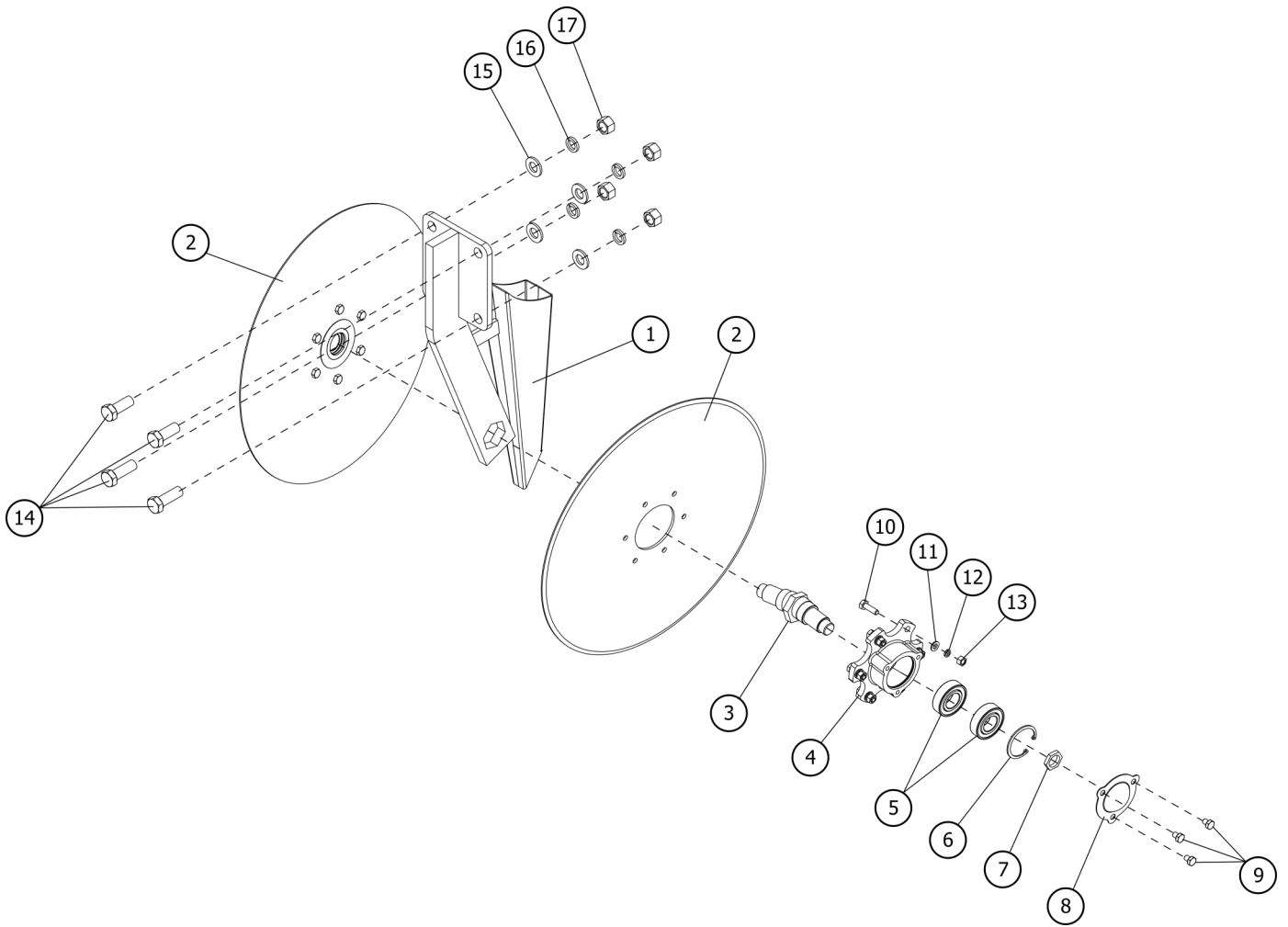

Rear Disc Opener

Item	Part #	Description	Qty.
1	CSP40054	Rear disc opener mount	2
2	SA6004	Opener disc	2
3	CSP40050	Disc opener stud	1
4	SA6005	Disc opener hub	2
5	B60042RS	Bearing 6004 2RS	4
6	SRI-45	Snap ring - internal - M45	2
7	NM1620L	Nut HH M16-2.0 <i>LH thread</i>	1
	NM1620	Nut HH M16-2.0 <i>RH thread</i>	1
8	SA6009	Bearing grease cap	2
9	BM061008	Bolt HH M06-1.0x08	6
10	BM061020	Bolt HH M06-1.0x20	12
11	FW06	Washer flat M06	12
12	LW06	Washer lock M06	12
13	NM0610	Nut HH M06-1.0	12
14	BM121535 FT 8.8	Bolt HH M12-1.5x35 full thread 8.8	4
15	FW12	Washer flat M12	4
16	LW12	Washer lock M12	4
17	NM1215	Nut HH M12-1.5	4

Drive Roller

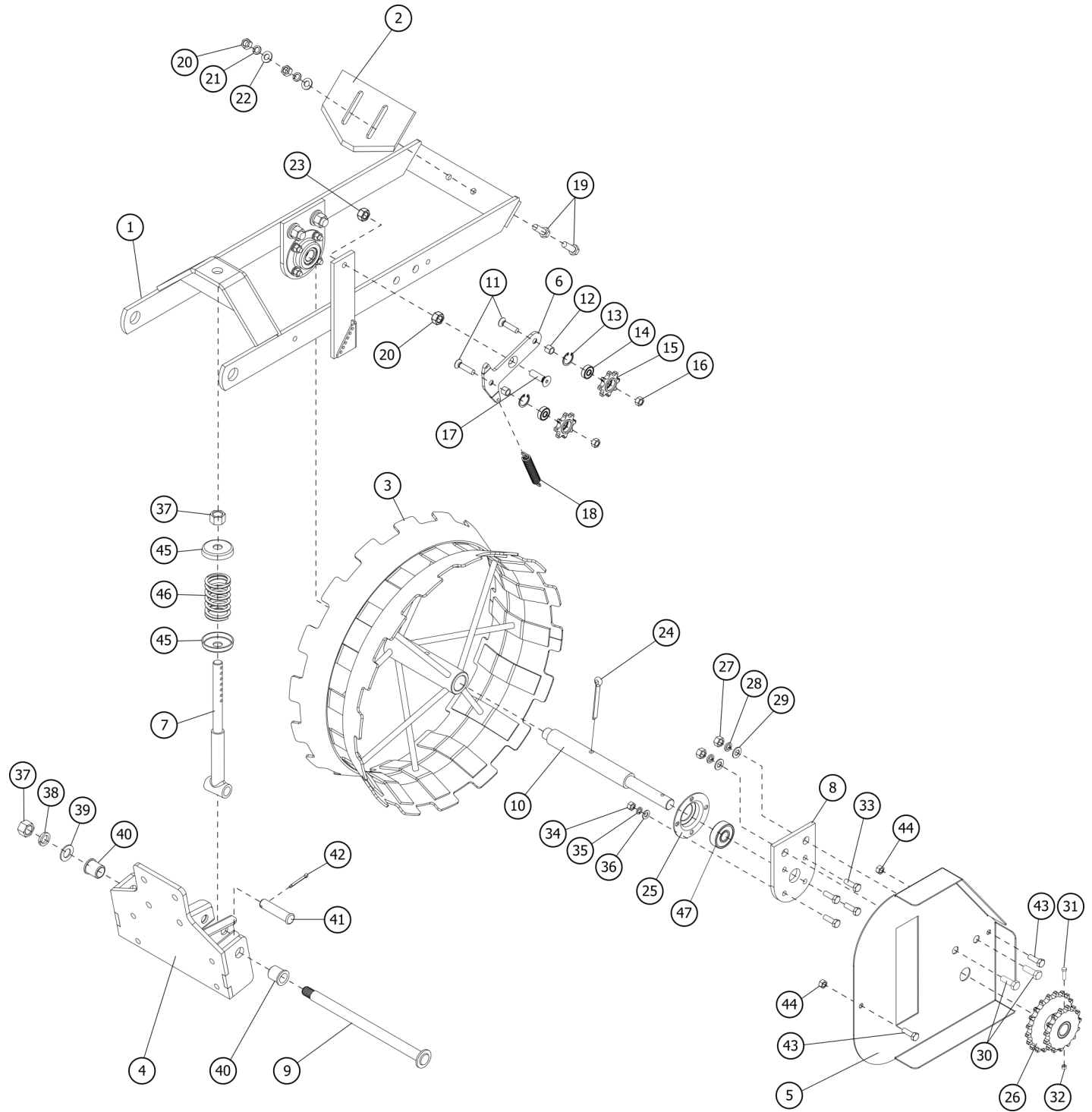

Drive Roller

Item	Part #	Description	Qty.
1	CSP40055	Drive roller support	1
2	CSP40056	Drive roller scraper	1
3	CSP40057	Drive roller	1
4	CSP40058	Drive roller link plate	1
5	CSP40059	Drive roller shield	1
6	CSP40004	Idler arm CSP	1
7	CSP40060	Spring rod	1
8	CSP40061	Drive roller bearing mount	2
9	CSP40062	Drive roller connecting screw	1
10	CSP40063	Drive roller axle	1
11	SSM0812535	Hex drive flat head screw M08-1.25x35	2
12	CSP40064	Idler spacer, drive roller	2
13	SR122	Snap ring - internal M22	2
14	B6082RS	Bearing 608 2RS	2
15	CSP40065	Idler sprocket, drive roller	2
16	LN08125	Nut HH locking M08-1.25	1
17	SSM101530	Hex drive flat head screw M10-1.5x30	1
18	CSP40011	Idler spring	1
19	BM101530	Bolt HH M10-1.5x30	2
20	NM1015	Nut HH M10-1.5	2
21	LW10	Washer lock M10	2
22	FW10	Washer flat M10	2
23	LN081015	Nut HH locking M10-1.5	1
24	CSP40066	Split pin M08x60	1
25	CSP40067	Bearing hub drive roller	2
26	CSP40068	Sprocket drive roller	1
27	NM1415	Nut HH M14-1.5	4
28	LW14	Washer lock M14	4
29	FW14	Washer flat M14	4
30	BM141540	Bolt HH M14-1.5x40	4
31	BM061040	Bolt HH M06-1.0x40	1
32	LN0610	Nut HH self-locking M06-1.0	1
33	BM0812525	Bolt HH M08-1.25x25	8
34	NM08125	Nut HH M08-1.25	8
35	LW08	Washer lock M08	8
36	FW08	Washer flat M08	8
37	NM1615	Nut HH M16-1.5	1
38	LW16	Washer lock M16	1
39	FW16	Washer flat M16	1

Drive Roller

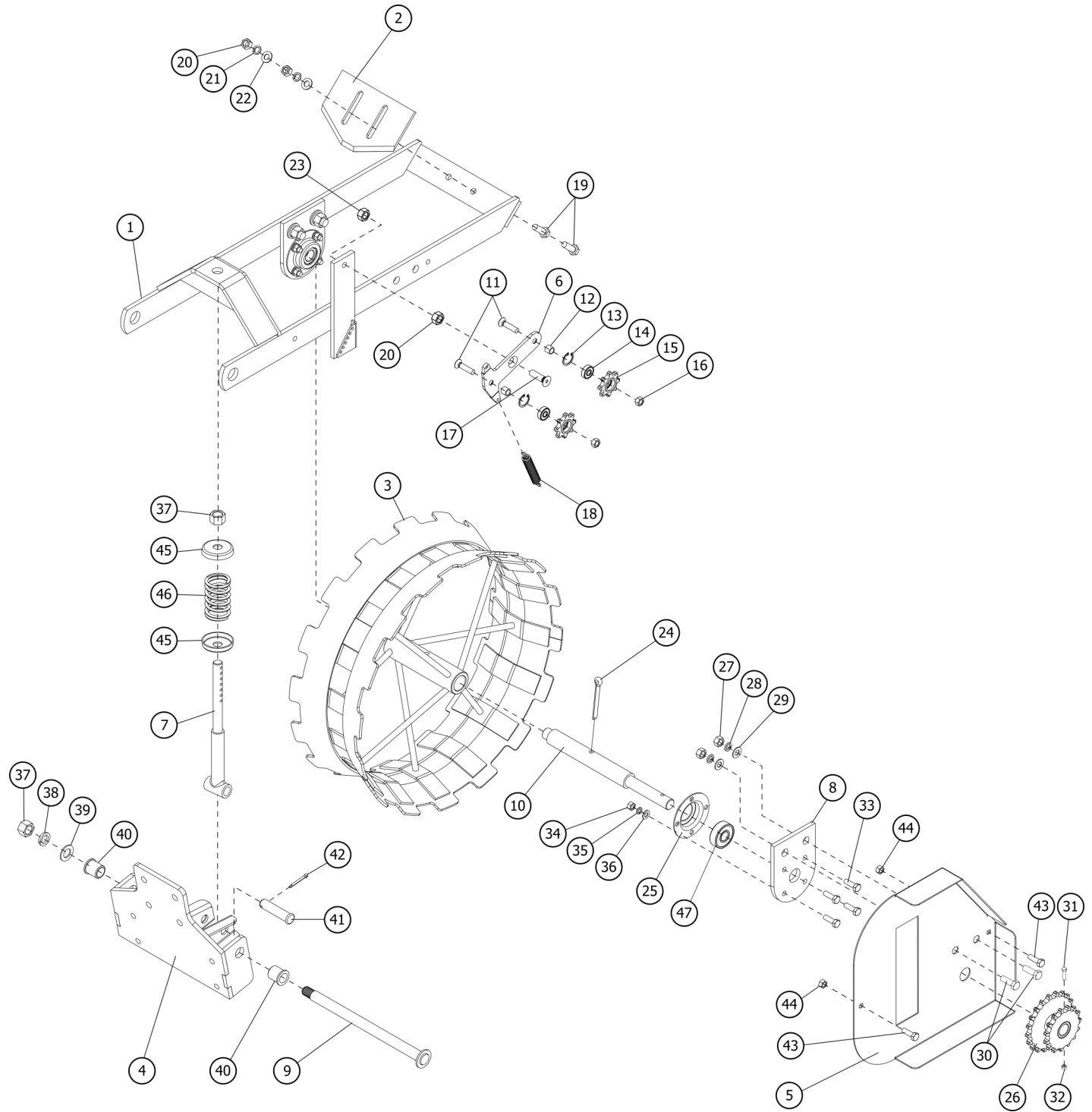

Drive Roller

Item	Part #	Description	Qty.
40	CSP40069	Nylon sleeve	2
41	CSP40070	Clevis pin M16x65	1
42	CSP40071	Split pin M04x32	1
43	FBM0812520	Flange bolt M08-1.25x20	2
44	FNM08125	Flange nut M08-1.25	2
45	CSP40072	Spring end cap	2
46	CSP40073	Drive roller spring	1
47	B6204 2RS	Bearing 6204 2RS	2

Front Hopper

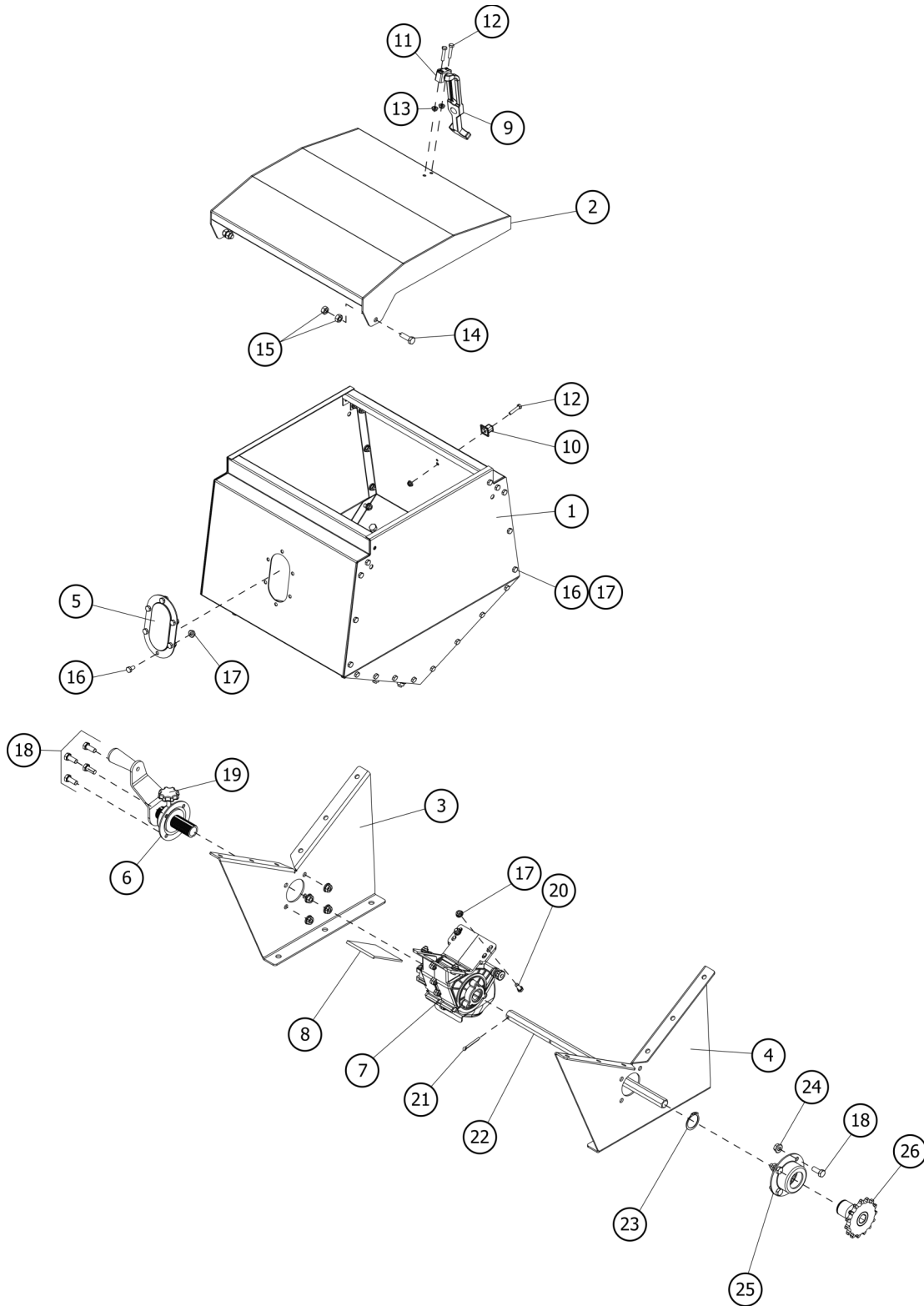

Front Hopper

Item	Part #	Description	Qty.
1	CSP40074	Front hopper CSP	1
2	CSP40075	Front hopper CSP	1
3	CSP40076	Front hopper CSP - RH base	1
4	CSP40077	Front hopper CSP - LH base	1
5	CSP40078	Observation window	1
6	DL2005	Adjustment handle	1
7	CSP40079	Seed cup, front hopper CSP	1
8	SA4199	Shut off flap	1
9	SA4063	Hopper lid strap	1
10	SA4065	Hopper lid strap latch	1
11	SA4064	Hopper lid strap retainer	1
12	BM040725	Bolt HH M04-0.7x25	3
13	FNM0407	Nut flange HH M04-0.7	3
14	BM0812525	Bolt HH M08-1.25x25	2
15	NM08125	Nut HH M08-1.25	4
16	BM061012	Bolt HH M06-1.0x12	-
17	NM0610	Nut HH M06-1.0	-
18	BM0812520	Bolt HH M08-1.25x20	8
19	FW20	Washer flat M20	1
20	BM061016	Bolt HH M06-1.0x16	4
21	CSP40080	Split pin M4x32	1
22	CSP40081	Hex shaft, front hopper	1
23	SRI30	Snap ring - Internal - M30	1
24	FNM08125	Flange nut M8-1.25	4
25	DL1005	Flange assembly w/bearing	1
26	CSP40082	Sprocket 15T, front hopper	1

Rear Hopper

Item	Part #	Description	Qty.
1	CSP40084	Rear hopper CSP	1
2	CSP40085	Rear hopper lid CSP	1
3	CSP40089	Gearbox CSP	1
4	CSP40086	Rear hopper gear CSP	1
5	CSP40087	Hinge plate LH	1
6	CSP40088	Hinge plate RH	1
7	SA4063	Hopper lid strap	1
8	SA4064	Hopper lid strap retainer	1
9	BM040725	Bolt HH M04-0.7x25	3
10	FNM0407	Nut flange M04-0.7	3
11	SA4065	Hopper lid strap latch	1
12	BM0812520	Bolt HH M08-1.25x20	2
13	NM08125	Nut HH M08-1.25	2
14	BM061012	Bolt HH M06-1.0x12	4
15	NM0610	Nut HH M06-1.0	4
16	BM061030	Bolt HH M06-1.0x30	1

Row Marker

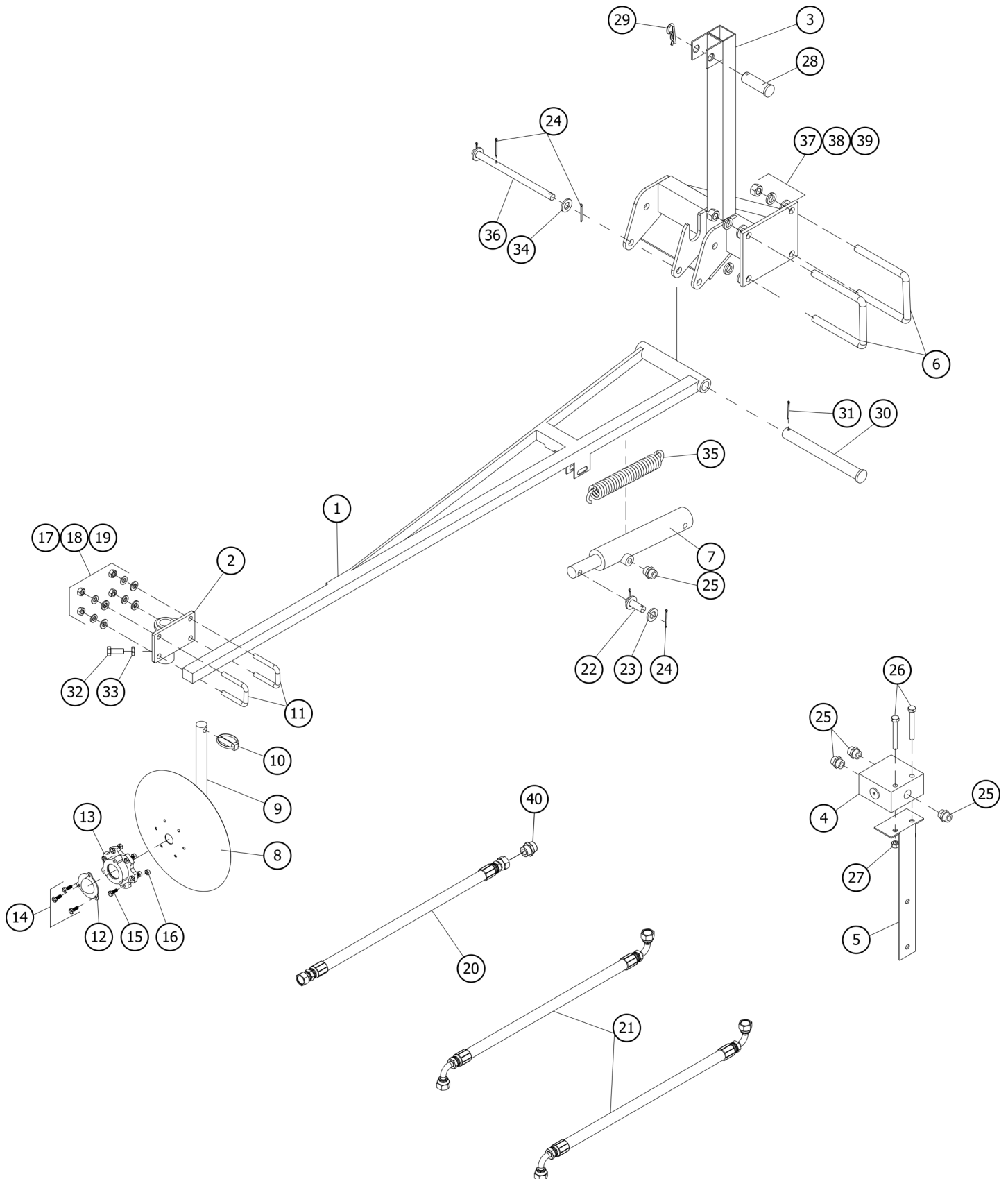

Row Marker

Item	Part #	Description	Qty.
1	CSP40030	Row marker boom LH	1
	CSP40091	Row marker boom RH	1
2	CSP40031	Row marker disc mount	2
3	CSP40032	Row marker boom mount LH	1
	CSP40092	Row marker boom mount RH	1
4	CSP40033	Hydraulic block CSP	1
5	CSP40029	Hydraulic block mount	1
6	CSP40022	U-bolt lower hitch CSP	4
7	CSP40034	Hydraulic cylinder CSP	2
8	CSP40035	Row marker disc	2
9	CSP40036	Disc axle CSP	2
10	DLYNPN08	Lynch pin	2
11	CSP40037	U-bolt, disc mount	2
12	SA6009	Bearing grease cap	2
13	SA6005	Disc support bearing	2
14	BM061012	Bolt HH M06-1.0x12	6
15	BM061025	Bolt HH M06-1.0x25	12
16	NM0610	Nut HH M06-1.0	12
17	NM1620	Nut HH M16-2.0	8
18	LW16	Washer lock M16	8
19	FW16	Washer flat M16	8
20	CSP40039	Hydraulic hose, supply CSP	1
21	CSP40038	Hydraulic hose, cylinder CSP	2
22	CSP40040	Pin Ø15x72	2
23	LFW16	Large flat washer M16	4
24	CP3x35	Cotter pin 3x35	8
25	CSP40041	Hydraulic adaptor CSP	4
26	BM101580	Bolt HH M10-1.5x80	2
27	NM1015	Nut HH M10-1.5	2
28	SA4131	Clevis pin M10x65	2
29	RC3	R clip 3.5	2
30	CSP40042	Boom pin, row marker	2
31	CP5x45	Cotter pin M5x45	2
32	BM1217530FT	Bolt HH M12-1.75x30 full thread	4
33	NM12175	Nut HH M12-1.75	4
34	FW16	Washer flat M16	4
35	CSP40043	Spring, row marker CSP	2
36	CSP40044	Pin Ø15x250	2
37	NM1620	Nut HH M16-2.0	8
38	LW16	Washer lock M16	8
39	FW16	Washer flat M16	8
40	CSP40090	Hydraulic adaptor M20-1.5 male x 1/2" NPT male	1

Decals

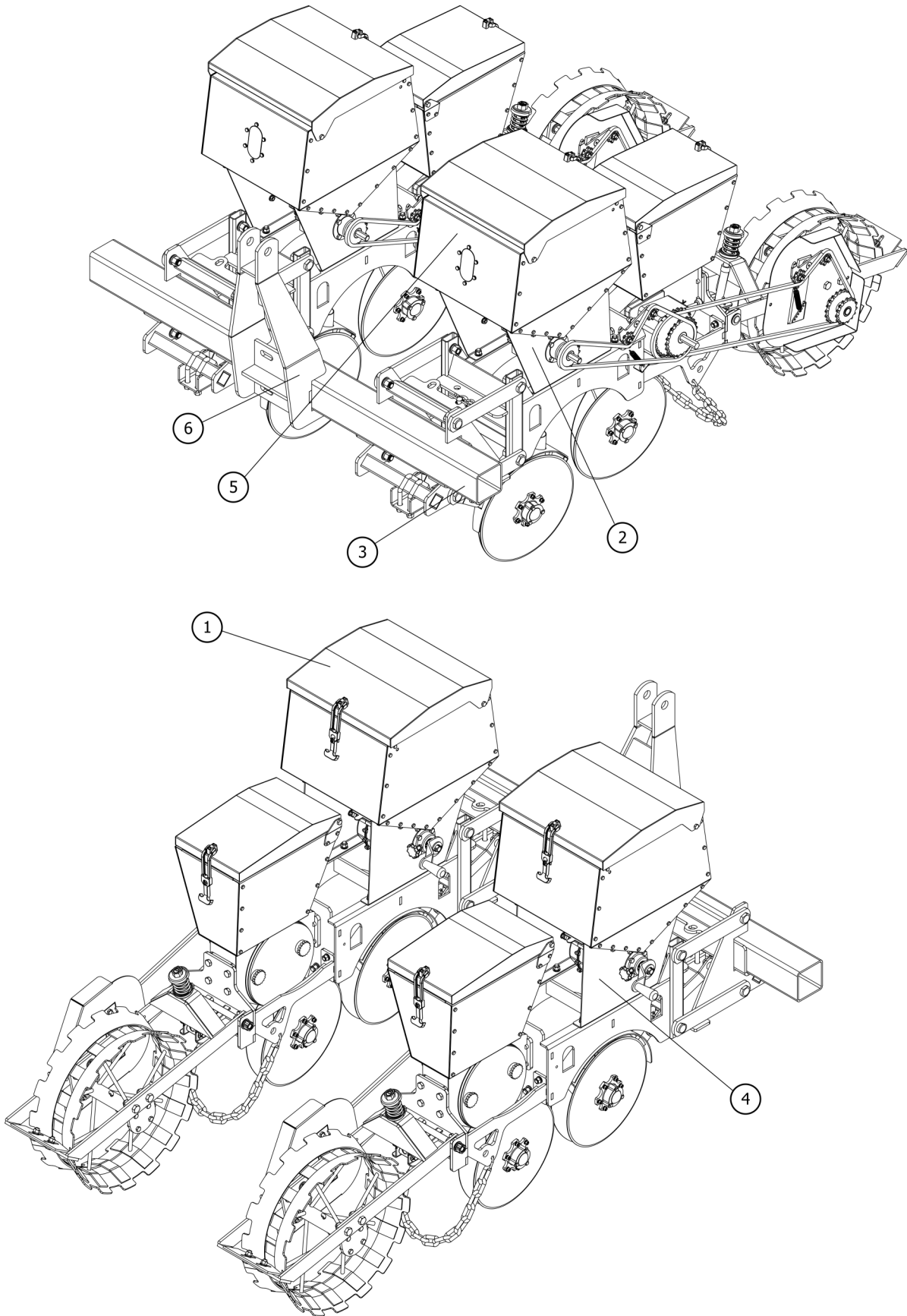

Decals

Item	Part #	Description	Qty.
1	5SBD1004	Decal Warning "Chemicals" (Located inside lid - front hopper)	2/4
2	D1348	Decal Danger Prevent Serious Injury - Chain	2/4
3	D1350	Decal Caution Read Operator's Manual 3x3	1
4	D1316	Decal Adjustment Handle	2/4
5	CSP-2R	Decal Model # 2 Row Corn Planter	1
	CSP-4R	Decal Model # 4 Row Corn Planter	1
6	-	Decal Serial Tag	1

Warranty

LIMITED WARRANTY

Belco Resources Equipment warrants to the original purchaser of any new piece of machinery from Belco Resources Equipment, purchased from an authorized Belco Resources Equipment dealer, that the equipment be free from defects in material and workmanship for a period of one (1) year for non-commercial, state, and municipalities' use, ninety (90) days for commercial use from date of retail sale. Warranty for rental purposes is thirty (30) days. The obligation of Belco Resources Equipment to the purchaser under this warranty is limited to the repair or replacement of defective parts.

Replacement or repair parts installed in the equipment covered by this limited warranty are warranted for ninety (90) days from the date of purchase of such part or to the expiration of the applicable new equipment warranty period, whichever occurs later. Warranted parts shall be provided at no cost to the user at an authorized Belco Resources Equipment dealer during regular working hours. Belco Resources Equipment reserves the right to inspect any equipment or parts, which are claimed to have been defective in material or workmanship.

This limited warranty does not apply to and excludes wear items such as shear pins, tires, tubes knives, blades or other wear items. Oil or grease is not covered by this warranty.

All obligations of Belco Resources Equipment under this limited warranty shall be terminated if:

- Proper service is not performed on the machine.

- The machine is modified or altered in any way.

- The machine is being used or has been used for purposes other than those for which the machine was intended.

DISCLAIMER OF IMPLIED WARRANTIES & CONSEQUENTIAL DAMAGES

Belco Resources Equipment obligation under this limited warranty, to the extent allowed by law, is in lieu of all warranties, implied or expressed, including implied warranties of merchantability and fitness for a particular purpose and any liability for incidental and consequential damages with respect to the sale or use of the items warranted. Such incidental and consequential damages shall include but not be limited to: transportation charges other than normal freight charges; cost of installation other than cost approved by Belco Resources Equipment; duty; taxes; charges for normal service or adjustment; loss of crops or any other loss of income; rental of substitute equipment, expenses due to loss, damage, detention or delay in the delivery.

REGISTRATION

The online Warranty Registration must be completed in order to qualify for coverage on this Limited Warranty. Visit br-equipment.com, click on "Warranty Registration" and completely fill out the form to register the new piece of equipment.

Page left blank intentionally



401 Jeffreys Road
Rocky Mount, NC 27804
www.tarrivermfg.com

Tel: 252-822-7140
Fax: 252-787-5855
Sales@tarrivermfg.com