

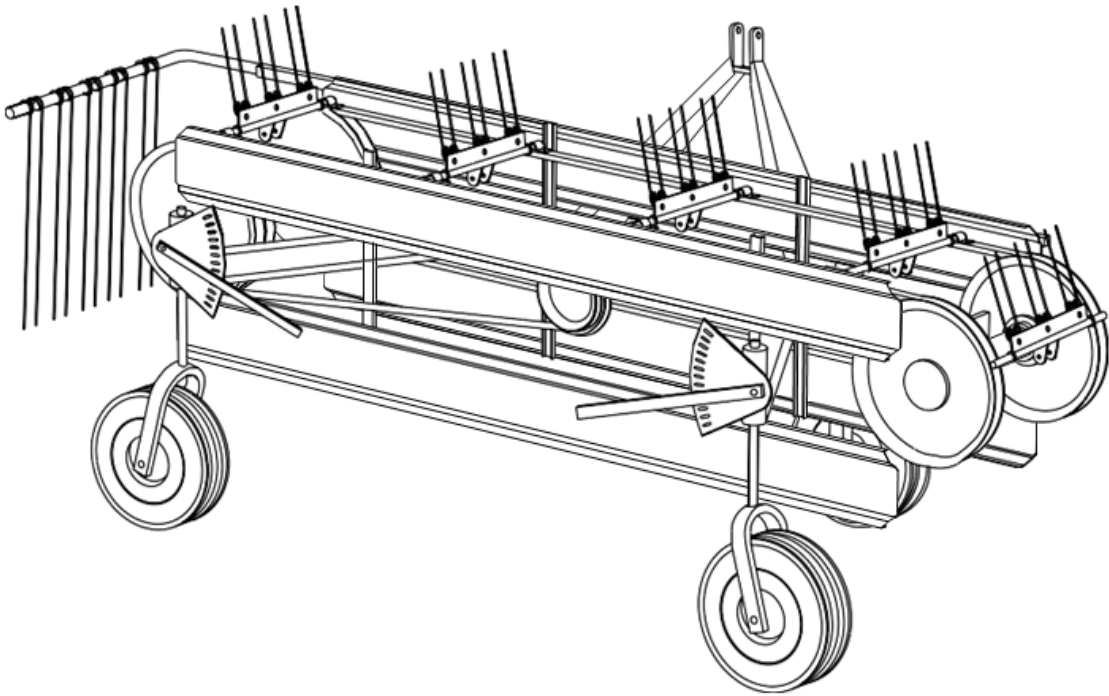

Belt Rake

D150, D180



Operator's Manual

Page left blank intentionally

TO THE DEALER:

Assembly and proper installation of this product is the responsibility of the Tar River dealer. Read manual instructions and safety rules. Make sure all items on the Dealer's Pre-Delivery and Delivery Check Lists in the Owner's/Operator's Manual are completed before releasing equipment to the owner.

TO THE OWNER:

Read this manual before operating your Tar River equipment. The information presented will prepare you to do a better and safer job. Keep this manual handy for ready reference. Require all operators to read this manual carefully and become acquainted with all the adjustment and operating procedures before attempting to operate. Replacement manuals can be obtained from your selling dealer. The equipment you have purchased has been carefully engineered and manufactured to provide dependable and satisfactory use. Like all mechanical products, it will require cleaning and upkeep. Lubricate the unit as specified. Observe all safety information in this manual and safety decals on the equipment. For service, your authorized Tar River dealer has trained mechanics, genuine Tar River service parts, and the necessary tools and equipment to handle all your needs. Use only genuine Tar River service parts. Substitute parts will void the warranty and may not meet standards required for safe and satisfactory operation.

Record your implement model and serial number in the space provide below. Your dealer will need this information to give you prompt, efficient service.

Model Number: _____

Serial Number: _____

Date Purchased: _____

Table of Contents

Introduction	5
Technical Specifications	5
Safety	6
Safety Signal Words	6
General Safety Guidelines	7
Safety Decal Care	7
Before Operation	8
During Operation	9
Highway And Transport Operations	11
Features	12
Attaching to Tractor.....	13
PTO Instructions	14
Adjusting Belt Rake	15
Periodic Maintenance	16
Lifting Belt Rake	16
Torque Specifications	17
Parts Breakdown	19-31
Warranty	32

Introduction

Thank you for purchasing your Belt Rake. The Belt Rake is an ideal hay tool for the small to medium sized hay producer. Great durability and low maintenance as well as simplicity are just a few benefits for this tedder-rake combination Belt Rake.

The D150 is a low profile design that can operate with any HP tractor. Simple and easy to use with very low maintenance. The 3 tines per row make clean sweep of your pasture. Fast adjustments allow one to go from tedding to raking in a breeze.

The D180 comes standard with 4 double tines per row and all the features of the D150. This extra set of times is helpful in heavier hay crop conditions.

Technical Specifications

- Heavy square tubing construction.
- Heavy duty belts for long life.
- Rear height adjustment wheels.

	D150	D180
Weight	408 lbs.	485 lbs.
Working width	71"	83"
# of belts	2	2
Tines x Crossbeam	3	4

Important Safety Information

Safety

It is important that you read the entire manual and to become familiar with this product before you begin using it. This product is designed for certain applications only. The manufacturer cannot be responsible for issues arising from modification. We strongly recommend this product not be modified and /or used for any application other than that for which it is designed. If you have any questions relative to a particular application, DO NOT use the product until you have first contacted us to determine if it can or should be performed on the product.

Read and understand this manual and all safety signs before operating and maintaining . Review the safety instructions and precautions annually.

Safety Signal Words

TAKE NOTE! This safety alert symbol found though out this manual is used to call you attention to instructions involving you personal safety and the safety of others. Failure to follow these instructions can result in injury or death.



**This symbol means:
Attention!
Become alert!
Your safety is involved!**

Note the use of the signal words, DANGER, WARNING and CAUTION with the safety messages. The appropriate signal word for each has been selected using the following guidelines:



DANGER: Indicates an imminently hazardous situation that, if not avoided, will result in death or serious injury. This signal word is to be limited to the most extreme situations typically for machine components which, for functional purposes, cannot be guarded.



WARNING: Indicates a potentially hazardous situation that, if not avoided, could result in death or serious injury, and includes hazards that are exposed when guards are removed. It may also be used to alert against unsafe practices.



CAUTION: Indicates a potentially hazardous situation that, if not avoided, may result in minor or moderate injury. It may also be used to alert against unsafe practices.

Important Safety Information

General Safety Guidelines

Safety of the operator is one of the main concerns in designing and developing a new piece of equipment. Designers and manufacturers build in as many safety features as possible. However, every year many accidents occur which could have been avoided by a few seconds of thought and a more careful approach to handling equipment. You, the operator, can avoid many accidents by observing the following precautions in this section. To avoid personal injury, study the following precautions and insist those working with you, or for you, follow them.

Replace any DANGER, WARNING, CAUTION or instruction safety decal that is not readable or is missing. Location of such decals are indicated in this manual. Do not attempt to operate this equipment under the influence of drugs or alcohol.

Review the safety instructions with all users annually.

This equipment is dangerous to children and persons unfamiliar with its operation. The operator should be a responsible adult familiar with farm machinery and trained in this equipment's operations. **Do not allow persons to operate or assemble this unit until they have read this manual and have developed a thorough understanding of the safety precautions and of how it works.**

To prevent injury of death, use a tractor equipped with a Roll Over Protection System (ROPS). Do not paint over, remove or deface any signs or warning decals on your equipment. Observe all safety signs and practice the instructions on them.

Never exceed the limits of a piece of machinery. If its ability to do a job, or to do so safely, is in question - **Don't try it!**



Safety Decal Care

- Keep safety signs clean and legible at all times.
- Replace safety signs that are missing or have become illegible.
- Replaced parts that displayed a safety sign should also display the current safety sign
- Safety signs are available from your Distributor or Dealer Parts Department or the factory.

Important Safety Information

How to install Safety Signs:

- Be sure that the installation area is clean and dry.
- Decide on the exact position before you remove the backing paper.
- Remove the smallest portion of the split backing paper.
- Align the decal over the specified area and carefully press the small portion with the exposed sticky backing in place.
- Slowly peel back the remaining paper and carefully smooth the remaining portion of the decal in place.
- Small air pockets can be pierced with a pin and smoothed out using the piece of decal backing paper.



Before Operation

- Carefully study and understand this manual.
- Do not wear loose-fitting clothing, which may catch in moving parts.
- Always wear protective clothing and substantial shoes.
- Assure that all tires are inflated evenly.
- Give the unit a visual inspection for any loose bolts, worn parts or cracked welds, and make necessary repairs. Follow the maintenance safety instructions included with this manual.
- Be sure that there are no tools lying on or in the equipment.
- Do not use the unit until you are sure that the area is clear, especially of children and animals.
- Don't hurry the learning process or take the unit for granted. Ease into it and become familiar with your new equipment.
- Practice operation of your equipment and its attachments. Completely familiarize yourself and other operators with its operation before using.
- Use a tractor equipped with a Roll Over Protection System (ROPS) and fasten your seat belt prior to starting engine.
- The manufacturer does not recommend usage of tractor with ROPS removed.
- Move tractor wheels to the widest recommended settings to increase stability.
- Securely attach to towing unit. Use a high strength, appropriately sized hitch pin with a mechanical retainer and attach safety chain.
- Do not allow anyone to stand between the tongue or hitch and the towing vehicle when backing up to the equipment.
- Do not use the unit until you are sure that the area is clear, especially of children and animals.

Important Safety Information



During Operation

- Children should not be allowed on the product.
- Clear the area of small children and bystanders before moving the implement.
- If using a towing unit, securely attach implement by using a hardened 3/4" pin, a metal retainer, and safety chains if required. Shift towing unit to a lower gear before going down steep downgrades, thus using the engine as a retarding force. Keep towing vehicle in gear at all times. Slow down for corners and rough terrain.
- Make sure you are in compliance with all local and state regulations regarding transporting equipment on public roads and highways. Lights and slow moving signs must be clean and visible by overtaking or oncoming traffic when implement is transported.
- Beware of bystanders, **particularly children!** Always look around to make sure that it is safe to start the engine of the towing vehicle or move the unit. This is particularly important with higher noise levels and quiet cabs, as you may not hear people shouting.
- **NO PASSENGERS ALLOWED!** Do not carry passengers anywhere on, or in, the tractor or equipment, except as required for operation.
- Keep hands and clothing clear of moving parts.
- Do not clean, lubricate or adjust your equipment while it is moving.
- When halting operation, even periodically, set the tractor or towing vehicle brakes, disengage the PTO, shut off the engine and **remove the ignition key.**
- Be especially observant of the operating area and terrain. Watch for holes, rocks or hidden hazards. Always inspect the area prior to operation.
- **DO NOT** operate near the edge of drop-offs or banks.
- **DO NOT** operate on steep slopes as overturns may result.
- Operate up and down (not across) intermediate slopes. Avoid sudden starts and stops.

Important Safety Information



Highway and Transport Operations

- Adopt safe driving practices.
- Keep the brake pedals latched together at all times. **Never use independent braking with machine in tow as loss of control and/or upset of unit can result.**
- Always drive at a safe speed relative to local conditions and ensure that your speed is low enough for an emergency stop to be safe and secure. Keep speed at a minimum.
- Reduce speed prior to turns to avoid the risk of overturning.
- Avoid sudden uphill turns on steep slopes.
- Always keep the tractor or towing vehicle in gear to provide engine braking when going downhill. Do not coast.
- Do not drink and drive!
- Comply with state and local laws governing highway safety and movement of farm machinery on public roads.
- Use approved accessory lighting flags and necessary warning devices to protect operators of other vehicles on the highway during daylight and nighttime transport. Various safety lights and devices are available from your dealer.
- The use of flashing amber lights is acceptable in most localities. However, some localities prohibit their use. Local laws should be checked for all highway and marking requirements.
- When driving the tractor and equipment on the road or highway under 40 kph (20 mph) at night or during the day, use the amber warning lights and a slow moving vehicle (SMV) identification emblem.
- Plan your route to avoid heavy traffic.
- Be a safe and courteous driver. Always yield to oncoming traffic in all situations, including narrow bridges, intersections, etc.
- Be observant of bridge loading ratings. Do not cross bridges rated at lower than the gross weight at which you are operating.
- Watch for obstructions overhead and to the side while transporting.
- Always operate in a position to provide maximum visibility at all times. Make allowances for increased length and weight of the equipment when making turns, stopping the unit, etc.
- Pick the most level route when transporting across fields. Avoid the edges of ditches or gullies and steep hillsides.
- Be extra careful when working in inclines.

Important Safety Information



Highway and Transport Operations

- Maneuver the tractor or towing vehicle at safe speeds.
- Avoid overhead wires or other obstacles. Contact with overhead lines could cause serious injury or death.
- Avoid loose fill, rocks and holes, they can be dangerous for equipment operation or movement.
- Allow for unit length when making turns,
- Operate the towing vehicle from the operator's seat only.
- Never stand alongside of unit with engine running or attempt to start engine and/or operate machine while standing alongside of unit.
- Never leave running equipment attachments unattended.
- As a precaution, always recheck the hardware on equipment following every 100 hours of operation. Correct all problems. Follow the maintenance safety procedures.

Overall dimensions for transport 'width x height':

D150 - 72" x 55"

D180 - 84" x 55"

Features

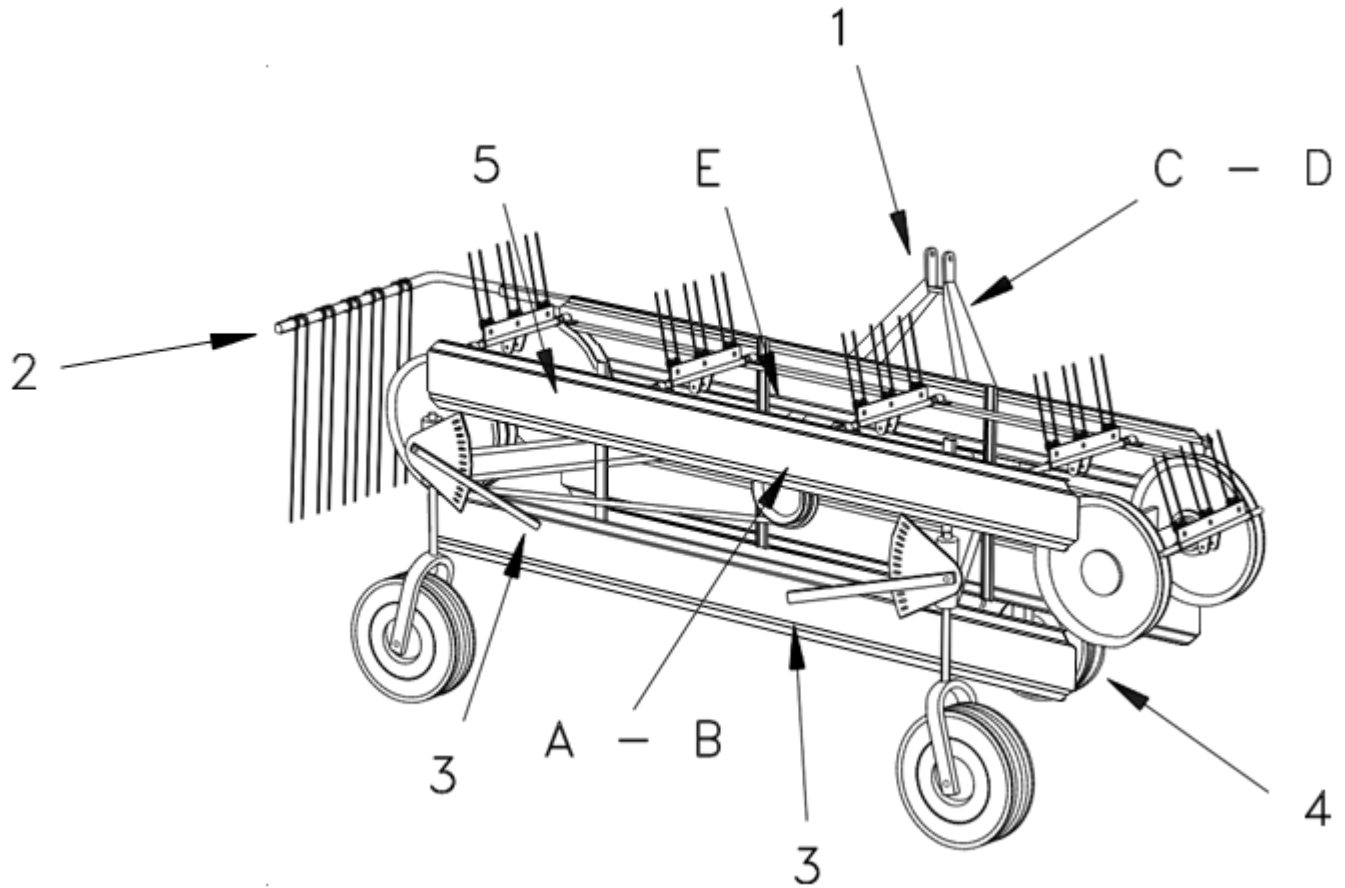

1. Three Point Linkage, 2. Hay Stopper, 3. Adjustment Bar, 4. Third Wheel, 5. Guards

Attaching to Tractor

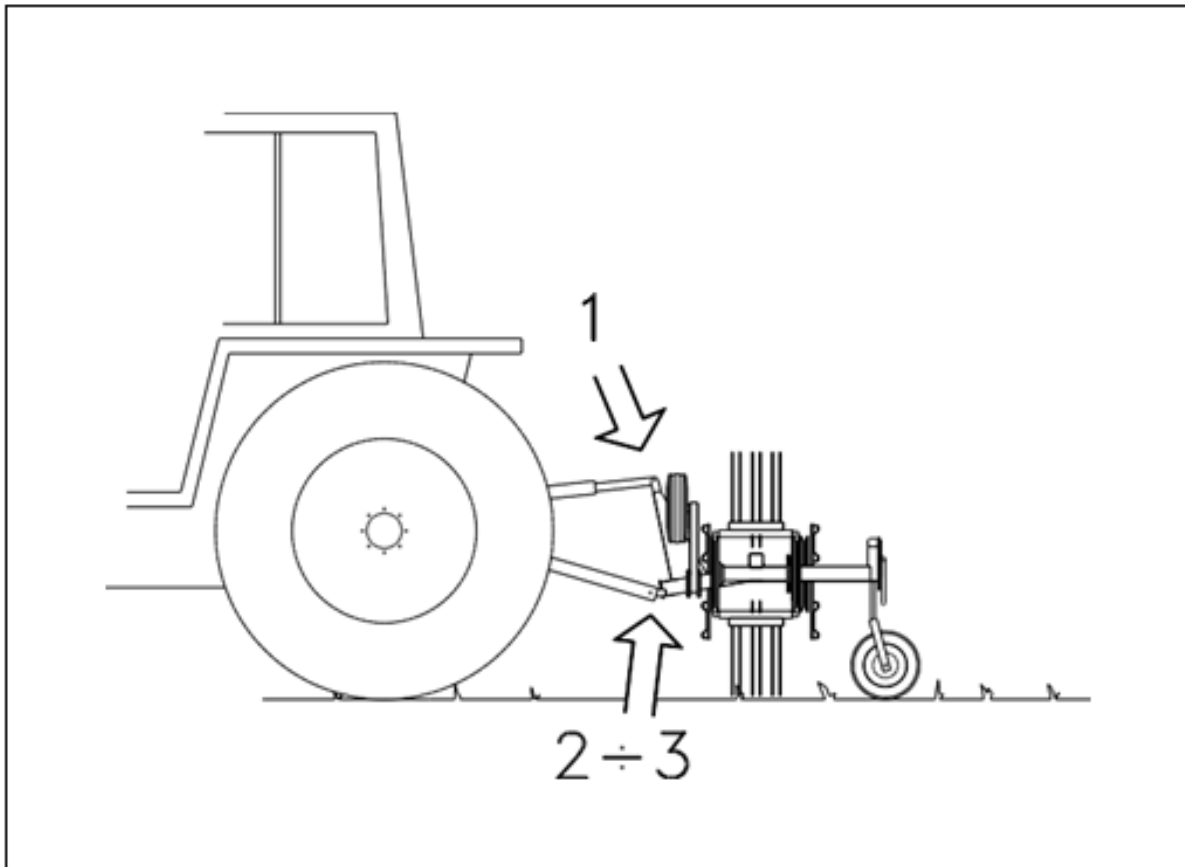

Carry out this operation on a flat surface.

Don't forget to shut the tractor down every time. Coupling must be done as shown in the above picture. Remember to lock the three points with the special spring pins provided with safety devices. After coupling remember to raise the third wheel upwards.

Attaching PTO Shaft

Before installing the PTO shaft make sure that the RPM rating and the direction of rotation match those of the tractor. Carefully read the PTO shaft and tractor instructions. Before operation, make sure that the guards are installed on the power take off of the tractor and PTO shaft. Make sure that they cover the PTO shaft throughout its length. Note: The PTO shaft may be too long and require shortening. See “**Shortening a PTO driveline**” below.

Press the locking pin on the PTO yoke and slide yoke on to the PTO of the tractor until the pin seats. Pull on PTO shaft to make certain it is locked in place. Repeat the procedure for the machine end. Attach the PTO cover’s safety chains to a stationary part of the tractor. Leave some slack in the chain to accommodate movement.

Shortening a PTO driveline

1. With the machine attached to the tractor’s 3-point hitch, and the PTO shaft not installed, separate the PTO shaft. Attach the machine end to the machine and the other end to the tractor PTO input shaft.
2. Raise the machine by using the tractor’s hydraulic 3-point hitch to its maximum lift height.
3. Hold the half shafts next to each other and mark them so each end is approximately 1/2” from hitting the end of the telescopic profiles.
4. Shorten the inner and outer guard tubes equally.
5. Shorten the inner and outer profiles by the same length as the guard tubes. Using a rat-tail file, round off all sharp edges and burrs. Grease the telescopic profile generously before reassembling.

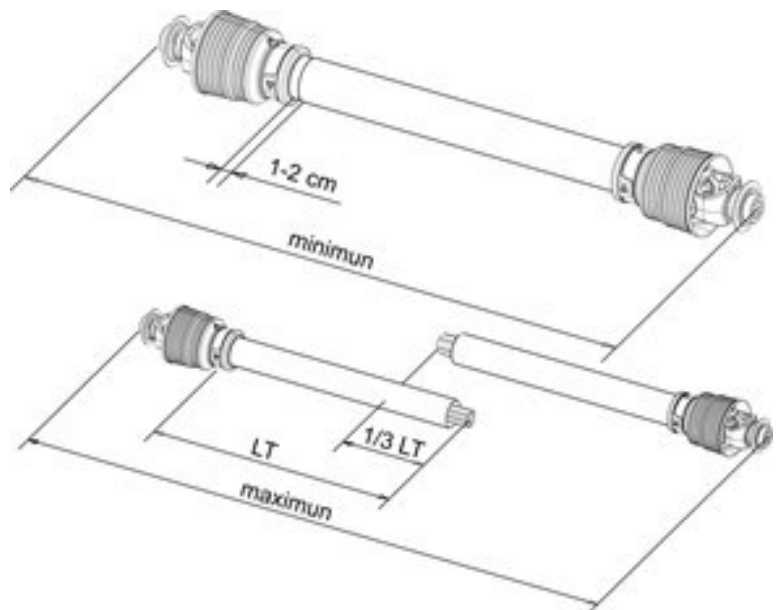

When fully extended, the tubes must overlap by at least 1/3 of the length of the pipes (LT). When retracted, the min. acceptable clearance is 1-2 cm (3/8”-3/4”)

Scan the QR code below for more detailed information on PTO installation.



Adjusting Belt Rake

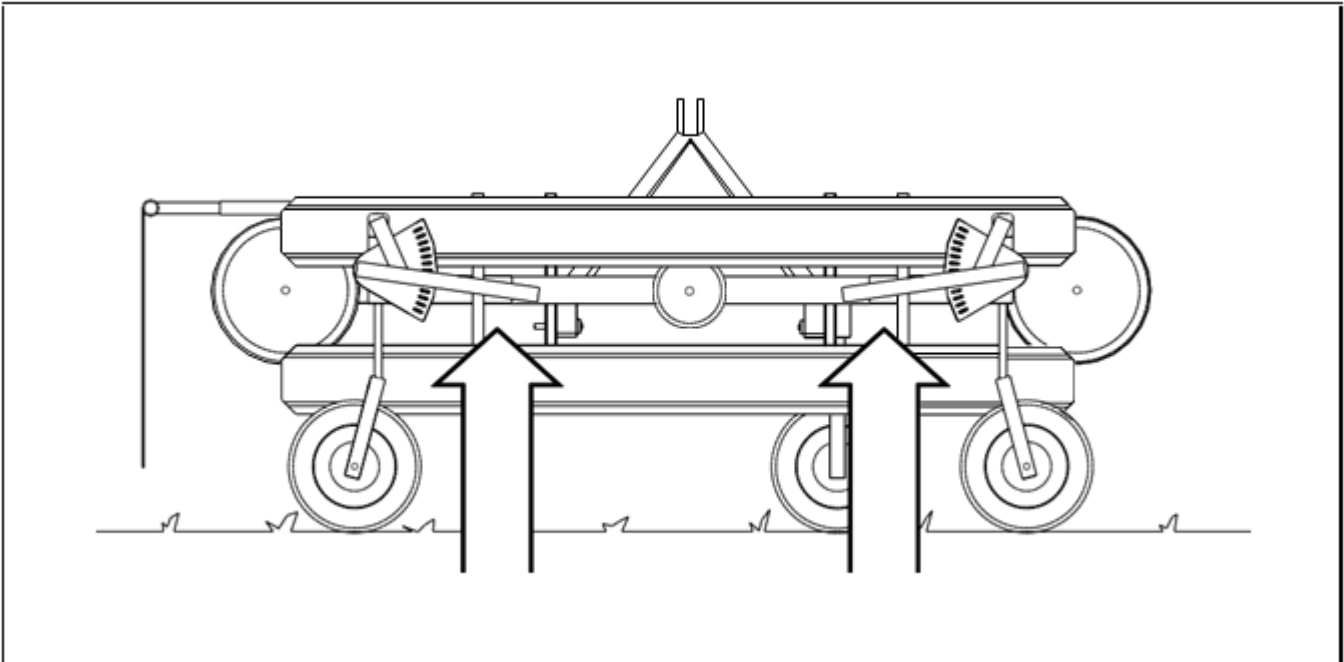

- With the two bars above the wheels, adjust the windrower's work surface in such a way that the teeth almost touch the ground.
- Pull out the hay stopper until it reaches the required width and then lock it in place with the catch.
- Proceed at a speed of around 18 km/h - 11 mph.
- The belt-type windrower can also work in reverse.

Periodic Maintenance:

- Carry out all operations with the tractor shut down and the agricultural machine set on the ground.
- Check every time the windrower is used that the belts have not slipped and the teeth supports are correctly perpendicular to the belts.
- Change the bushings fixed on the chain if they are worn out.
- Grease the struts of the wheels.

Lifting Belt Rake

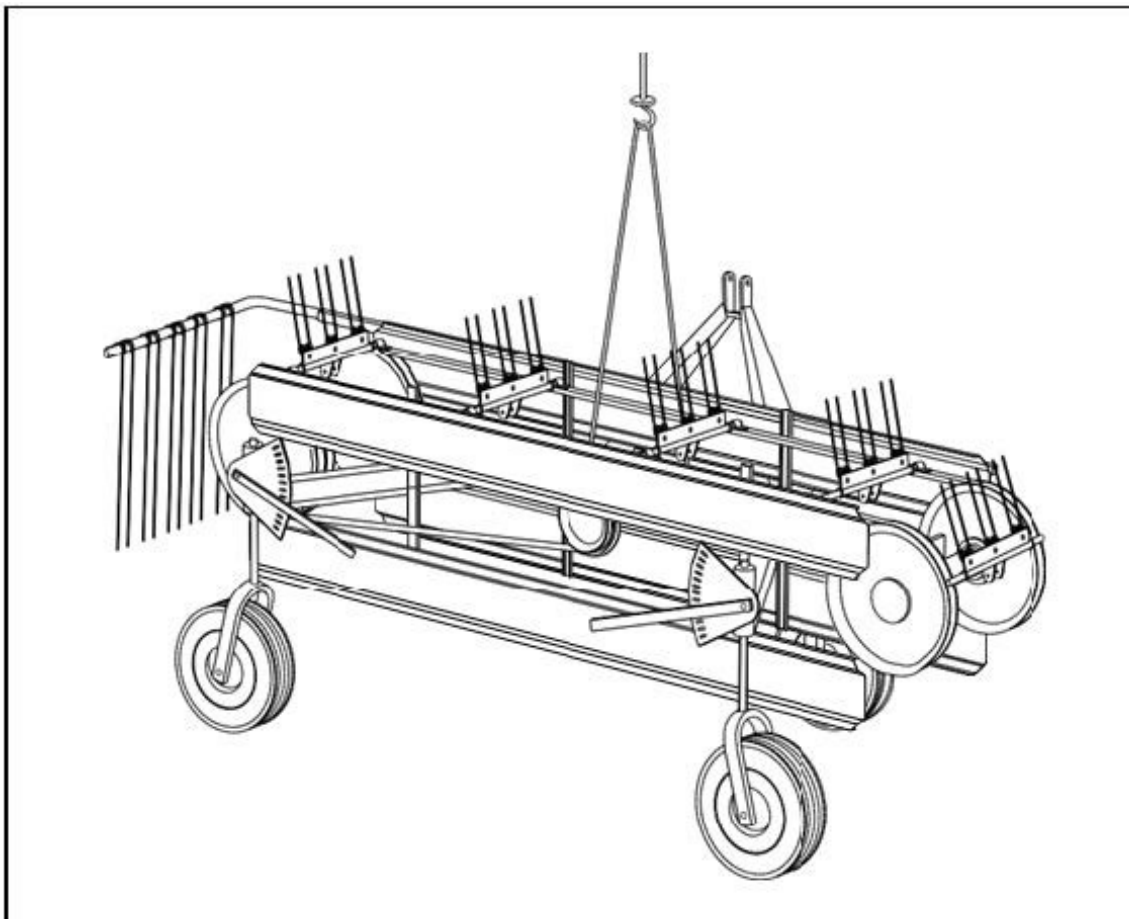

To load the belt-type windrower with a hoist, insert a belt straddling the power take off and the frame, fix the two ends of the belt to the crane hook.

Torque Specs

Torque Specifications for Common Bolt Sizes															
Inches		Bolt Head Identification						Metric		Bolt Head Identification					
		Grade 2		Grade 5		Grade 8		Class 5.8		Class 8.8		Class 10.9			
Bolt size (inches)	Thread pitch	N.m	ft-lb	N.m	ft-lb	N.m	ft-lb	Bolt size (metric)	Thread pitch	N.m	ft-lb	N.m	ft-lb	N.m	ft-lb
1/4"	20	7	5	11	8	16	12	M5	0.08	4	3	6	4	9	7
1/4"	28	8	6	13	10	19	14	M6	1	6	4	10	7	15	11
5/16"	18	15	11	24	17	33	25	M8	1.25	16	12	25	18	36	27
5/16"	24	17	13	26	19	37	27	M8	1	17	13	26	19	38	28
3/8"	16	27	20	42	31	59	44	M10	1.5	31	23	48	35	71	52
3/8"	24	31	23	47	35	67	49	M10	1.25	33	24	51	38	75	55
7/16"	14	43	32	67	49	95	70	M10	1	35	26	53	39	78	58
7/16"	20	48	36	75	55	106	78	M12	1.75	54	40	84	62	123	91
1/2"	13	66	48	102	75	144	106	M12	1.5	56	41	87	64	128	94
1/2"	20	75	55	115	85	163	120	M12	1.25	59	44	90	66	133	98
9/16"	12	95	70	147	109	208	154	M14	2	84	62	133	98	195	144
9/16"	18	106	79	164	121	232	171	M14	1.5	94	69	142	105	209	154
5/8"	11	132	97	203	150	287	212	M16	2	131	97	206	152	302	223
5/8"	18	149	110	230	170	325	240	M16	1.5	141	104	218	161	320	236
3/4"	10	233	172	361	266	509	376	M18	2.5	181	133	295	218	421	310
3/4"	16	261	192	403	297	569	420	M18	2	196	145	311	229	443	327
7/8"	9	226	167	582	430	822	606	M18	1.5	203	150	327	241	465	343
7/8"	14	249	184	642	473	906	668	M20	2.5	256	189	415	306	592	437
1"	8	339	250	873	644	1232	909	M20	1.5	288	212	454	335	646	476
1"	12	371	273	955	704	1348	995	M22	2.5	344	254	567	418	807	595
1-1/8"	7	480	354	1077	794	1746	1288	M22	1.5	381	281	613	452	873	644
1-1/8"	12	539	397	1208	891	1958	1445	M24	3	444	327	714	526	1017	750
1-1/4"	7	677	500	1519	1120	2463	1817	M24	2	488	360	769	567	1095	808
1-1/4"	12	750	553	1682	1241	2728	2012	M27	3	656	484	1050	774	1496	1103
1-3/8"	6	888	655	1992	1469	3230	2382	M27	2	719	530	1119	825	1594	1176
1-3/8"	12	1011	746	2268	1673	3677	2712	M30	3.5	906	668	1420	1047	2033	1499
1-1/2"	6	1179	869	2643	1949	4286	3161	M30	2	1000	738	1600	1180	2250	1659
1-1/2"	12	1326	978	2974	2194	4823	3557	M36	4	1534	1131	2482	1830	3535	2607

Notes:

This chart is an approximate estimate of torque values.

Always tighten hardware to these values unless a different torque value or tightening procedure is listed for a specific application.

Fasteners must always be replaced with the same grade as specified in the manual.

Always use the proper tool for tightening hardware: SAE for SAE hardware and Metric for Metric hardware.

Make sure that fastener threads are clean and that you properly start thread engagement.

Page left blank intentionally



Belt Rake D150, D180

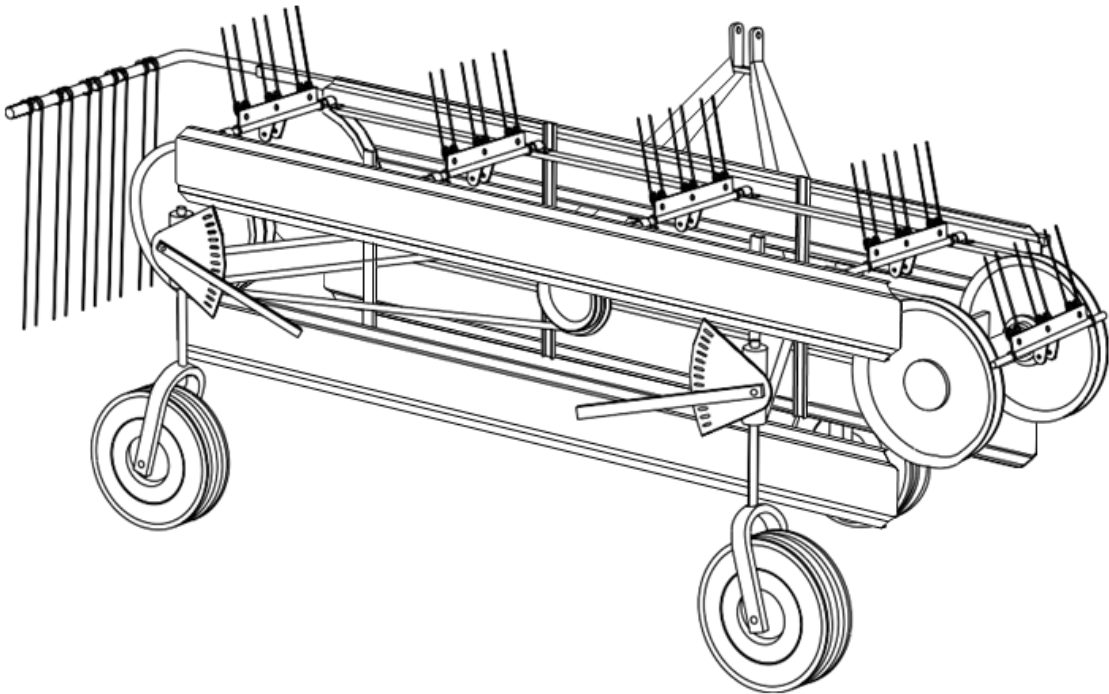

Parts Manual

Belts

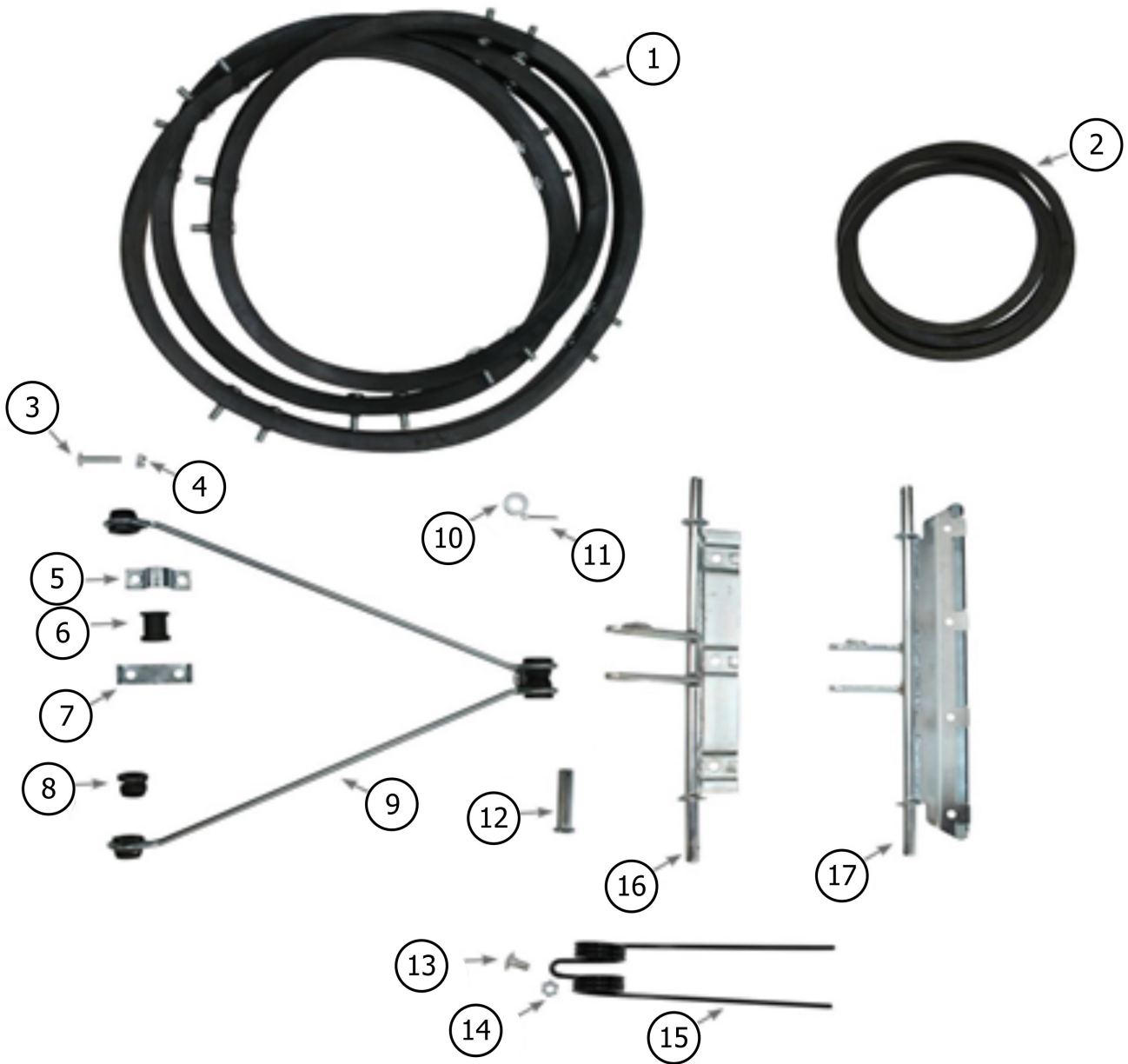

Belts

Item	Part #	Description	Qty.
1	9500011	Belt with screw D150	2
	9500012	Belt with screw D180	2
2	9500016	Belt C83-D150	1
	9500017	Belt C99-D180	1
3	9130807	Screw TT TBL M8 x 35	40
4	LN08125	Lock nut M8-1.25	40
5	7500220	Bridge	20
6	9500110	Nylon support	10
7	7500210	Plate	20
8	9500100	Nylon bush	20
9	6900060	Double tension rod	10
	6900065	Tension rod with bushing	10
10	9150016	Flat washer 24x14x1.5	20
11	9106032	Pin D.3,2x25	20
12	9140001	Pin D.14	10
13	9131004	Carriage bolt M10x20	30-48
14	NM1015	Nut M10-1.5	30-48
15	DR6900020	Spring DM 6 black	30-48
16	DR7500230	3 Teeth support	10
17	7500235	4 Teeth support	12

Wheels



Wheels

Item	Part #	Description	Qty.
1	7500075	Special plug	2
2	9106010	Hexagon set screw	2
3	9105003	Grease GN085	2
4	LN12175	Nut M12-1.75	1
5	7500018	Support DM.30 L four wheel 15/600/6	1
6	8910006	Wheel 15/600/6 complete	2
7	7500015	Support DM.30 R Four wheel 15/600/6	1
8	LN1620	Nut M16-2.0	3
9	8910107	External wheel protection	2
10	8910106	Internal wheel protection	2
11	6900112	Pin DM 10x56	1
12	7500141	Wheel support 40x40x3x825	1
13	8910208	Wheel 300x60 PVC F25 MM	1
14	LN1620	Nut 16-2.0	2
15	9150042	Fender washer 17x30x3	1

Pulleys

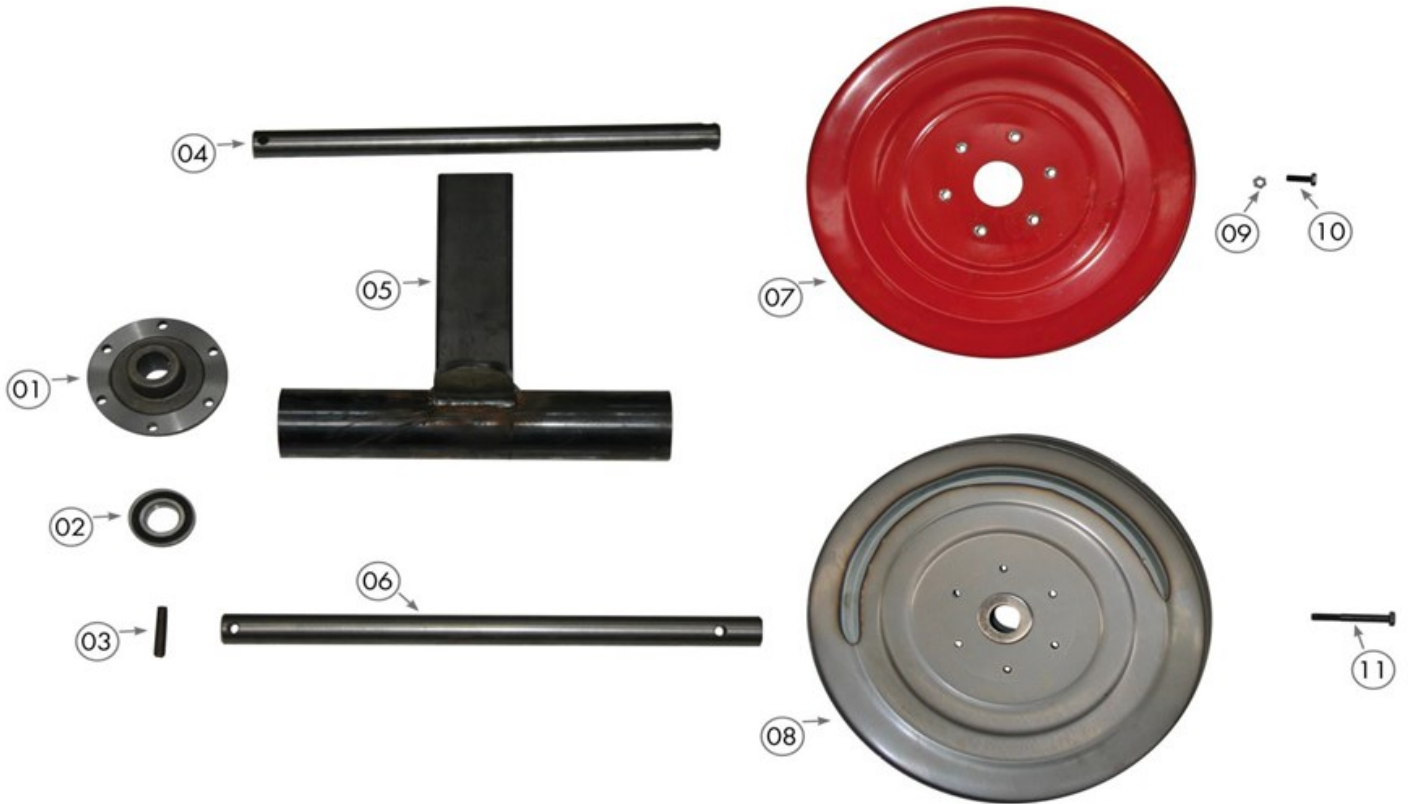

Pulleys

Item	Part #	Description	Qty.
1	7500190	Flange	4
2	B6206ZZ	Bearing 6206ZZ	-
3	9141010	Roll pin 10x50	3
4	7500185	Double pully shaft	1
5	7500170	Pulley support	2
6	7500180	Pulley shaft	1
7	7500110	Pulley MM400	1
8	7500120	Pulley 2G MM400	3
9	NM08125	Nut M8-1.25	24
10	BM0812525	Bolt M8-1.25x25	18
11	BM0812570	Bolt M8-1.25x70	6

Drive Shaft

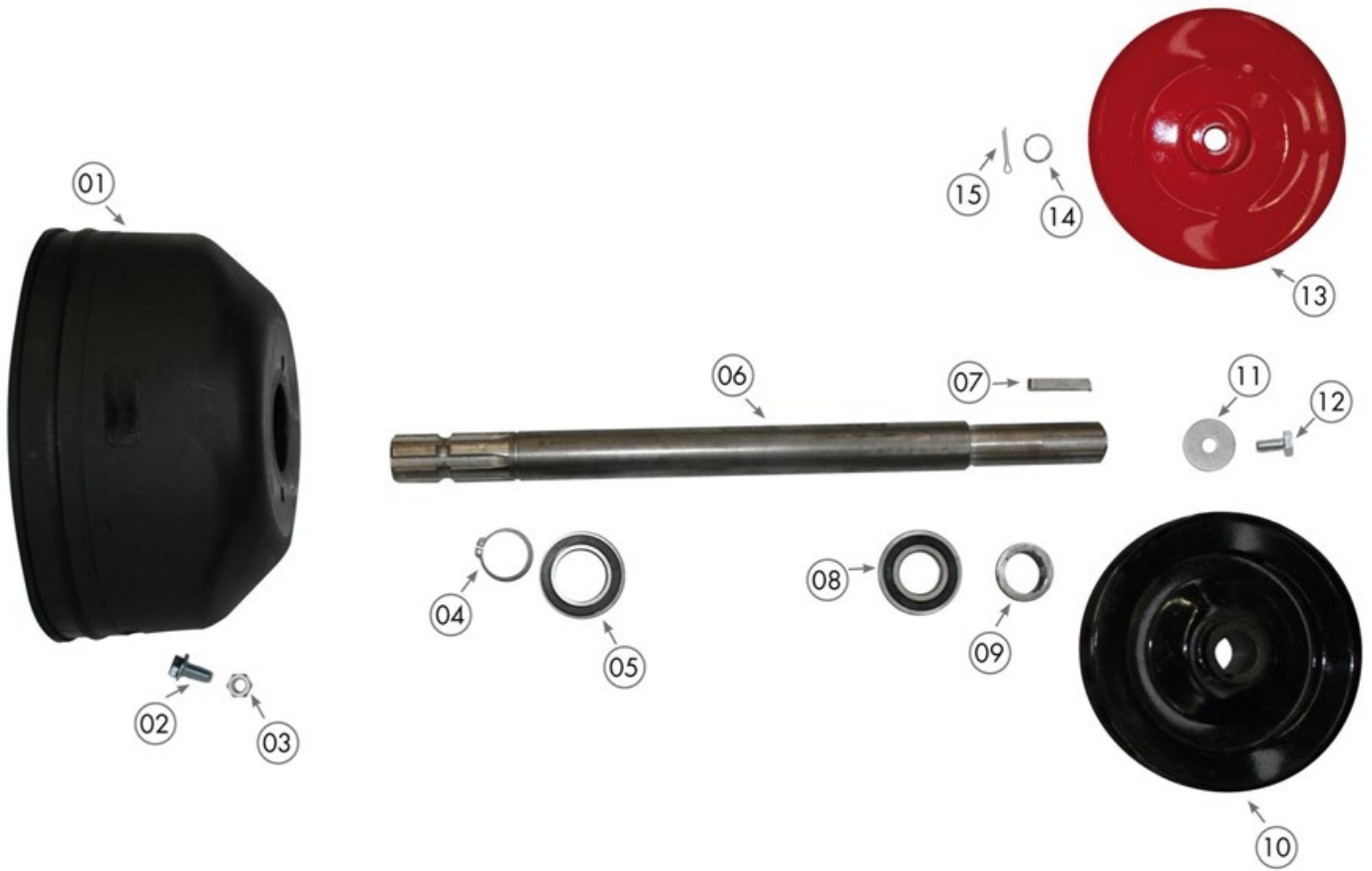

Drive Shaft

Item	Part #	Description	Qty.
1	9500207	Protection shaft	1
2	FBM1012520	Flange bolt M10-1.25x20	2
3	LN10125	Nut M10-1.25	2
4	SRE30	Snap ring external M30	1
5	B60072RS	Bearing	1
6	7500131	Shaft	1
7	KM080835	Key 8x8x35	1
8	B62062RS	Bearing	1
9	7500081	Spacer	1
10	7500101	Pulley	1
11	9150012	Flat washer M10	1
12	BM1012520	Screw	1
13	7500090	Pulley (D180 only)	2
14	7500080	Spacer (D180 only)	2
15	9106031	Pin D.3x2.5 (D180 only)	2

Protection

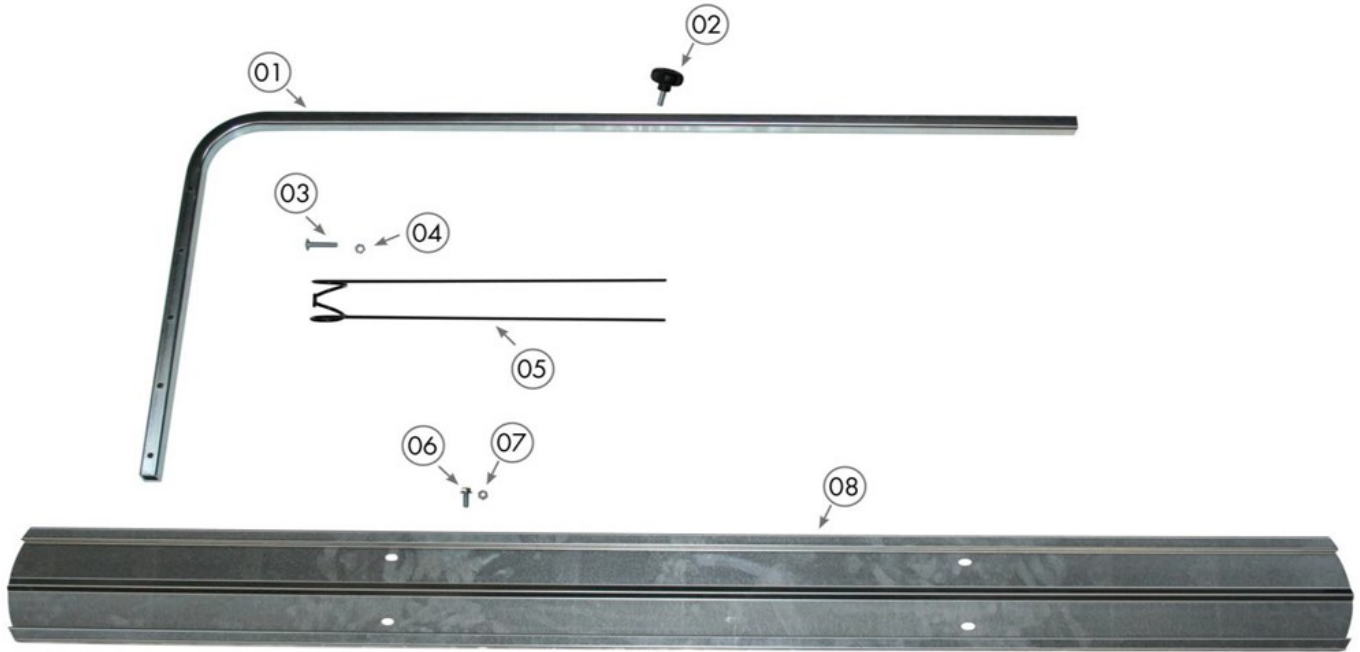

Protection

Item	Part #	Description	Qty.
1	7500200	Hay stopper arm	1
2	9140002	Handle screw M10	1
3	9110808	Screw TBL M8x40	5
4	NM08125	Nut M8-1.25	5
5	6900030	Hay stopper spring	5
6	FBM0812520	Bolt M8x20 with washer	16
7	NM08125	Nut M8-1.25	16
8	7500020	Protection D150	4
	7500030	Protection D180	4

Frame

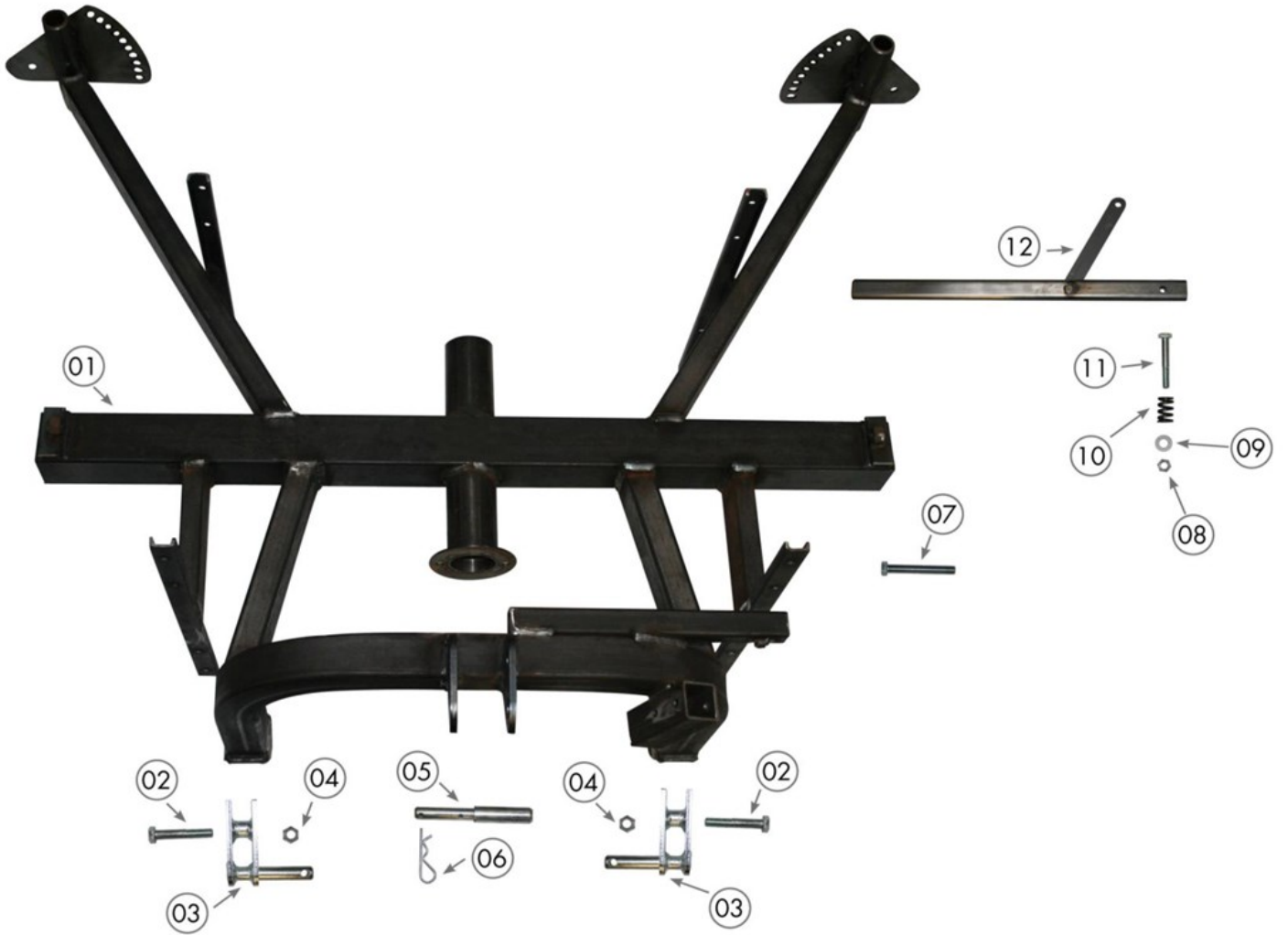

Frame

Item	Part #	Description	Qty.
1	7500251	Frame D150	1
	7500260	Frame D180	1
2	BM162090	Bolt M16-2.0x90	2
3	7500160	Hitch bracket	2
4	LN1620	Lock nut M16-2.0	2
5	6500375	Top pin	1
6	RC4	R clip	1
7	BM1620120	Bolt M16-2.0x120	2
8	LN12175	Nut M12-1.75	2
9	FW12	Flat washer M12	2
10	6900070	Spring	2
11	BM1217580	Bolt M12-1.75x80	2
12	7500050	Arms	2

Warranty

LIMITED WARRANTY

Belco Resources Equipment warrants to the original purchaser of any new piece of machinery from Belco Resources Equipment, purchased from an authorized Belco Resources Equipment dealer, that the equipment be free from defects in material and workmanship for a period of one (1) year for non-commercial, state, and municipalities' use, ninety (90) days for commercial use from date of retail sale. Warranty for rental purposes is thirty (30) days. The obligation of Belco Resources Equipment to the purchaser under this warranty is limited to the repair or replacement of defective parts.

Replacement or repair parts installed in the equipment covered by this limited warranty are warranted for ninety (90) days from the date of purchase of such part or to the expiration of the applicable new equipment warranty period, whichever occurs later. Warranted parts shall be provided at no cost to the user at an authorized Belco Resources Equipment dealer during regular working hours. Belco Resources Equipment reserves the right to inspect any equipment or parts, which are claimed to have been defective in material or workmanship.

This limited warranty does not apply to and excludes wear items such as shear pins, tires, tubes knives, blades or other wear items. Oil or grease is not covered by this warranty.

All obligations of Belco Resources Equipment under this limited warranty shall be terminated if:

Proper service is not performed on the machine.

The machine is modified or altered in any way.

The machine is being used or has been used for purposes other than those for which the machine was intended.

DISCLAIMER OF IMPLIED WARRANTIES & CONSEQUENTIAL DAMAGES

Belco Resources Equipment obligation under this limited warranty, to the extent allowed by law, is in lieu of all warranties, implied or expressed, including implied warranties of merchantability and fitness for a particular purpose and any liability for incidental and consequential damages with respect to the sale or use of the items warranted. Such incidental and consequential damages shall include but not be limited to: transportation charges other than normal freight charges; cost of installation other than cost approved by Belco Resources Equipment; duty; taxes; charges for normal service or adjustment; loss of crops or any other loss of income; rental of substitute equipment, expenses due to loss, damage, detention or delay in the delivery.

REGISTRATION

The online Warranty Registration must be completed in order to qualify for coverage on this Limited Warranty. Visit br-equipment.com, click on "Warranty Registration" and completely fill out the form to register the new piece of equipment.

Page left blank intentionally



401 Jeffreys Road
Rocky Mount, NC 27804
www.tarrivermfg.com

Tel: 252-822-7140
Fax: 252-787-5855
Sales@tarrivermfg.com