

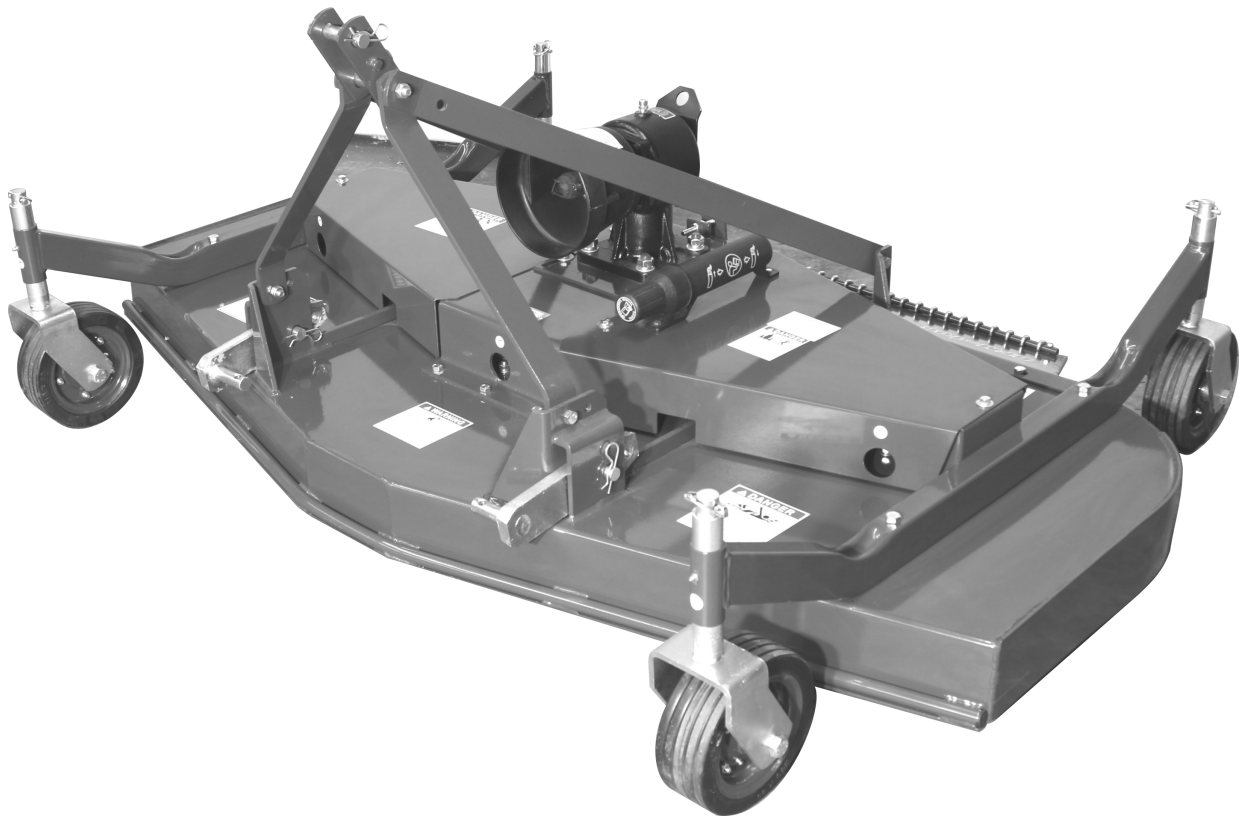

Rear Discharge Finishing Mower

BFM-100 Series



Operator's Manual

Rev. 02/26

Page left blank intentionally

TO THE DEALER:

Assembly and proper installation of this product is the responsibility of the Tar River dealer. Read manual instructions and safety rules. Make sure all items on the Dealer's Pre-Delivery and Delivery Check Lists in the Owner's/Operator's Manual are completed before releasing equipment to the owner.

TO THE OWNER:

Read this manual before operating your Tar River equipment. The information presented will prepare you to do a better and safer job. Keep this manual handy for ready reference. Require all operators to read this manual carefully and become acquainted with all the adjustment and operating procedures before attempting to operate. Replacement manuals can be obtained from your selling dealer. The equipment you have purchased has been carefully engineered and manufactured to provide dependable and satisfactory use. Like all mechanical products, it will require cleaning and upkeep. Lubricate the unit as specified. Observe all safety information in this manual and safety decals on the equipment. For service, your authorized Tar River dealer has trained mechanics, genuine Tar River service parts, and the necessary tools and equipment to handle all your needs. Use only genuine Tar River service parts. Substitute parts will void the warranty and may not meet standards required for safe and satisfactory operation.

Record your implement model and serial number in the space provide below. Your dealer will need this information to give you prompt, efficient service.

Model Number: _____

Serial Number: _____

Date Purchased: _____

Table of Contents

Introduction..... 5

Technical Specifications..... 5

Safety..... 6

Safety Signal Words..... 6

General Safety Guidelines..... 7

Safety Decal Care..... 7

Before Operation..... 8

During Operation..... 9

Highway And Transport Operations..... 10-11

Assembly..... 12-14

Attaching Machine to Tractor..... 15

PTO Driveline Instructions..... 16-19

Operating Instructions..... 20

Maintenance..... 21-22

Trouble Shooting..... 23

Torque Specifications..... 24

Parts Breakdown..... 25-37

Warranty..... 38

Introduction

Thank you for purchasing your BFM-100 Series Finishing Mower. Keep your grassy areas looking good with the 100 Series Economy Finishing Mower by Tar River Implements. These mowers are great for compact tractors maintaining home estates and light landscaping. Available in working widths of 58", 71" and 82".

All Mowers come standard with safety chains. The BFM-107 model comes standard with front anti-scalp roller.

Technical Specifications

- Solid rubber tires
- Rear discharge
- Floating hitch
- Easy cutting height adjustment
- Easy belt tension adjustment
- Powder coat paint
- Category 1 hitch

Model:	BFM-105	BFM-106	BFM-107
Weight	435 lbs.	544 lbs.	639 lbs.
Req. HP	15-30	15-30	25-50
Working width	58"	71"	82"
Overall width	59"	72"	86"
Number of blades	3	3	3
Grass discharge	Rear discharge	Rear discharge	Rear discharge
Tires	Solid rubber	Solid rubber	Solid rubber

Important Safety Information

Safety

It is important that you read the entire manual and to become familiar with this product before you begin using it. This product is designed for certain applications only. The manufacturer cannot be responsible for issues arising from modification. We strongly recommend this product not be modified and /or used for any application other than that for which it is designed. If you have any questions relative to a particular application, DO NOT use the product until you have first contacted us to determine if it can or should be performed on the product.

Read and understand this manual and all safety signs before operating and maintaining . Review the safety instructions and precautions annually.

Safety Signal Words

TAKE NOTE! This safety alert symbol found though out this manual is used to call you attention to instructions involving you personal safety and the safety of others. Failure to follow these instructions can result in injury or death.



**This symbol means:
Attention!
Become alert!
Your safety is involved!**

Note the use of the signal words, **DANGER, WARNING and CAUTION** with the safety messages. The appropriate signal word for each has been selected using the following guidelines:



DANGER: Indicates an imminently hazardous situation that, if not avoided, will result in death or serious injury. This signal word is to be limited to the most extreme situations typically for machine components which, for functional purposes, cannot be guarded.



WARNING: Indicates a potentially hazardous situation that, if not avoided, could result in death or serious injury, and includes hazards that are exposed when guards are removed. It may also be used to alert against unsafe practices.



CAUTION: Indicates a potentially hazardous situation that, if not avoided, may result in minor or moderate injury. It may also be used to alert against unsafe practices.

Important Safety Information

General Safety Guidelines

Safety of the operator is one of the main concerns in designing and developing a new piece of equipment. Designers and manufacturers build in as many safety features as possible. However, every year many accidents occur which could have been avoided by a few seconds of thought and a more careful approach to handling equipment. You, the operator, can avoid many accidents by observing the following precautions in this section. To avoid personal injury, study the following precautions and insist those working with you, or for you, follow them.

Replace any **DANGER, WARNING, CAUTION** or instruction safety decal that is not readable or is missing. Location of such decals are indicated in this manual. Do not attempt to operate this equipment under the influence of drugs or alcohol.

Review the safety instructions with all users annually.

This equipment is dangerous to children and persons unfamiliar with its operation. The operator should be a responsible adult familiar with farm machinery and trained in this equipment's operations. **Do not allow persons to operate or assemble this unit until they have read this manual and have developed a thorough understanding of the safety precautions and of how it works.**

To prevent injury of death, use a tractor equipped with a Roll Over Protection System (ROPS). Do not paint over, remove or deface any signs or warning decals on your equipment. Observe all safety signs and practice the instructions on them.

Never exceed the limits of a piece of machinery. If its ability to do a job, or to do so safely, is in question, **Don't try it!**



Safety Decal Care

- Keep safety signs clean and legible at all times.
- Replace safety signs that are missing or have become illegible.
- Replaced parts that displayed a safety sign should also display the current safety sign
- Safety signs are available from your Distributor or Dealer Parts Department or the factory.

Important Safety Information

How to install Safety Signs:

- Be sure that the installation area is clean and dry.
- Decide on the exact position before you remove the backing paper.
- Remove the smallest portion of the split backing paper.
- Align the decal over the specified area and carefully press the small portion with the exposed sticky backing in place.
- Slowly peel back the remaining paper and carefully smooth the remaining portion of the decal in place.
- Small air pockets can be pierced with a pin and smoothed out using the piece of decal backing paper.



Before Operation

- Carefully study and understand this manual.
- Do not wear loose-fitting clothing, which may catch in moving parts.
- Always wear protective clothing and substantial shoes.
- Assure that all tires are inflated evenly.
- Give the unit a visual inspection for any loose bolts, worn parts or cracked welds, and make necessary repairs. Follow the maintenance safety instructions included with this manual.
- Be sure that there are no tools lying on or in the equipment.
- Do not use the unit until you are sure that the area is clear, especially of children and animals.
- Don't hurry the learning process or take the unit for granted. Ease into it and become familiar with your new equipment.
- Practice operation of your equipment and its attachments. Completely familiarize yourself and other operators with its operation before using.
- Use a tractor equipped with a Roll Over Protection System (ROPS) and fasten your seat belt prior to starting engine.
- The manufacturer does not recommend usage of tractor with ROPS removed.
- Move tractor wheels to the widest recommended settings to increase stability.
- Securely attach to towing unit. Use a high strength, appropriately sized hitch pin with a mechanical retainer and attach safety chain.
- Do not allow anyone to stand between the tongue or hitch and the towing vehicle when backing up to the equipment.
- Do not use the unit until you are sure that the area is clear, especially of children and animals.

Important Safety Information



During Operation

- Children should not be allowed on the machine.
- Clear the area of small children and bystanders before moving the machine.
- If using a towing unit, securely attach machine by using a hardened 3/4" pin, a metal retainer, and safety chains if required. Shift towing unit to a lower gear before going down steep downgrades, thus using the engine as a retarding force. Keep towing vehicle in gear at all times. Slow down for corners and rough terrain.
- Make sure you are in compliance with all local and state regulations regarding transporting equipment on public roads and highways. Lights and slow moving signs must be clean and visible by overtaking or oncoming traffic when machine is transported.
- Beware of bystanders, **particularly children!** Always look around to make sure that it is safe to start the engine of the towing vehicle or move the unit. This is particularly important with higher noise levels and quiet cabs, as you may not hear people shouting.
- **NO PASSENGERS ALLOWED!** Do not carry passengers anywhere on, or in, the tractor or equipment, except as required for operation.
- Keep hands and clothing clear of moving parts.
- Do not clean, lubricate or adjust your equipment while it is moving.
- When halting operation, even periodically, set the tractor or towing vehicle brakes, disengage the PTO, shut off the engine and **remove the ignition key.**
- Be especially observant of the operating area and terrain. Watch for holes, rocks or hidden hazards. Always inspect the area prior to operation.
- **DO NOT** operate near the edge of drop-offs or banks.
- **DO NOT** operate on steep slopes as overturns may result.
- Operate up and down (not across) intermediate slopes. Avoid sudden starts and stops.

Important Safety Information



Highway and Transport Operations

- Adopt safe driving practices.
- Keep the brake pedals latched together at all times. **Never use independent braking with machine in tow as loss of control and/or upset of unit can result.**
- Always drive at a safe speed relative to local conditions and ensure that your speed is low enough for an emergency stop to be safe and secure. Keep speed at a minimum.
- Reduce speed prior to turns to avoid the risk of overturning.
- Avoid sudden uphill turns on steep slopes.
- Always keep the tractor or towing vehicle in gear to provide engine braking when going downhill. Do not coast.
- Do not drink and drive!
- Comply with state and local laws governing highway safety and movement of farm machinery on public roads.
- Use approved accessory lighting, flags and necessary warning devices to protect operators of other vehicles on the highway during daylight and nighttime transport. Various safety lights and devices are available from your dealer.
- The use of flashing amber lights is acceptable in most localities. However, some localities prohibit their use. Local laws should be checked for all highway and marking requirements.
- When driving the tractor and equipment on the road or highway under 40 kph (20 mph) at night or during the day, use the amber warning lights and a slow moving vehicle (SMV) identification emblem.
- Plan your route to avoid heavy traffic.
- Be a safe and courteous driver. Always yield to oncoming traffic in all situations, including narrow bridges, intersections, etc.
- Be observant of bridge loading ratings. Do not cross bridges rated at lower than the gross weight at which you are operating.
- Watch for obstructions overhead and to the side while transporting.
- Always operate in a position to provide maximum visibility at all times. Make allowances for increased length and weight of the equipment when making turns, stopping the unit, etc.
- Pick the most level route when transporting across fields. Avoid the edges of ditches or gullies and steep hillsides.
- Be extra careful when working in inclines.

Important Safety Information



Highway and Transport Operations

- Maneuver the tractor or towing vehicle at safe speeds.
 - Avoid overhead wires or other obstacles. Contact with overhead lines could cause serious injury or death.
 - Avoid loose fill, rocks and holes, they can be dangerous for equipment operation or movement.
 - Allow for unit length when making turns,
 - Operate the towing vehicle from the operator's seat only.
 - Never stand alongside of unit with engine running or attempt to start engine and/or operate machine while standing alongside of unit.
 - Never leave running equipment attachments unattended.
 - As a precaution, always recheck the hardware on equipment following every 100 hours of operation.
- Correct all problems. Follow the maintenance safety procedures.

Assembly

Step 1: Attach the rear brace bars to the lugs on the rear of deck with M12-1.75x40 hex bolt and M12-1.75 locking nut. Attach the A-frame bars to the lugs on the front of the mower deck with M12-1.75x40 bolts and M12-1.75 locking nuts.

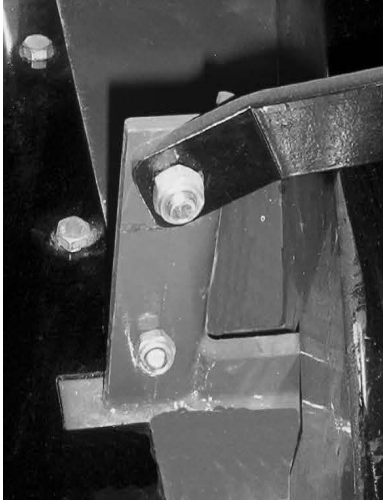

Rear Brace



Front Brace

Step 2: Connect all braces at the top of the A-frame with a M12 bolt, spacer, hitch connection and locking nut.

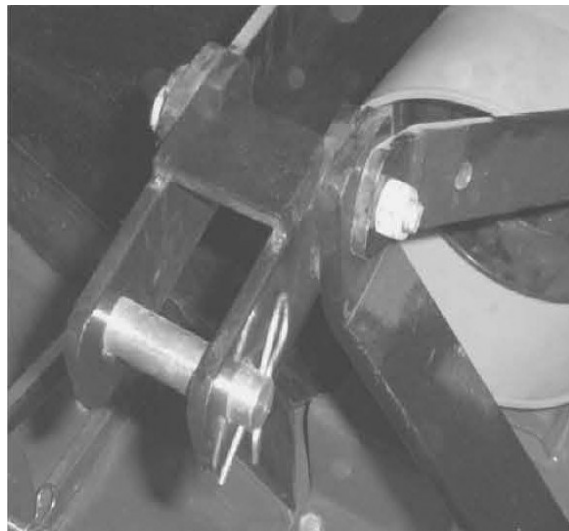

Assembly

Step 3: Install the wheel support braces with M12 bolts (BFM105&106), M16 bolts (BFM107) and locking nuts as shown below.

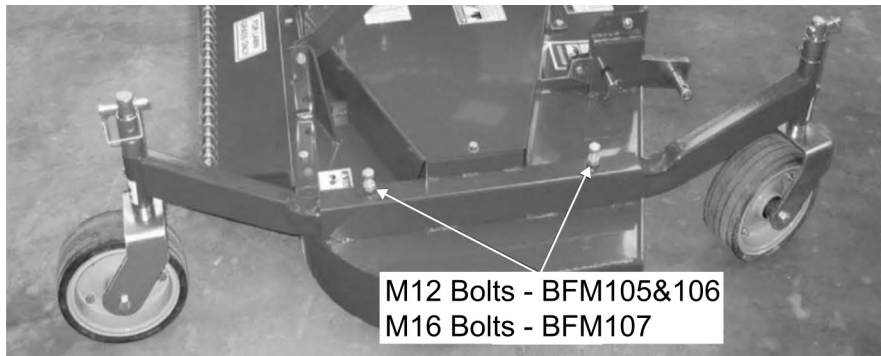

Step 4: Install rear discharge chute and safety chains using M10 bolts, lock washers, flat washer and hex nuts as shown below.

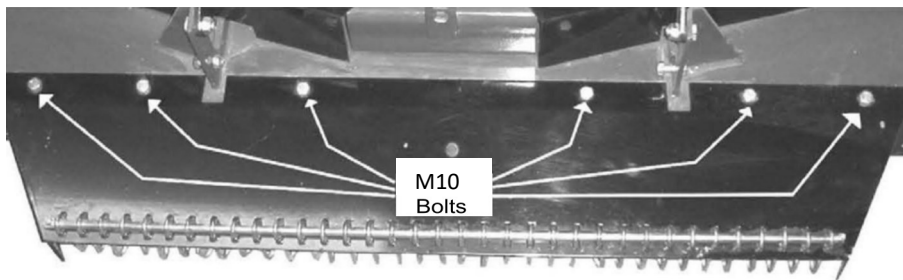

Step 5: Cutting height adjustment.

Support the unit securely when changing wheel height spacers.

Remove the pin from the wheel yoke and remove wheel yoke from wheel arm. Increase mower cutting height by placing spacers below the wheel arm. Decrease cutting height by placing spacers above the wheel arm. Re-attach wheel yoke and secure with pin. Each wheel yoke must have the same combination of spacers in order to cut even.

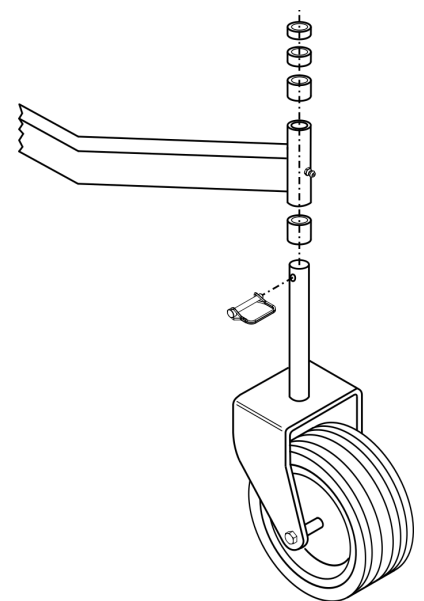

Assembly

Step 6: Place the covers (13) on the belts, tighten the handles on the frame (14) and on the gearbox support (15). Attach the PTO shield (16) by means of four screws (17) and the washers (18).

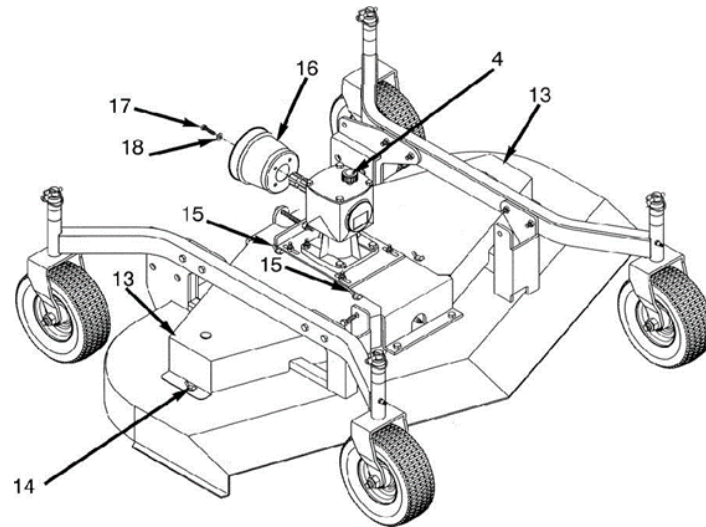

Step 7: Install the uprights (19) on the machine and insert the bolts (21), and relative nuts (22). Install the tie rods (20) on the machine and insert the bolts (23), with relative nuts (24). Place the top link (25) on both tie-rods and uprights, by inserting the spacer (26) between the top link and the tie-rods; finally tighten the screw (27) with the nut (28) and the washer (29). Make sure that the top link turns freely on the bolt. Finally tighten the bolts (21) with the nuts (22) and the bolts (23) with the nuts (24). Install the lower hitches (30) on the supports (31); adjust the length and install the pins (32) anchoring them by means of the split pins (33).

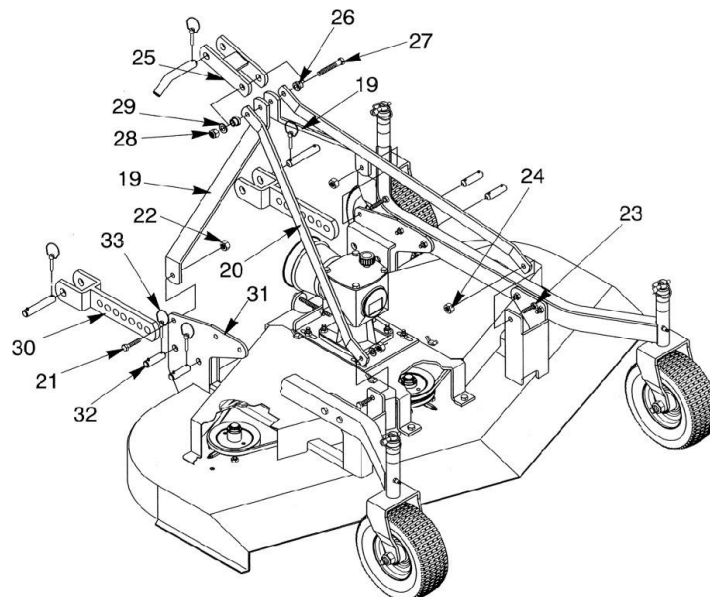

Attaching Machine to Tractor



Warning: When attaching the BFM Series Finish Mower, *Never* allow anyone to stand between the BFM Series Finish Mower and the tractor. Serious injury or death can occur!

Attaching the BFM Series Finish Mower

Carefully read this instruction manual and the manuals of the tractor and PTO shaft manufacturer. All mowers are built to be attached to any tractor equipped with a three-point lift of the correct category and with suitable ball ends.

Before attaching the equipment to the tractor, make sure that the ground is smooth and flat and that nobody is standing between the tractor and the mower; slowly move the tractor towards the mower by aligning the tractor lifter arms with the two mower coupling side pins; turn the engine off and pull the brake.

It is possible to adjust the attachment position by releasing the pins, A and modifying the position of the plates B.

Connect the tractor top link to the third upper point by removing the pin located between the two plates, inserting the top link and securing it by means of the pin.

Adjust the top link so that the upper part of the frame is parallel to the ground. Block all the linking parts by means of the sway chains or arms.

Make sure that the central unit axis (case/bevel gear pair) is parallel to the ground, thus minimizing the stresses on the power take off and increasing the working life of the equipment.

Before installing the PTO shaft make sure that the RPM rating and the direction of rotation match those of the tractor. Carefully read the PTO shaft and tractor instructions.

Furthermore, accurately read the instructions of the manufacturer of the PTO shaft and of the tractor. Before starting any activity, make sure that the guards are installed on the power take off of the tractor and PTO shaft. Make sure that they cover the PTO shaft throughout its length.

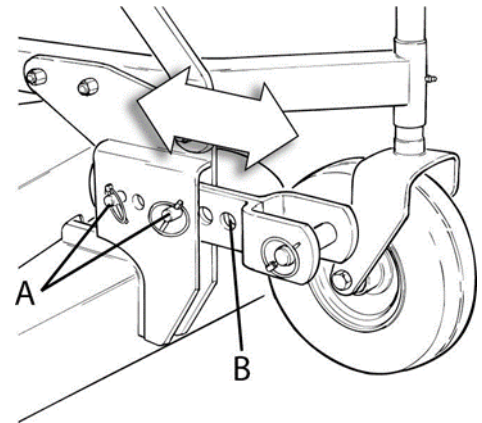

PTO Driveline Instructions

Instructions for Installing a PTO Driveline:

(Refer to Fig. 1)

1. Begin by parking the tractor and implement on a level, solid surface. Attach the implement to the tractor's hitch arms, upper and lower. Adjust the tractor's 3-point hitch so that the tractor's output shaft is level with the implement's input shaft.
2. Leave the tractor in gear, shut off the tractor engine, remove the key and set the park brake. Block the implement to prevent it from falling over or shifting.
3. Slide the inner yoke of the PTO shaft 'A' (implement end) onto the input shaft of the implement. Make sure the yoke is securely locked in place.
4. Slide the outer yoke of the PTO shaft 'B' (tractor end) onto the tractor input shaft. Make sure the yoke is securely locked in place.
5. Because of differences in tractor 3-point arms and implements, it may be necessary to shorten the PTO Driveline. See page 4 for "**Instructions for Shortening a PTO Driveline**".
6. Check that the PTO Driveline yokes are securely attached to the tractor and implement before operating. PTO Drivelines not attached properly can cause serious injury or death!
7. If your PTO Driveline shields are equipped with chains, secure the chain to the tractor and or implement to prevent the shield from rotating.
8. Before starting tractor and engaging the PTO Driveline, make certain there are no people or animals between tractor and implement. Rotating PTO Drivelines can cause serious injury or death!

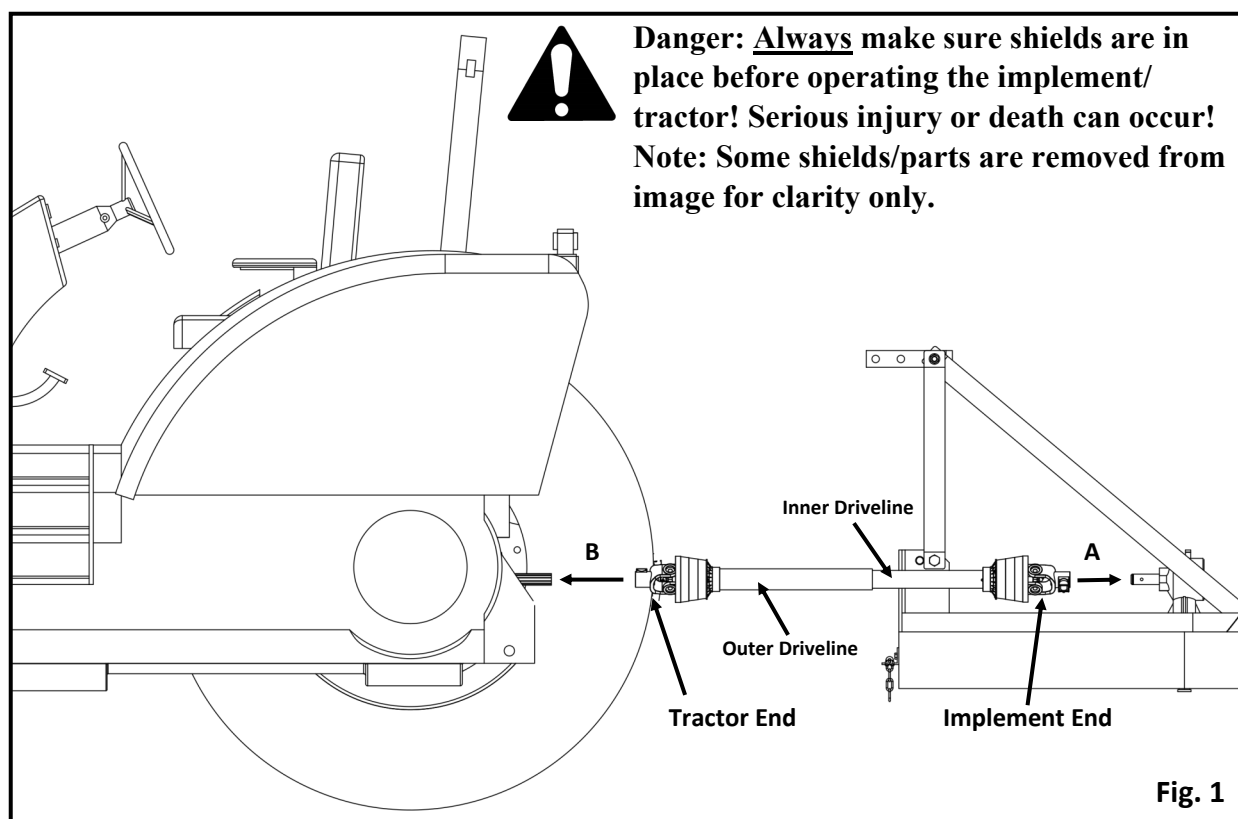

PTO Driveline Instructions

Instructions for Shortening a PTO Driveline:

(Refer to Fig. 2)



Note: If you are not confident modifying the PTO Driveline, you should contact a Qualified Professional.

1. Separate the inner and outer PTO Drivelines. Leave separated at this time.
2. Attach the outer PTO Driveline to the tractor implement input shaft and inner PTO driveline to the implement input shaft.
3. With the drivelines parallel to one another, measure 1" (dim. 'B') back from the outer PTO Driveline shield (see fig. 2) and make a mark on the inner PTO Driveline.
4. Measure 1" (dim 'B') back from the inner PTO Driveline shield (see fig. 2) and make a mark on the outer PTO Driveline.
5. Remove the drivelines from the tractor and implement.
6. Measure from the end of the inner shield to the scribed mark (dim. "C"). Cut the inner shield at that mark. Cut the same amount off the inner shaft (dim. "C1").
7. Measure from the end of the outer shield to the scribed mark (dim. "D"). Cut the outer shield at that mark. Cut the same amount off the inner shaft (dim. "D1").
8. Clean off all burrs from both drivelines.
9. Refer to "Checking PTO Driveline Extended Length" section next.

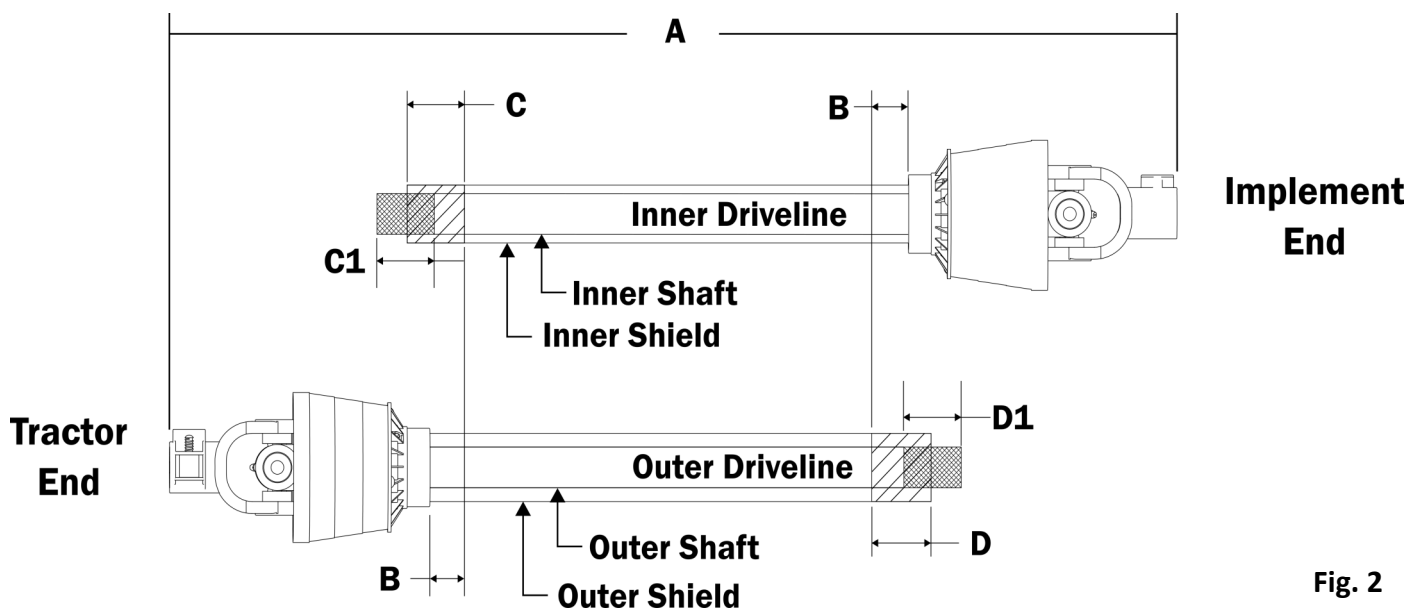

Fig. 2

PTO Driveline Instructions

Checking PTO Driveline Extended Length:

(Refer to Fig. 3)

1. Apply multi-purpose grease to the outside of the inner driveline section. Assemble the outer and inner drivelines.
2. When fully extended, the maximum allowable length must have a minimum overlap of $\frac{1}{3}$ the free length of the inner and outer sections. Measure and record the maximum extended length for future reference.
3. Attach the outer PTO Driveline to the tractor implement input shaft and inner PTO driveline to the implement input shaft.
4. Pull both yoke ends to make sure they are properly seated on the input shafts. **Warning:** If the drive lines are not properly seated, they can separate from the tractor or implement, causing extensive damage and possibly serious injury or death.
5. Raise and lower the implement to determine the maximum extended length. Make sure the maximum extended length does not exceed the maximum length determined from step 2.

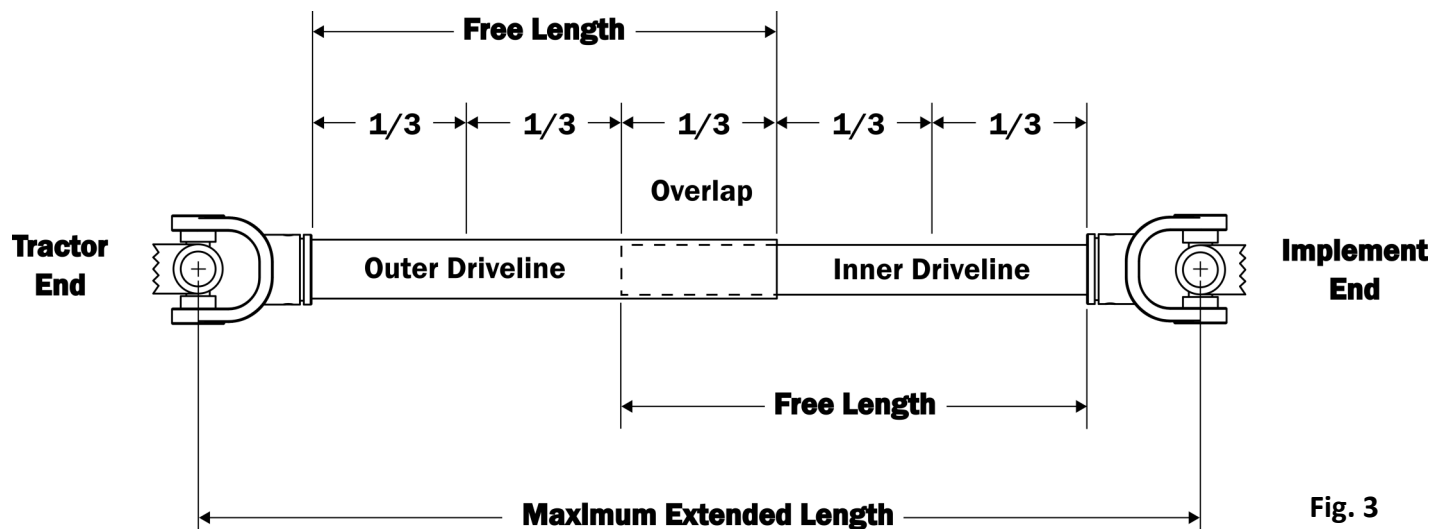

Fig. 3



Danger: Always make sure shields are in place before operating the implement/tractor! Serious injury or death can occur!

Note: Some shields/parts are removed from image for clarity

PTO Driveline Instructions

Checking for PTO Driveline Interference:

(Refer to Fig. 4)

1. Begin with the PTO Driveline level (0 degrees). Raise the implement at an angle no greater than 25 degrees from level. Check for any interference and the length of the PTO Driveline extended. Do not exceed the maximum extended length!
2. Next lower the PTO Driveline at an angle no greater than 25 degrees from level. Check for any interference and the length of the PTO Driveline extended. Do not exceed the maximum extended length!

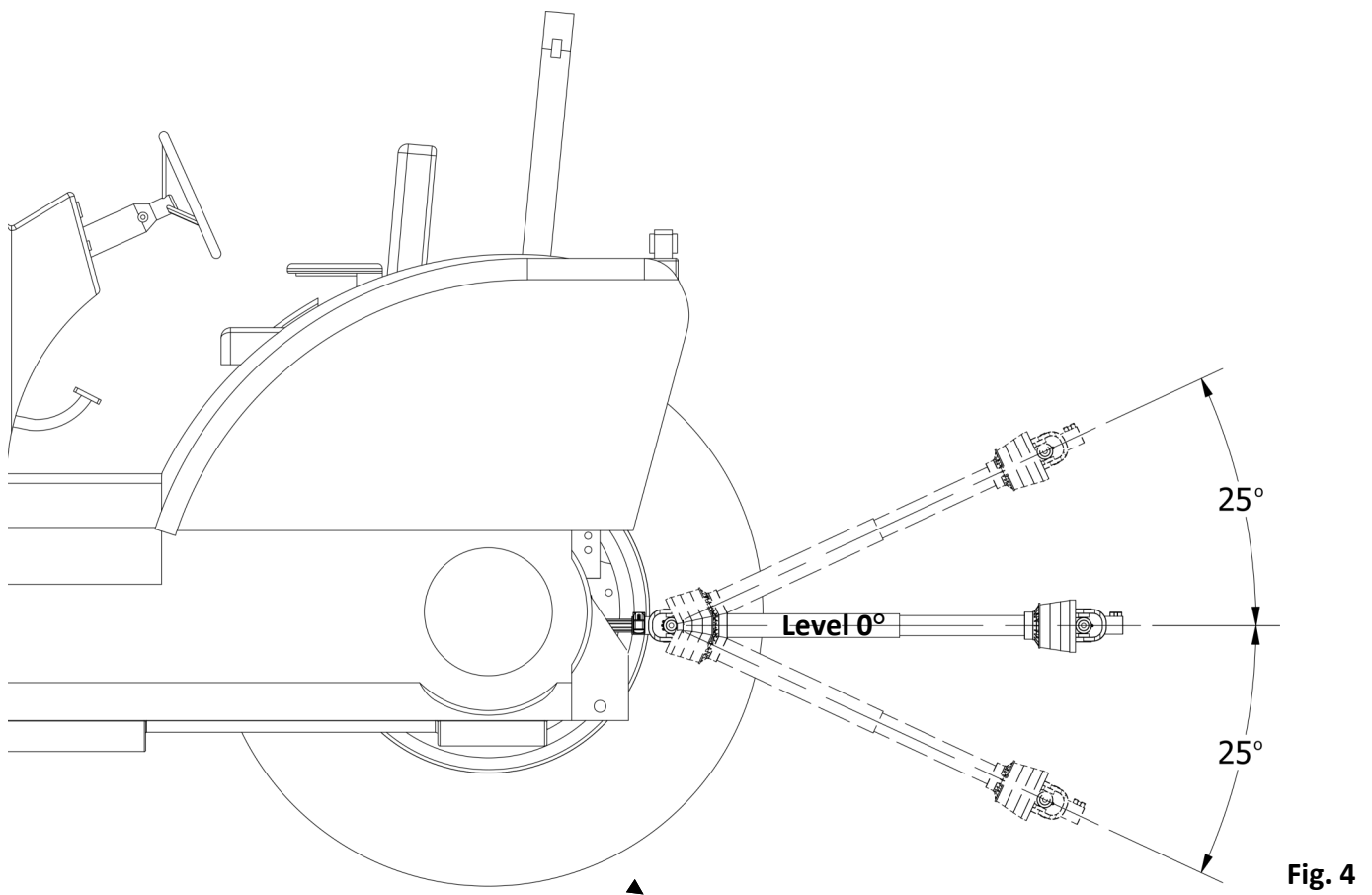

Fig. 4



Danger: Always make sure shields are in place before operating the implement/tractor! Serious injury or death can occur!

Note: Some shields/parts are removed from image for clarity

	⚠ DANGER
	<ul style="list-style-type: none"> • Keep away from rotating driveline. • Keep driveline shields, implement shields, and tractor PTO master shield in place and in good repair. • Operate only with 540 rpm PTO.

Operating Instructions

Cutting Height Adjustment:

The cutting height of the equipment depends on the position of the wheels.

If the wheels are raised, the cutting height increases; if the wheels are lowered, the cutting height decreases.

Make sure that the wheels are set at the same height on both sides.

To adjust the cutting height on the mowers loosen and remove pin **A** and adjust the wheels height according to the bushing **B**. When the adjustment is completed, reinsert the pin **A**.

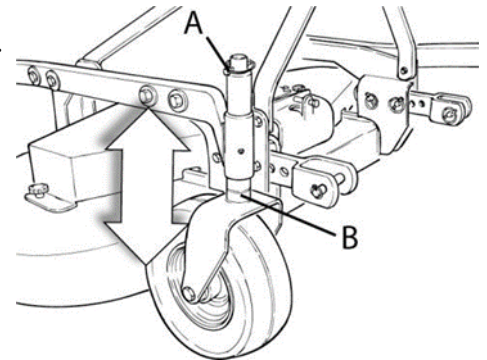

Adjusting Belt Tension:

In the mowers it is necessary to adjust the belt tension as they stretch; the correct belts tensioning ensures that the machine works correctly.

To adjust the belts tension:

Remove the two Belt Shields (A).

Loosen the Nuts (**B**) holding the gearbox in place just enough to allow the gearbox to be able to move. Turn the bolt **C** to adjust the tension of the belts; if you turn the bolt in clockwise direction the belts are tightened, while turning it counter clockwise they are loosened; when the belt is tensioned correctly the belt should be able to deflect a maximum of 10 mm (3/8"). Retighten the Nuts (**B**). Replace Belt Shields (A).

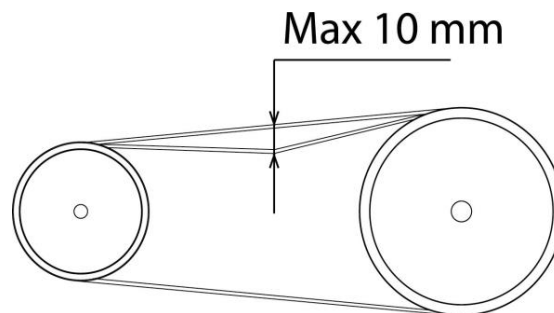
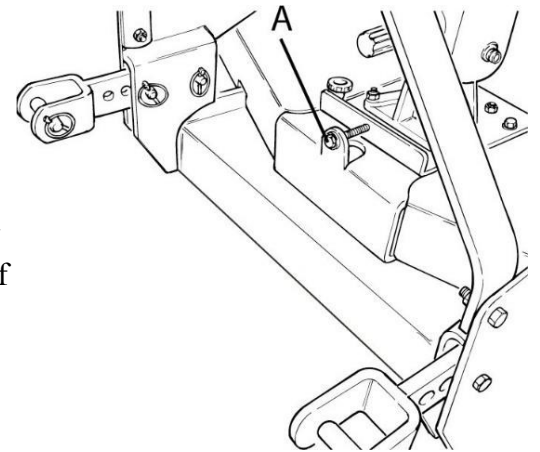

Caution: These activities must be carried out with the engine off, the power take off disengaged and the hand brake applied. If needed, lift the equipment and place it on supports, thus preventing any injuries that might be caused by a sudden fall of the equipment.

Maintenance

Maintenance:

Maintenance is crucial for the working life and efficiency of any agricultural equipment. If the equipment is properly maintained and operated, a long working life and operator safety are assured.

The maintenance intervals indicated in this booklet are provided as a mere reference and are related to normal working conditions; changes may occur depending on the type of activities, environmental dust, seasonal factors, etc.

First check

After 50 working hours, check the oil in the gearbox (A) and make sure that all the screws and bolts are tightened.

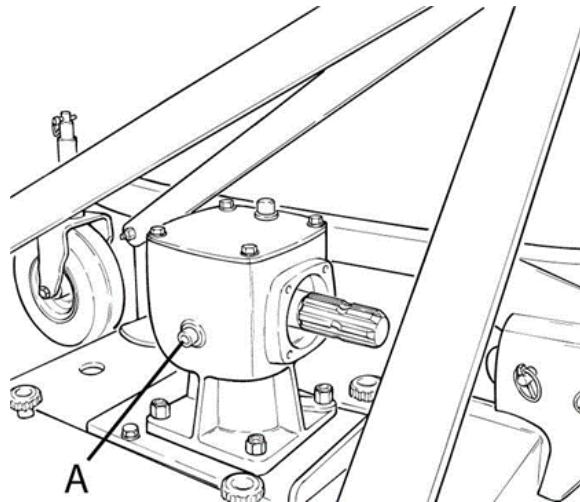

Caution: Before injecting lubricating grease into the grease fittings, clean the fittings to prevent mud, dust, or any other foreign matter from contaminating the grease and reducing the lubrication effect.

When adding or changing the oil, use the same type of oil to prevent mixing oils with different features.

All maintenance activities must be carried out with the mower resting horizontally on the ground, with the equipment off and not overheated.

After using the equipment for a few hours, make sure that all the bolts are tightened;

Maintenance

Every 20 working hours

Lubricate the pulley support bearing (C).

Every 30 working hours

Check belt tensioning.

Every 40 working hours

Lubricate the wheel supports (A).

After the first 50 working hours and, later, every 800 working hours

Replace the oil in the gearbox. Use SAE EP 80W90.

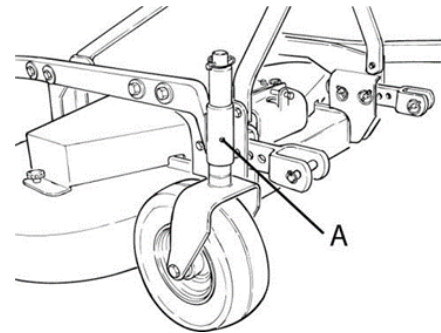
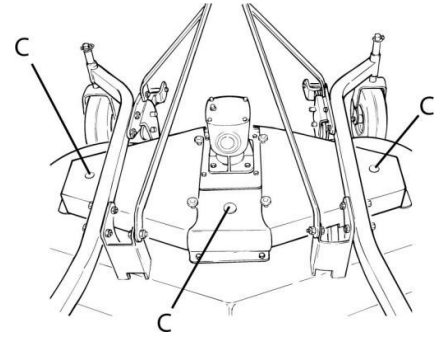

BLADE REPLACEMENT

For optimal results, check the mower blades frequently, especially if cutting in sandy or rocky soil. Dull, worn blades will cut grass uneven and streak.

Take any and all measures to prevent accidental machine start-up.

Place the equipment on sturdy supports.

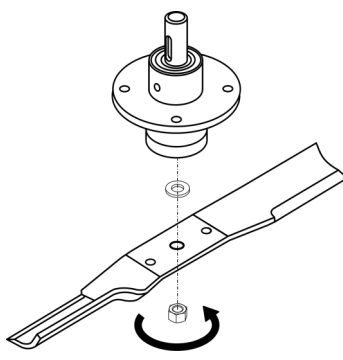
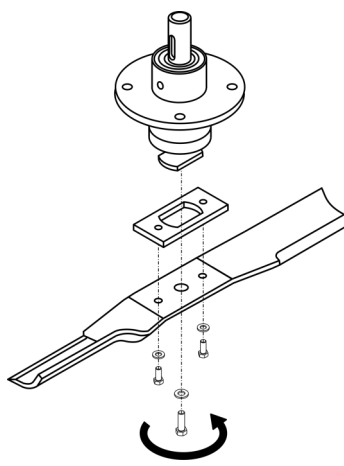
Version 1: Blade w/ Center Nut	Version 2: Blade w/ Center Bolt
<p>Remove the lock nut by turning the center nut counter clockwise. Replace with new OEM blade and hardware. Inspect the condition of the spindle at this time. Replace if necessary.</p> 	<p>Remove the center bolt by turning the center bolt counter clockwise. Next remove the blade adaptor plate hardware. Replace with new OEM blade and hardware. Inspect the condition of the spindle at this time. Replace if necessary.</p> 



Danger: Before replacing the blades, turn the tractor engine off, pull the parking brake, disengage the power take off, raise the mower using the tractor lift, and install supports to prevent accidental dropping of the machine.

Trouble Shooting

Problem	Possible Cause	Solution
Streaking	Slow blade tip speed	Operate PTO at 540 RPM
	Worn blade tips	Replace with new OEM blades
	Dull blades	Sharpen, balance old blades or replace with new OEM blades
	Blades unable to cut the part of grass pressed down by tractor's tire path or mower's casters	Slow tractor's ground speed but maintain 540 RPM PTO speed
	Ground speed too fast	Shift tractor to a lower gear
	Drive belt loose	Tighten per instructions on page 16
	Blade loose on spindle	Tighten blade nut to proper specs, page 18
	Conditions too wet for mowing	Allow grass to dry before mowing
Grass discharges from mower unevenly or bunches along a swath	Material too high and too thick	Slow tractor's ground speed but maintain 540 RPM PTO speed. Make two passes. Raise the mower for the first pass and lower to the desired cutting height for the second and cut at 90 degrees to the first pass. Cut a partial swath only.
	Belt slipping	Tighten belt or replace with correct specified belt.
	Grass wet	Allow grass to dry before mowing. Slow tractor's ground speed but maintain 540 RPM PTO speed.
Excessive vibration	Driveline broken or bent	Replace with OEM driveline
	Broken/bent blade	Replace with OEM blade
	Worn/unbalanced blade	Sharpen, balance or replace with OEM blade
	Bent/broken sheave	Replace with correct specified part
	Debris caught on blade	Clean blade, spindle, inspect blade and replace with OEM blade if necessary
Belt slipping	Belt loose	Tighten or replace with OEM belt
	Belt glazed	Use belt dressing or replace with OEM belt
	Mower is overloading, grass is too tall or heavy	Slow tractor's ground speed but maintain 540 RPM PTO speed. Make two passes. Raise the mower for the first pass and lower to the desired cutting height for the second and cut at 90 degrees to the first pass. Cut a partial swath only.
	Oil on belt from over lubrication	Clean lubricant from belt and sheaves with a clean rag, Replace oil soaked belts. Be sure to
	Belt hung or rubbing	Check belt for free travel in pulleys. Check under mower deck and spindles for debris or other foreign material and remove if any is present.

Torque Specifications for Common Bolt Sizes															
Inches		Bolt Head Identification						Metric		Bolt Head Identification					
										5.8		8.8		10.9	
Bolt size (inches)	Thread pitch	Grade 2		Grade 5		Grade 8		Class 5.8		Class 8.8		Class 10.9			
		N.m	ft-lb	N.m	ft-lb	N.m	ft-lb	N.m	ft-lb	N.m	ft-lb	N.m	ft-lb		
1/4"	20	7	5	11	8	16	12	M5	0.08	4	3	6	4	9	7
1/4"	28	8	6	13	10	19	14	M6	1	6	4	10	7	15	11
5/16"	18	15	11	24	17	33	25	M8	1.25	16	12	25	18	36	27
5/16"	24	17	13	26	19	37	27	M8	1	17	13	26	19	38	28
3/8"	16	27	20	42	31	59	44	M10	1.5	31	23	48	35	71	52
3/8"	24	31	23	47	35	67	49	M10	1.25	33	24	51	38	75	55
7/16"	14	43	32	67	49	95	70	M10	1	35	26	53	39	78	58
7/16"	20	48	36	75	55	106	78	M12	1.75	54	40	84	62	123	91
1/2"	13	66	48	102	75	144	106	M12	1.5	56	41	87	64	128	94
1/2"	20	75	55	115	85	163	120	M12	1.25	59	44	90	66	133	98
9/16"	12	95	70	147	109	208	154	M14	2	84	62	133	98	195	144
9/16"	18	106	79	164	121	232	171	M14	1.5	94	69	142	105	209	154
5/8"	11	132	97	203	150	287	212	M16	2	131	97	206	152	302	223
5/8"	18	149	110	230	170	325	240	M16	1.5	141	104	218	161	320	236
3/4"	10	233	172	361	266	509	376	M18	2.5	181	133	295	218	421	310
3/4"	16	261	192	403	297	569	420	M18	2	196	145	311	229	443	327
7/8"	9	226	167	582	430	822	606	M18	1.5	203	150	327	241	465	343
7/8"	14	249	184	642	473	906	668	M20	2.5	256	189	415	306	592	437
1"	8	339	250	873	644	1232	909	M20	1.5	288	212	454	335	646	476
1"	12	371	273	955	704	1348	995	M22	2.5	344	254	567	418	807	595
1-1/8"	7	480	354	1077	794	1746	1288	M22	1.5	381	281	613	452	873	644
1-1/8"	12	539	397	1208	891	1958	1445	M24	3	444	327	714	526	1017	750
1-1/4"	7	677	500	1519	1120	2463	1817	M24	2	488	360	769	567	1095	808
1-1/4"	12	750	553	1682	1241	2728	2012	M27	3	656	484	1050	774	1496	1103
1-3/8"	6	888	655	1992	1469	3230	2382	M27	2	719	530	1119	825	1594	1176
1-3/8"	12	1011	746	2268	1673	3677	2712	M30	3.5	906	668	1420	1047	2033	1499
1-1/2"	6	1179	869	2643	1949	4286	3161	M30	2	1000	738	1600	1180	2250	1659
1-1/2"	12	1326	978	2974	2194	4823	3557	M36	4	1534	1131	2482	1830	3535	2607

Notes:

This chart is an approximate estimate of torque values.

Always tighten hardware to these values unless a different torque value or tightening procedure is listed for a specific application.

Fasteners must always be replaced with the same grade as specified in the manual.

Always use the proper tool for tightening hardware: SAE for SAE hardware and Metric for Metric hardware.

Make sure that fastener threads are clean and that you properly start thread engagement.

Page left blank intentionally

Page left blank intentionally



Rear Discharge Finishing Mower

BFM-100 Series

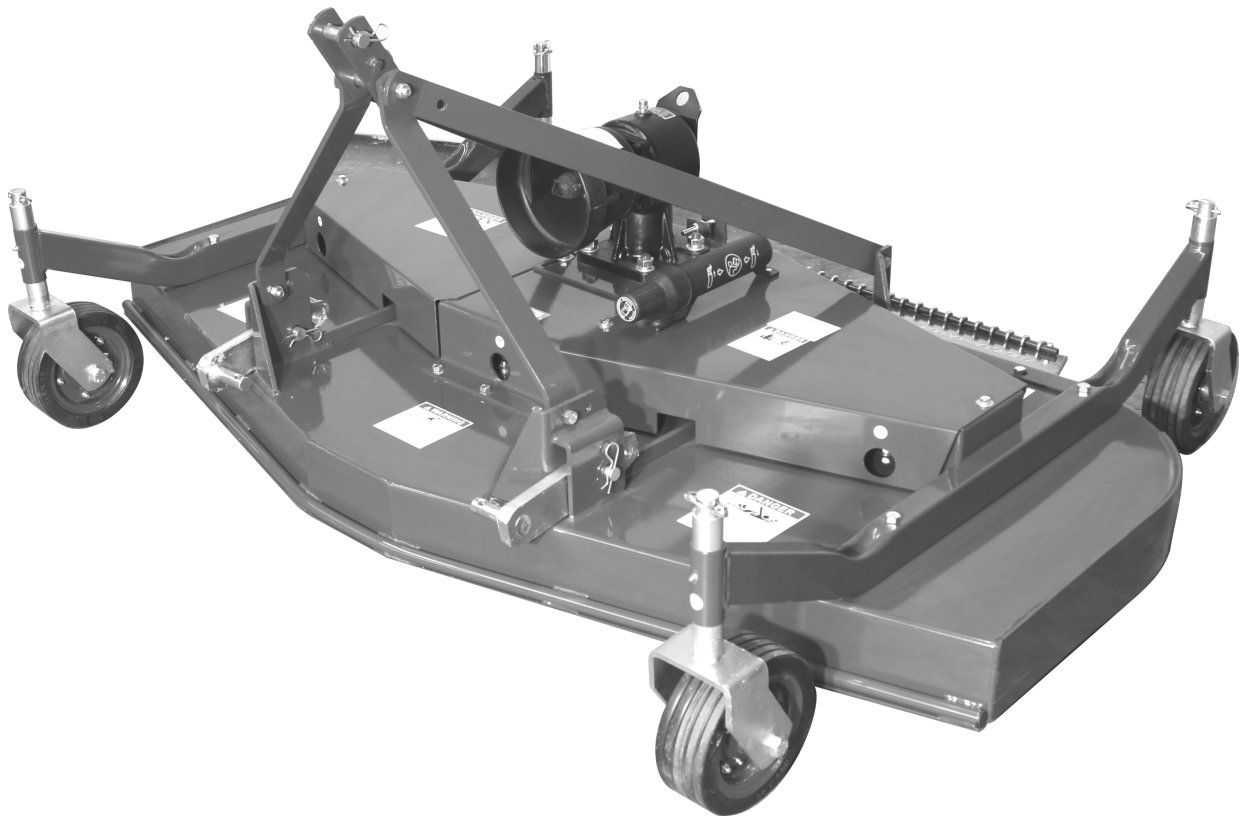

Parts Manual

Rev. 02/26

Mower Assembly BFM105 & BFM106

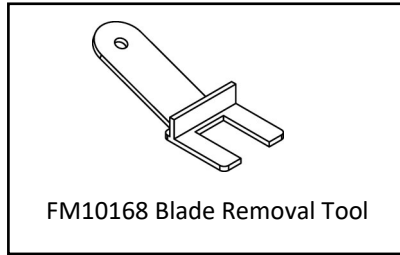
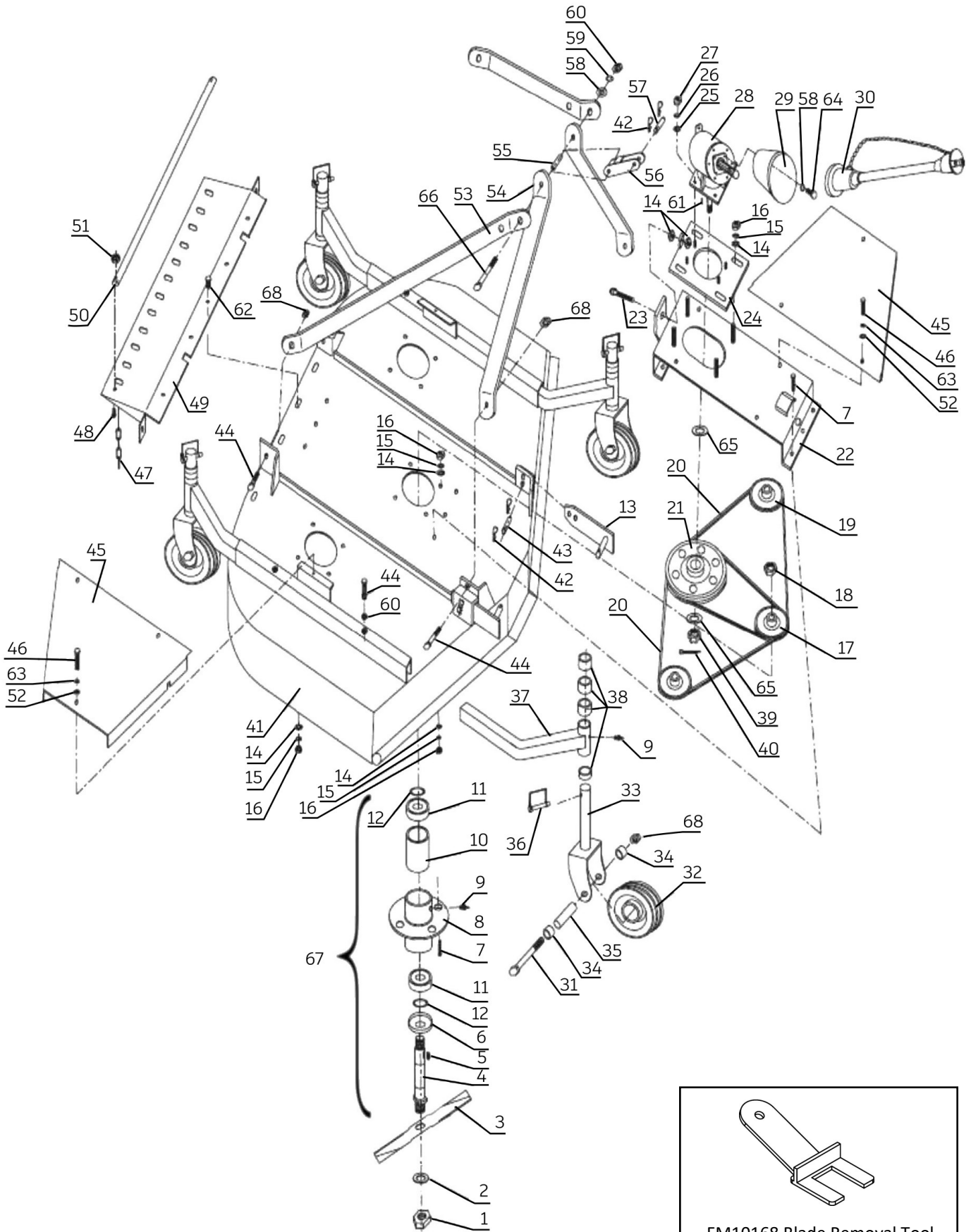

Mower Assembly BFM105 & BFM106

Item	Part #	Description	Qty.
1	LNM1815	Nut locking M18-1.5	3
2	LFW18	Washer large fender M18	3
3	FMB4002	Blade 5' 505 x 50 x 6	3
	FMB4003	Blade 6' 610 x 60 x 6	3
4	FM10038	Blade spindle shaft	3
5	KM080730	Key - M8 x 7 x 30	3
6	FM10040	Dust cap	3
7	BM101530	Bolt HH M10-1.5x30	17
8	FM10041	Spindle housing	3
9	GN081S	Grease nipple - M8x1.0 (straight)	7
10	FM10043	Steel sleeve	3
11	B62052RS	Bearing B62052 2RS	6
12	FM10112	Spacer washer	7
13	FM10044	Joint plate, BFM-105	2
	FM10045	Joint plate 6'	2
14	FW10	Washer flat M10, BFM-105	28
	FW10	Washer flat M10, BFM-106	29
15	LW10	Washer lock M10, BFM-105	28
	LW10	Washer lock M10, BFM-106	29
16	NM1015	Nut HH M10-1.5, BFM-105	28
	NM1015	Nut HH M10-1.5, BFM-106	29
17	FM10046	Double pulley, BFM-105	1
	FM10047	Double pulley, BFM-106	1
18	TNM2415	Nut, thin HH M24-1.5	3
19	FM10048	Single pulley, BFM-105	2
	FM10049	Single pulley, BFM-106	2
20	FM10051	V-belt B1575L, BFM-105	2
	FM10052	V-belt B1880, BFM-106	2
21	FM10054	Main input pulley	1
22	FM10056	Gearbox rest	1
23	BM101585FT	Bolt HH M10-1.5x85 8.8 zinc (full thread)	1
24	FM10057	Sliding plate	1
25	FW16	Washer flat M16	4
26	LW16	Washer lock M16	4
27	NM16	Nut HH M16-2.0	?
28	FM10058	Gearbox	1
29	FM10060	Safety guard	1
30	FM10062	PTO complete, BFM-105	1
	FM10063	PTO complete, BFM-106	1
31	BM1620140	Bolt HH M16-20x140 8.8 zinc	4
32	FM10102	Wheel 210 x 80	4
33	FM10067	Wheel yoke	4
34	FM10108	Wheel spacer set (sold in sets of 2)	4
35	FM10066	Wheel axle sleeve	4
36	DLYNPN08	D shape lynch pin M8	4
37	FM10071	Formed wheel arm 5'	2
	FM10070	Formed wheel arm 6'	2

Mower Assembly BFM105 & BFM106

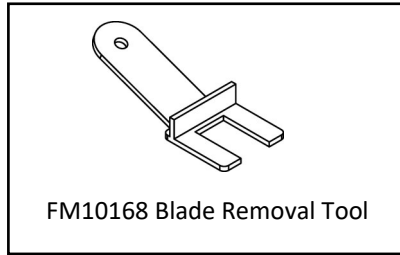
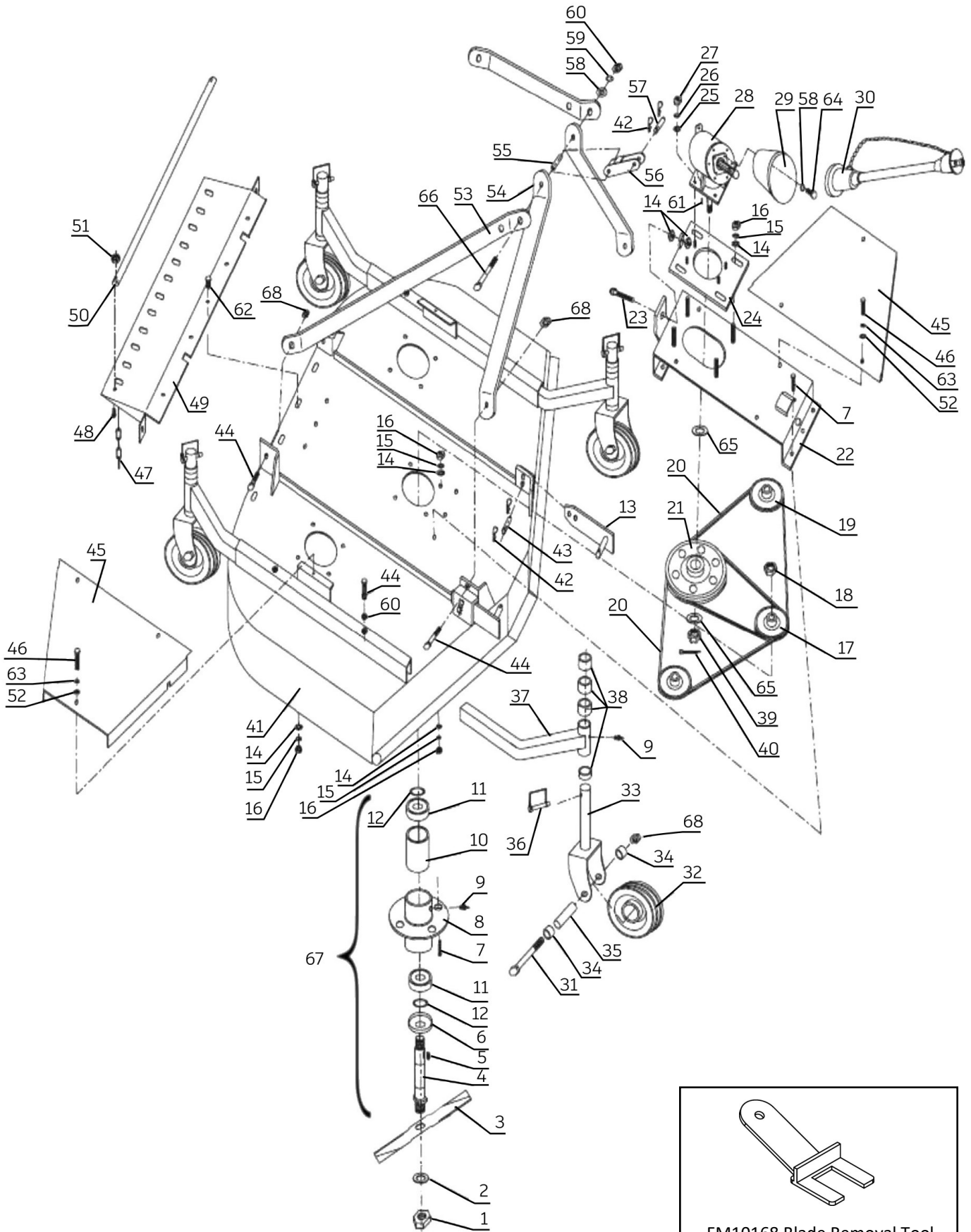

Mower Assembly BFM105 & BFM106

Item	Part #	Description	Qty.
38	FM10073	Height control spacer 1/4"	4
	FM10074	Height control spacer 1/2"	4
	FM10075	Height control spacer 3/4" (optional)	4
	FM10103	Height control spacer 1"	4
	FM10105	Height control spacer 1-1/2"	4
39	CNM242	Castle nut M24-2.0	1
40	CP5x50	Cotter pin 5x50	1
41	FM10077	Main deck, BFM-105	1
	FM10078	Main deck, BFM-106	1
42	FM10079	Hair pin	6
43	FM10080	Pin M19x60.5	2
44	BM1217540	Bolt HH M12-1.75x40 8.8 zinc	8
45	FM10082L	Belt guard, BFM-105, LH	1
	FM10082R	Belt guard, BFM-105, RH	1
	FM10083L	Belt guard, BFM-106, LH	1
	FM10083R	Belt guard, BFM-106, RH	1
46	BM0812515	Bolt HH M8-1.25x15 8.8 zinc	6
47	FM10085	Chain, BFM-105	24
	FM10086	Chain, BFM-106	35
48	BM061025	Bolt HH M6-1.0x25 8.8 zinc	2
49	FM10088	Deflector, BFM-105	1
	FM10089	Deflector, BFM-106	1
50	FM10091	Chain rod, BFM-105	1
	FM10092	Chain rod, BFM-106	1
51	LNLM061	Nut locking M6-1.0	2
52	FW08	Washer flat M8	6
53	FM10094	Rear brace, BFM-105	2
	FM10095	Rear brace, BFM-106	2
54	FM10096	Front brace	2
55	FM10097	Brace (spacer)	1
56	FM10098	Upper hitch	1
57	FM10099	Pin M19.5x85	1
58	FW12	Washer M12	1
59	LW12	Washer lock M12	1
60	NM12175	Nut HH M12-1.75	1
61	KM100835	Key M10 x 8 x 35	1
62	BM101525	Bolt HH M10-1.5x25 8.8 zinc, BFM-105	7
	FW10	Washer flat M10	14
	LW10	Washer lock M10	7
	NM1015	Nut HH M10-1.5	7
-	BM101525	Bolt HH M10-1.5x25 8.8 zinc, BFM-106	8
	FW10	Washer flat M10	16
	LW10	Washer lock M10	8
	NM1015	Nut HH M10-1.5	8
63	LW08	Washer lock M8	6
64	BM0812512	Bolt HH M8-1.25x12 8.8 zinc	4
65	FW24	Washer flat M24	4
66	BM12175130	Bolt HH M12-1.75x130 8.8 zinc	1
67	FM10101	Blade spindle complete	1
68	LNLM1620	Nut HH M16-2.0	4

Mower Assembly BFM-107

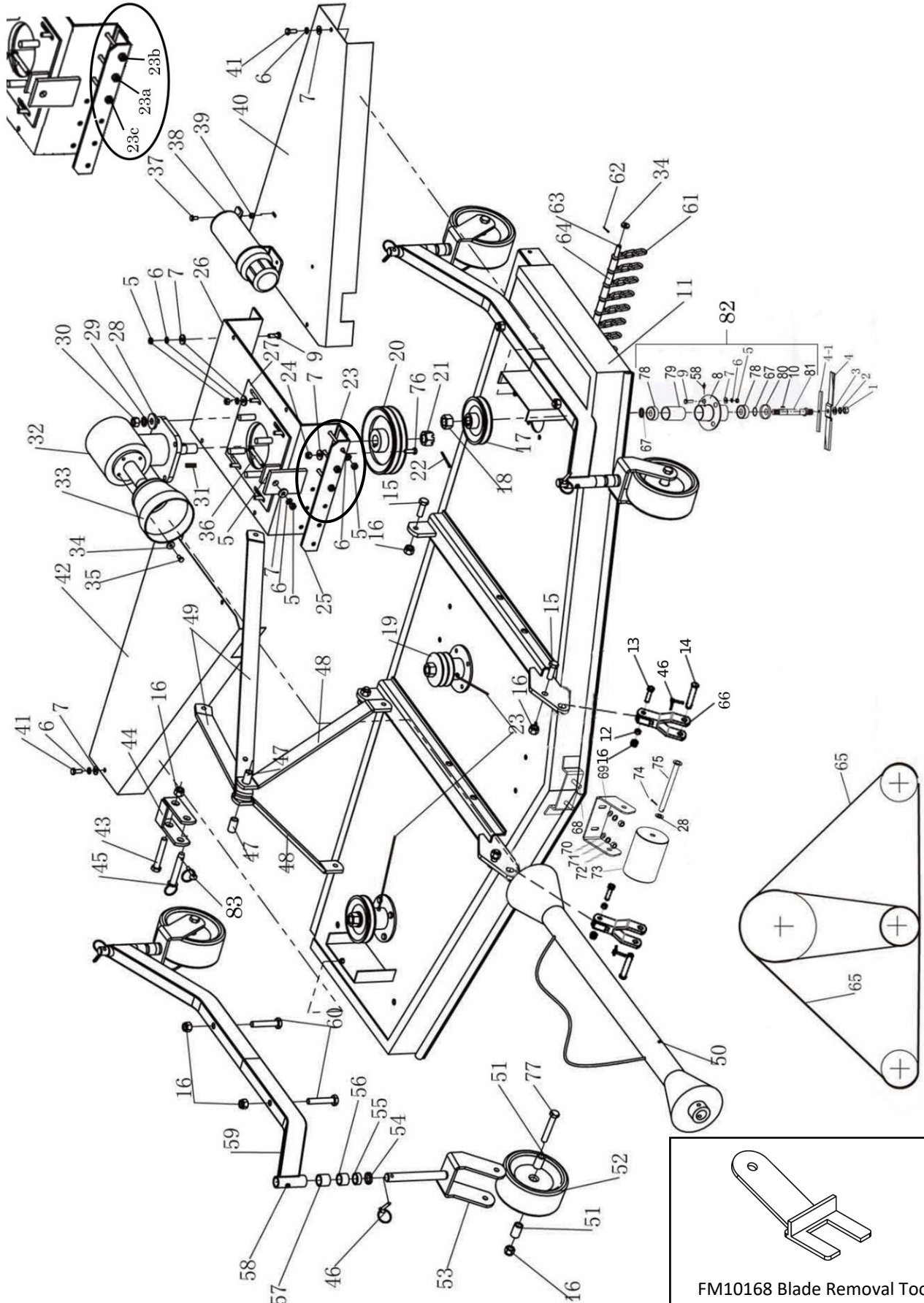

Mower Assembly BFM-107

Item	Part #	Description	Qty.
1	NM1815	Nut HH M18-1.5	3
2	LW18	Washer lock M18	3
3	FW18	Washer flat M18	3
4	FM60004	Blade 710x60x6	3
4-1	FM10129	Blade guard	3
5	NM1015	Nut HH M10-1.5	24
6	LW10	Washer lock M10	22
7	FW10	Washer flat M10	22
8	FM10130	Bearing holder	3
9	BM101530	Bolt HH M10-1.5x30	15
10	KM080730	Round end key 8x7x30	3
11	FM10131	Main deck BFM-107	1
12	FM10132	Spacer Ø22x2.5x11.5	2
13	BM162060	Bolt HH M16-2.0x60	2
14	FM10164	Hitch pin Ø22x120	2
15	BM162045	Bolt HH M16-2.0x45	4
16	LNM1620	Nut locking M16-2.0	15
17	FM10049	Single belt pulley	2
18	TNM2415	Nut, thin HH M24-1.5	3
19	FM10047	Two grove v-belt pulley	1
20	FM10054	Double belt pulley	1
21	CNM242	Nut castle M24-2.0	1
22	CP5x50	Cotter pin M5x50	1
23a	FM10133	Oil filling pipe for spindle - L 250mm (middle)	1
23b	FM10162	Oil filling pipe for spindle - L 750mm (LH)	1
23c	FM10163	Oil filling pipe for spindle - L 850mm (RH)	1
24	LNM1015	Nut locking M10-1.5	3
25	FM10134	Mounting plate grease nipples	1
26	FM10135	Gearbox rest	1
27	FM10136	Sliding plate gear box	1
28	FW16	Washer flat M16	5
29	LW16	Washer lock M16	4
30	NM1620	Nut HH M16	4
31	KM100840	Round end key 10x8x40	1
32	FM10058	Gearbox	1
33	FM10060	Safety guard	1
34	FW08	Washer flat M08	10
35	BM0812512	Bolt HH M08-1.25x12	4
36	BM1015100	Bolt HH M10-1.5x100	1
37	BM0812520	Bolt HH M08-1.25x20	2
38	MH20000	Manual holder small	1
39	LNM08125	Nut locking M08-1.25	2

Mower Assembly BFM-107

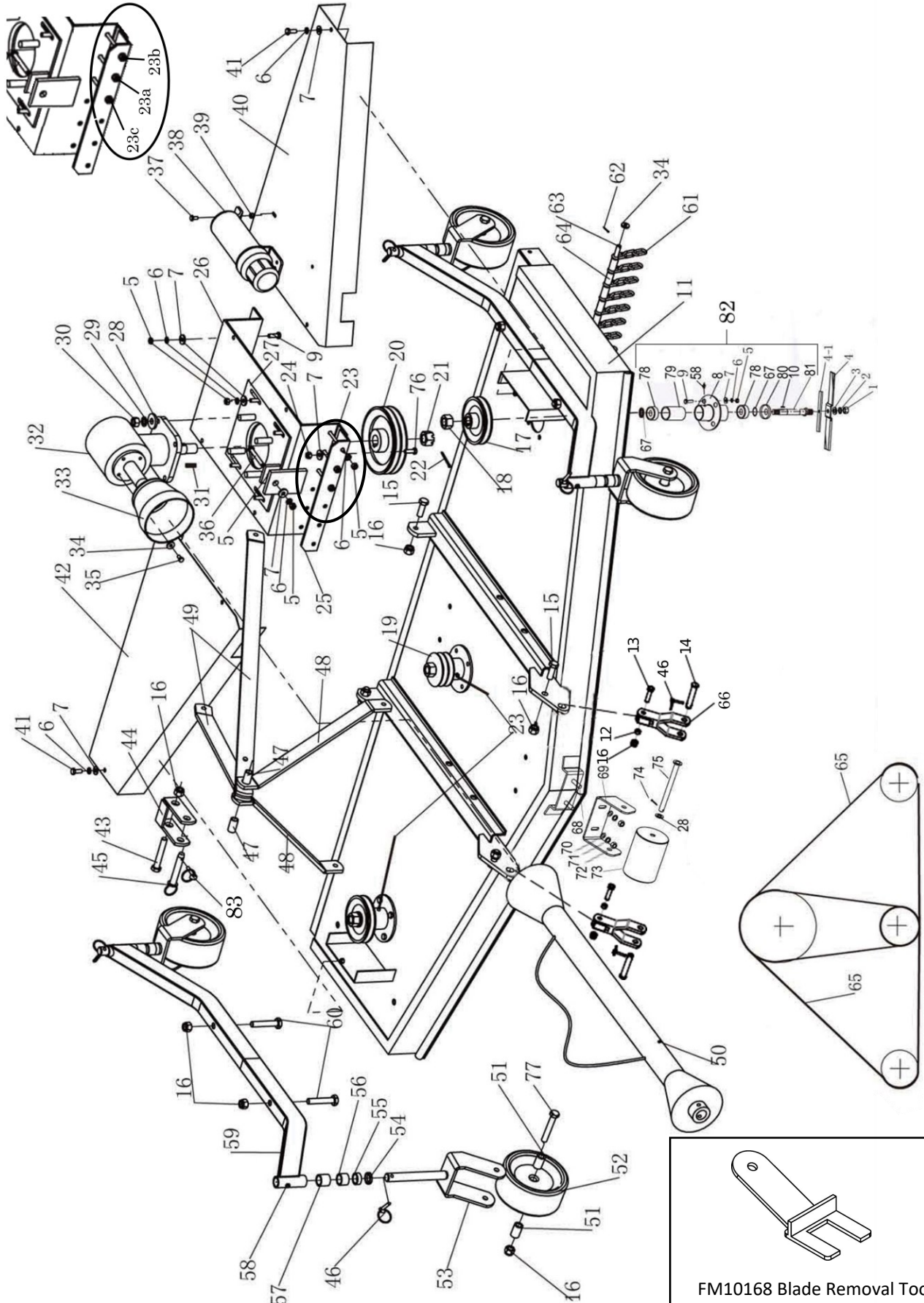

Mower Assembly BFM-107

Item	Part #	Description	Qty.
40	FM10137	RH belt guard	1
41	BM0812515	Bolt HH M08-1.25x15	6
42	FM10138	LH belt guard	1
43	BM1620100	Bolt HH M16-2.0x100	1
44	FM10139	Upper hitch	1
45	FM10140	Pin	1
46	DLYNPN08	D shape lynch pin M8	4
47	FM10141	Upper bushing 25x4x16	2
48	FM10142	Front brace	2
49	FM10143	Rear brace	2
50	FM10063	PTO shaft	1
51	FM10144	Bushing for wheel axle	8
52	FM10102	Wheel	4
53	FM10145	Wheel fork	4
54	FM10073	Wheel spacer M6	4
55	FM10074	Wheel spacer M12	4
56	FM10103	Wheel spacer M24	4
57	FM10146	Wheel spacer M30	4
58	GN081S	Grease nipple M8-1.0	7
59	FM10147	Wheel arm	2
60	BM162085	Bolt HH M16-2.0x85	4
61	FM10148	Chain M6x3 links	65
62	CP2.5x25	Cotter pin M2.5x25	2
63	FM10150	Chain rod M8	1
64	FM10151	Spacer sleeve	63
65	FM60065	V-belt VB2134	2
66	FM10161	Hitch block	2
67	FM10112	Spacer washer	6
68	BM1217535	Bolt HH M12-1.75x35	2
69	FM10153	Roller mounting bracket	1
70	FW12	Washer flat M12	2
71	LW12	Washer lock M12	2
72	NM12175	Nut HH M12-175	2
73	FM10154	Roller	1
74	CP4x40	Cotter pin M4x40	1
75	FM10156	Roller mounting pin	1
76	BM101535	Bolt HH M10-1.5x35	3
77	BM1620110	Bolt HH M16-2.0x110	4
78	B6205-2RS	Bearing 6205	6
79	FM10157	Spacer	3
80	FM10158	Dust cap	3
81	FM10159	Spindle shaft	3
82	FM70101	Blade spindle complete, BFM-107	3
83	LYNPN08	Lynch pin M8	1

Decals

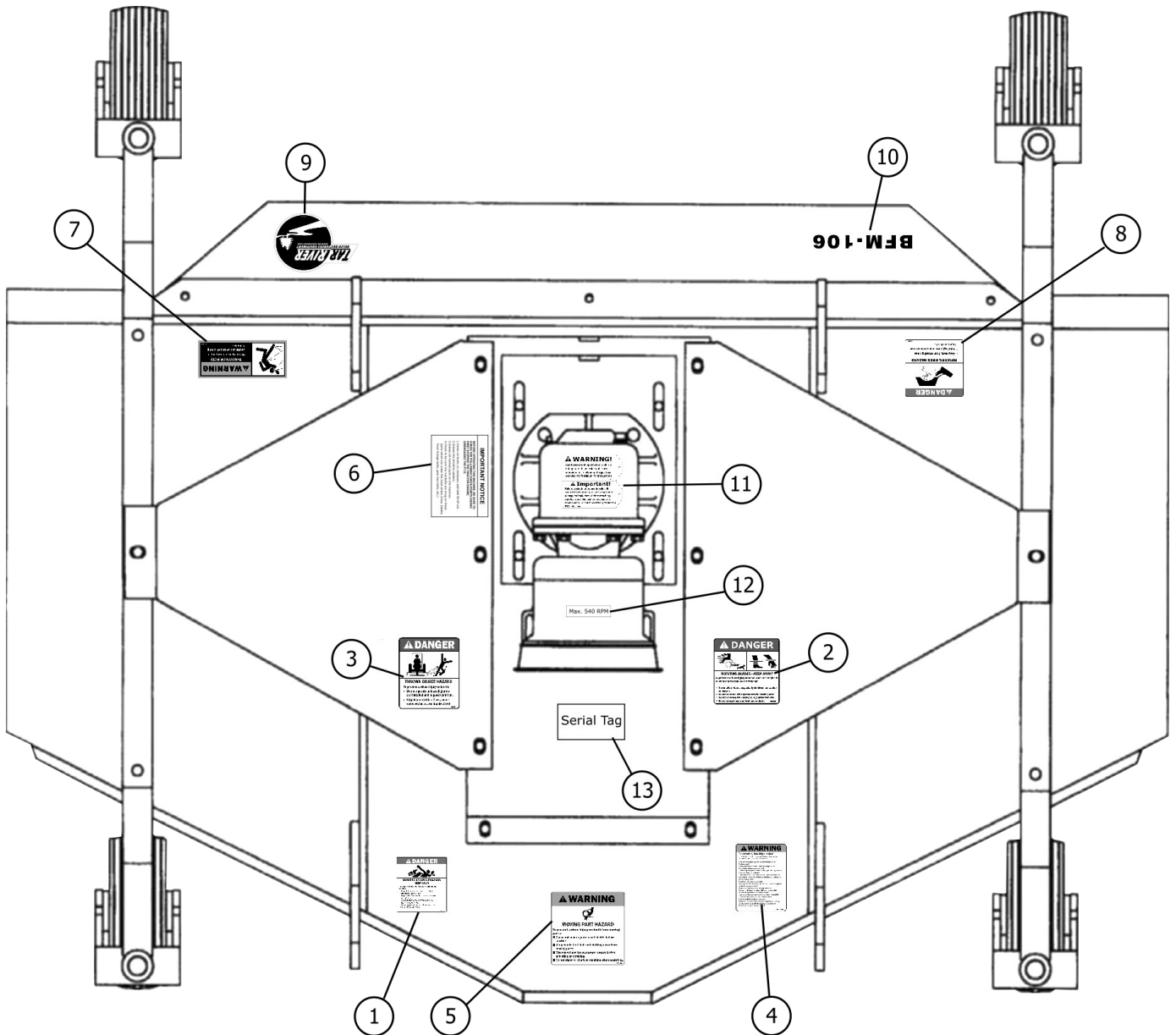

Decals

Item	Part #	Description	Qty.
1	RT1007	Decal Danger Rotating Driveline	1
2	M400	Decal Danger Rotating Blades	1
3	M600	Decal Danger Thrown Objects	1
4	RT1004D	Decal Warning To Prevent Injury	1
5	D1314	Decal Warning Moving Part Hazard	1
6	NA	Decal Important Notice	1
7	D1003	Decal Warning Thrown Object	1
8	RT1006	Decal Danger Rotating Tines	1
9	RT1016	Decal Logo Tar River	1
10	NA	Decal Model # BFM-105	1
	NA	Decal Model # BFM-106	1
	NA	Decal Model # BFM-107	1
11	T1001-T1002	Tag Check Oil	1
12	NA	Decal Max. RPM 540	1
13	NA	Serial Tag	1

Warranty

LIMITED WARRANTY

Belco Resources Equipment warrants to the original purchaser of any new piece of machinery from Belco Resources Equipment, purchased from an authorized Belco Resources Equipment dealer, that the equipment be free from defects in material and workmanship for a period of one (1) year for non-commercial, state, and municipalities' use, ninety (90) days for commercial use from date of retail sale. Warranty for rental purposes is thirty (30) days. The obligation of Belco Resources Equipment to the purchaser under this warranty is limited to the repair or replacement of defective parts.

Replacement or repair parts installed in the equipment covered by this limited warranty are warranted for ninety (90) days from the date of purchase of such part or to the expiration of the applicable new equipment warranty period, whichever occurs later. Warranted parts shall be provided at no cost to the user at an authorized Belco Resources Equipment dealer during regular working hours. Belco Resources Equipment reserves the right to inspect any equipment or parts, which are claimed to have been defective in material or workmanship.

This limited warranty does not apply to and excludes wear items such as shear pins, tires, tubes knives, blades or other wear items. Oil or grease is not covered by this warranty.

All obligations of Belco Resources Equipment under this limited warranty shall be terminated if:

- Proper service is not performed on the machine.

- The machine is modified or altered in any way.

- The machine is being used or has been used for purposes other than those for which the machine was intended.

DISCLAIMER OF IMPLIED WARRANTIES & CONSEQUENTIAL DAMAGES

Belco Resources Equipment obligation under this limited warranty, to the extent allowed by law, is in lieu of all warranties, implied or expressed, including implied warranties of merchantability and fitness for a particular purpose and any liability for incidental and consequential damages with respect to the sale or use of the items warranted. Such incidental and consequential damages shall include but not be limited to: transportation charges other than normal freight charges; cost of installation other than cost approved by Belco Resources Equipment; duty; taxes; charges for normal service or adjustment; loss of crops or any other loss of income; rental of substitute equipment, expenses due to loss, damage, detention or delay in the delivery.

REGISTRATION

The online Warranty Registration must be completed in order to qualify for coverage on this Limited Warranty. Visit br-equipment.com, click on "Warranty Registration" and completely fill out the form to register the new piece of equipment.

Page left blank intentionally



401 Jeffreys Road
Rocky Mount, NC 27804
www.tarrivermfg.com

Tel: 252-822-7140
Fax: 252-787-5855
Sales@tarrivermfg.com